

Garage-in-a-Box SUV/Truck[®]

4,0 x 6,1 x 3,7 m

#62711

TILLFÄLLIG KONSTRUKTION

 = Nyttig information

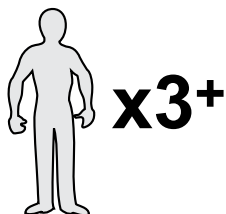
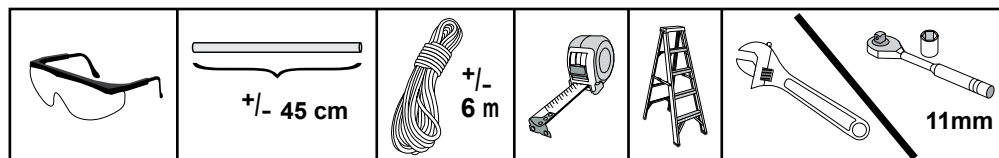
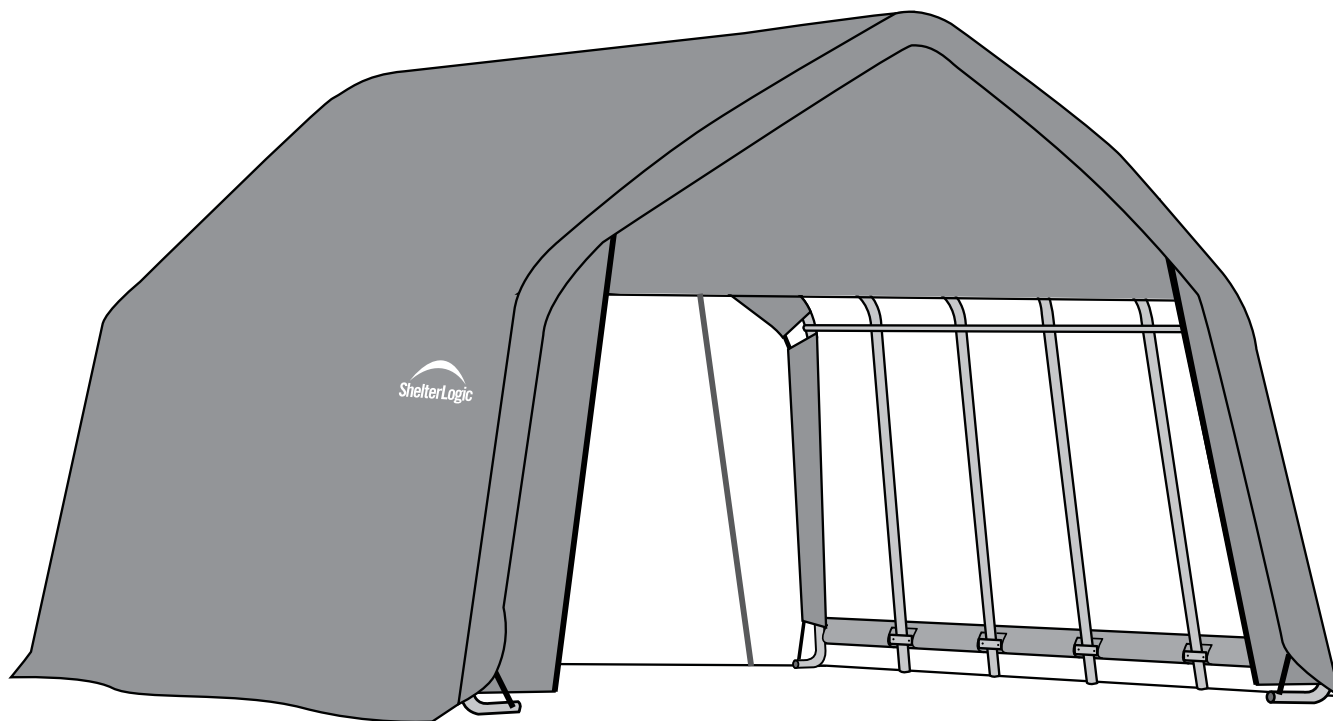



OBSERVERA:

Detta skydd är tillverkat av kvalitetsmaterial. Det är designat för att passa det skräddarsydda tygöverdraget från ShelterLogic®, Corp. som ingår. Skydd från ShelterLogic®, Corp. erbjuder förvaring och skydd från skador som orsakas av sol, lätt regn, träsav, djur- och fågelspillning och lätt snö. Förankra denna konstruktion från ShelterLogic®, Corp. ordentligt. Läs anvisningen för mer detaljerad information om förankringen. Det är kundens ansvar att förankra ordentligt, hålla skyddet spänt och fritt från snö och skräp. Läs och förstå monteringsanvisningen, varningarna och försiktighetsåtgärderna innan monteringen påbörjas. Ring kundtjänst på numret nedan om du har några frågor. Hänvisa till garantikortet i förpackningen.

FARA:

Kontrollera alla lokala bestämmelser för installation av tillfälliga skydd innan monteringen påbörjas. Välj platsen för ditt skydd omsorgsfullt. Fara: Håll borta från elledningar. Kontrollera luftdragna ledningar, trädgrenar eller andra föremål. Kontrollera nedgrävda rör och ledningar innan du gräver. Montera INTE nära tak eller andra konstruktioner varifrån snö, is eller överdriven avrinning kan hamna på ditt skydd. Häng INTE föremål från taket eller i stödvajrarna.



VARNING:

Brandrisk. Rök inte eller använd inte anordningar med öppen eld (däribland grillar, eldstäder, fritöser, rökkanor eller lyktor) i eller i närheten av skyddet. Förvara INTE lättantändliga vätskor (bensin, fotogen, propan osv.) i eller i närheten av ditt skydd. Utsätt inte taket eller sidorna på skyddet för öppen eld eller annan flammkälla.

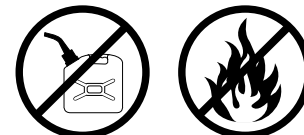

FÖRSIKTIGHETSÅTGÄRDER:

Var FÖRSIKTIG när du reser ramen. Använd skyddsglasögon under monteringen. Säkra och fäst stolpar som är placerade över huvudet med bultar under monteringen. Se upp för stolpkanterna.

ORDENTLIG FÖRANKRING OCH MONTERING AV RAMEN:

DET ÄR KUNDENS ANSVAR ATT FÖRANKRA RAMEN ORDENTLIGT.

ShelterLogic®, Corp. ansvarar inte för skador på enheten eller innehållet som orsakats av naturkrafter. Skydd som inte är säkert förankrade kan flyga iväg och orsaka skada. Detta täcks inte av garantin. Kontrollera förankringarna emellanåt för att säkerställa att skyddet är stabilt. ShelterLogic®, Corp. kan inte hållas ansvarig för skydd som blåser iväg. OBSERVERA: Överdraget till ditt skydd kan snabbt tas bort och förvaras i händelse av svåra väderförhållanden. Om väderprognoserna förutspår stark vind eller oväder i ditt område rekommenderar vi att du tar bort överdraget.

RESERVDELAR, MONTERING, SPECIALBESTÄLLNINGAR:

Originalreservdelar och -tillbehör från ShelterLogic®, Corp. kan levereras från fabriken, däribland förankringsseter för nästan alla användningsområden, ersättningsöverdrag, vägg- och inhägnadssatser, ventilations- och belysningsseter, ramdelar, blyxtläsförsedda dörrar och andra tillbehör. Alla artiklar skickas från fabriken direkt till din dörr.

SKÖTSEL OCH RENGÖRING:

Ett spänt överdrag håller längre och fungerar bättre. Se alltid till att överdraget är spänt. Löst tyg kan göra att överdraget slits snabbare. Ta genast bort snö eller is som samlats på taket med en sopkvast, mopp eller annat mjukt redskap. Var väldigt försiktig när du tar bort snö från överdraget – arbeta alltid på utsidan av konstruktionen. Använd INTE verktyg eller redskap med hårda kanter, som skrapor eller skyfflar, för att ta bort snön. Detta kan leda till att överdraget går i sönder. Använd INTE blekmedel eller starka slipmedel för att rengöra tygöverdraget. Överdraget rengörs enkelt med mild tvål och vatten.

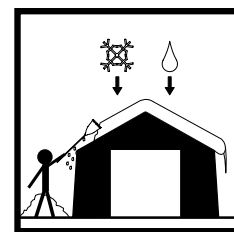

GARANTI:

Detta förvaringsskydd innehar en begränsad garanti avseende tillverkningsfel. Glasfiber & Plastprodukter AB garanterar den ursprungliga köparen att vid korrekt användning och installation att produkten och alla tillhörande delar ifrån tillverkaren är fria från fel under en period av 2 år.

2 års – garanti gäller för skyddsöverdraget, gavelribbor och ramverk.

Garantin börjar gälla från och med det datum transporten påbörjas ifrån Glasfiber & Plastprodukter AB, vid köp direkt ifrån fabrik eller datum för köp ifrån en auktoriserad återförsäljare, (v.g. spara en kopia av inköpskvittot). Om denna produkt eller någon tillhörande del visar sig vara defekta eller saknas vid tidpunkten för leverans, kommer Glasfiber & Plastprodukter AB att reparera eller byta ut, efter eget val, de felaktiga delarna utan kostnad för den ursprungliga köparen.

Reservdelar eller reparerade delar kommer att innefattas av garantin under återstoden av den ursprungliga garantitiden. Alla fraktkostnader ansvarar kunden för. Delar och ersättningar kommer att skickas med postförskott. Kunden måste spara den ursprungliga förpackningen för returtransport. Om du har köpt ifrån en lokal återförsäljare, måste alla reklamationer ske med originalkvitto. Efter köpet, fyll i och returnera garantikortet för produktregistrering. Se garantikortet för mer information.

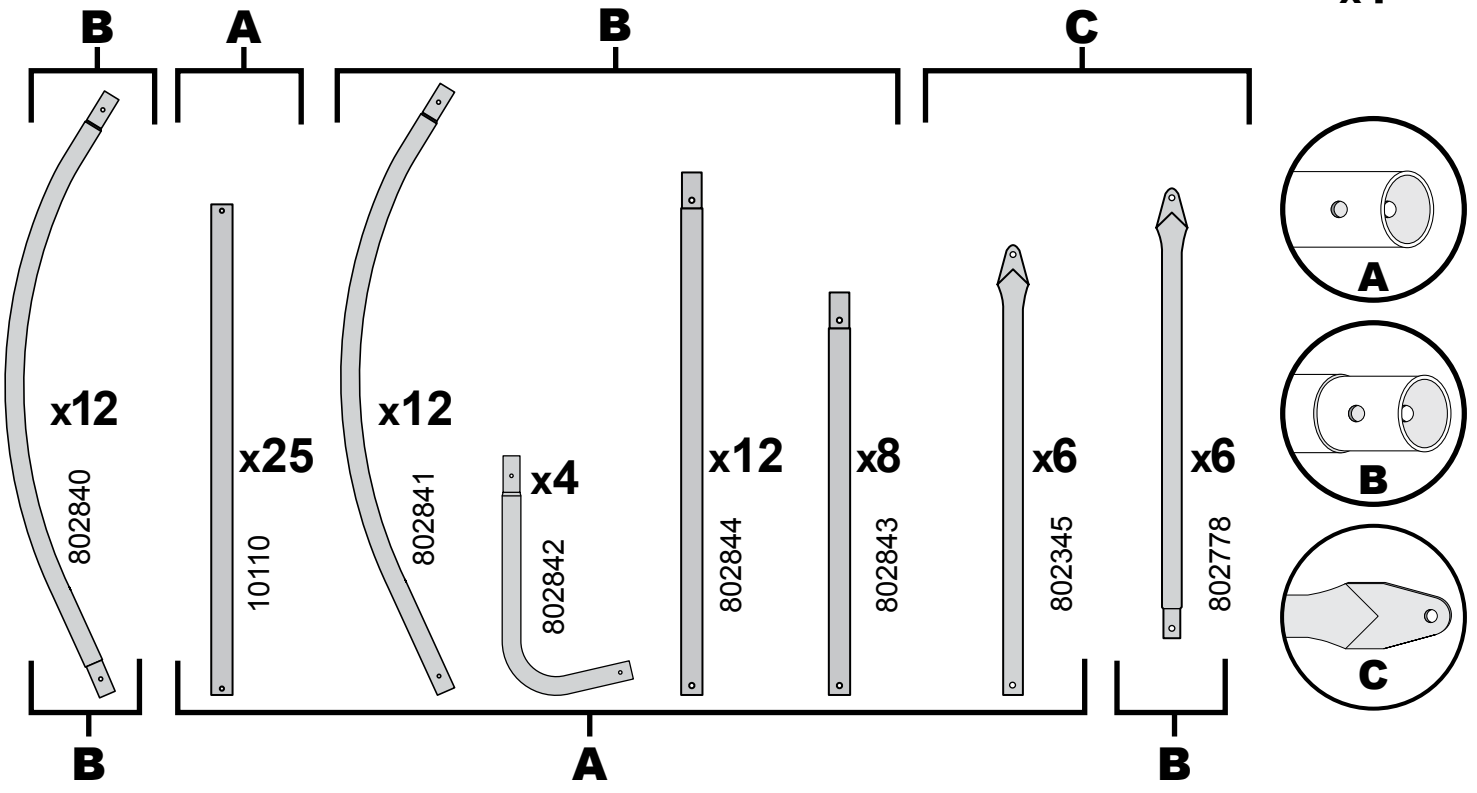
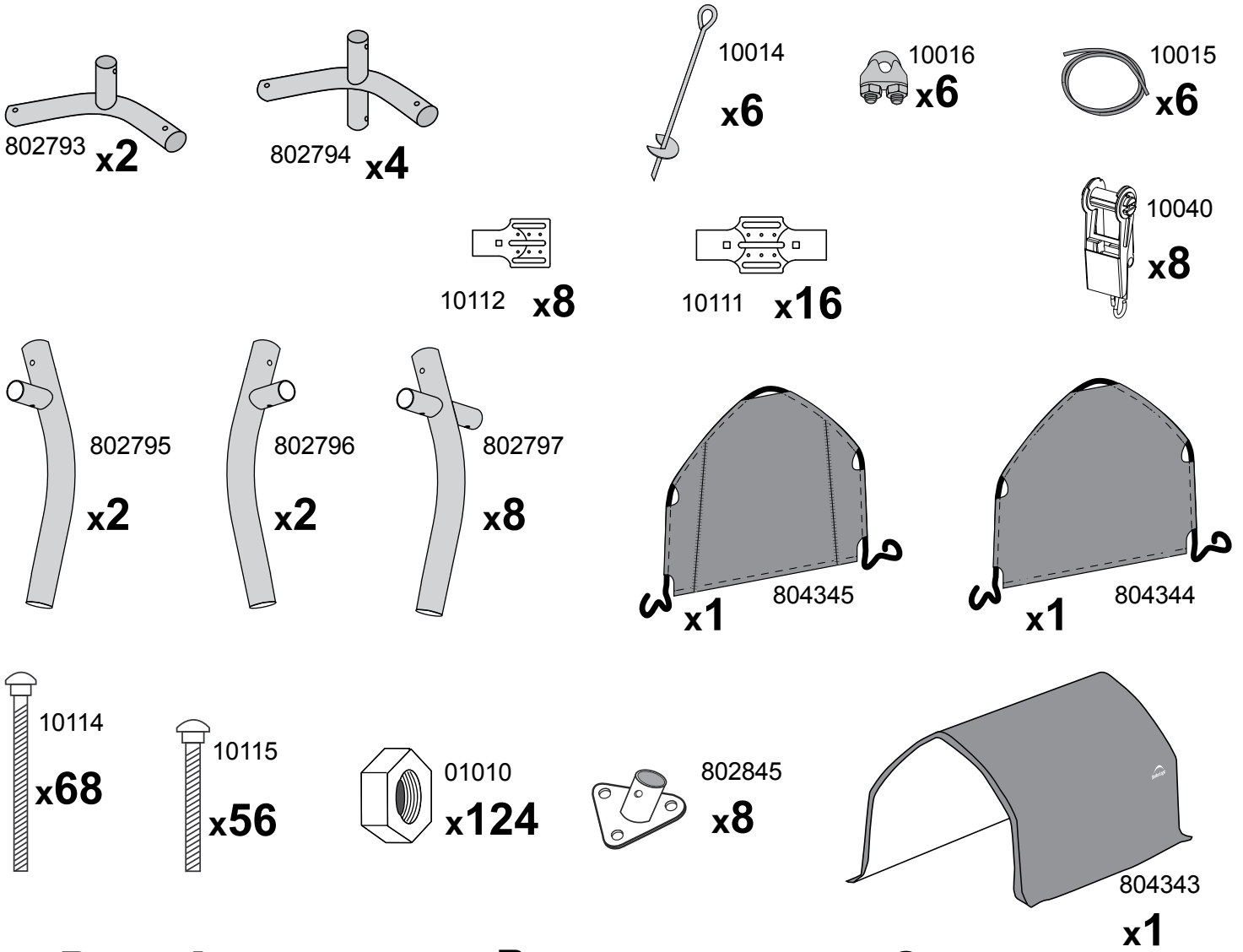

1.

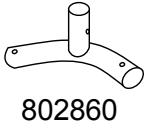

&

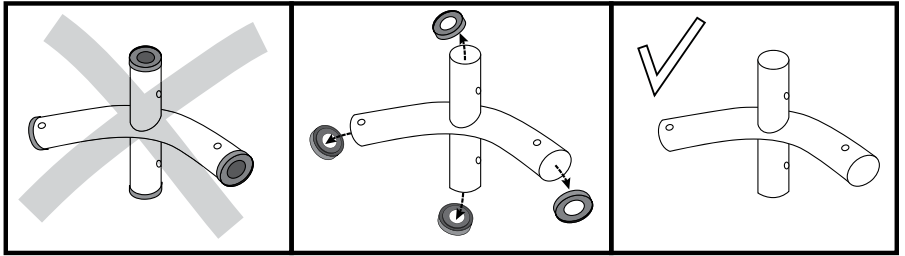
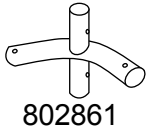

BAKSIDA

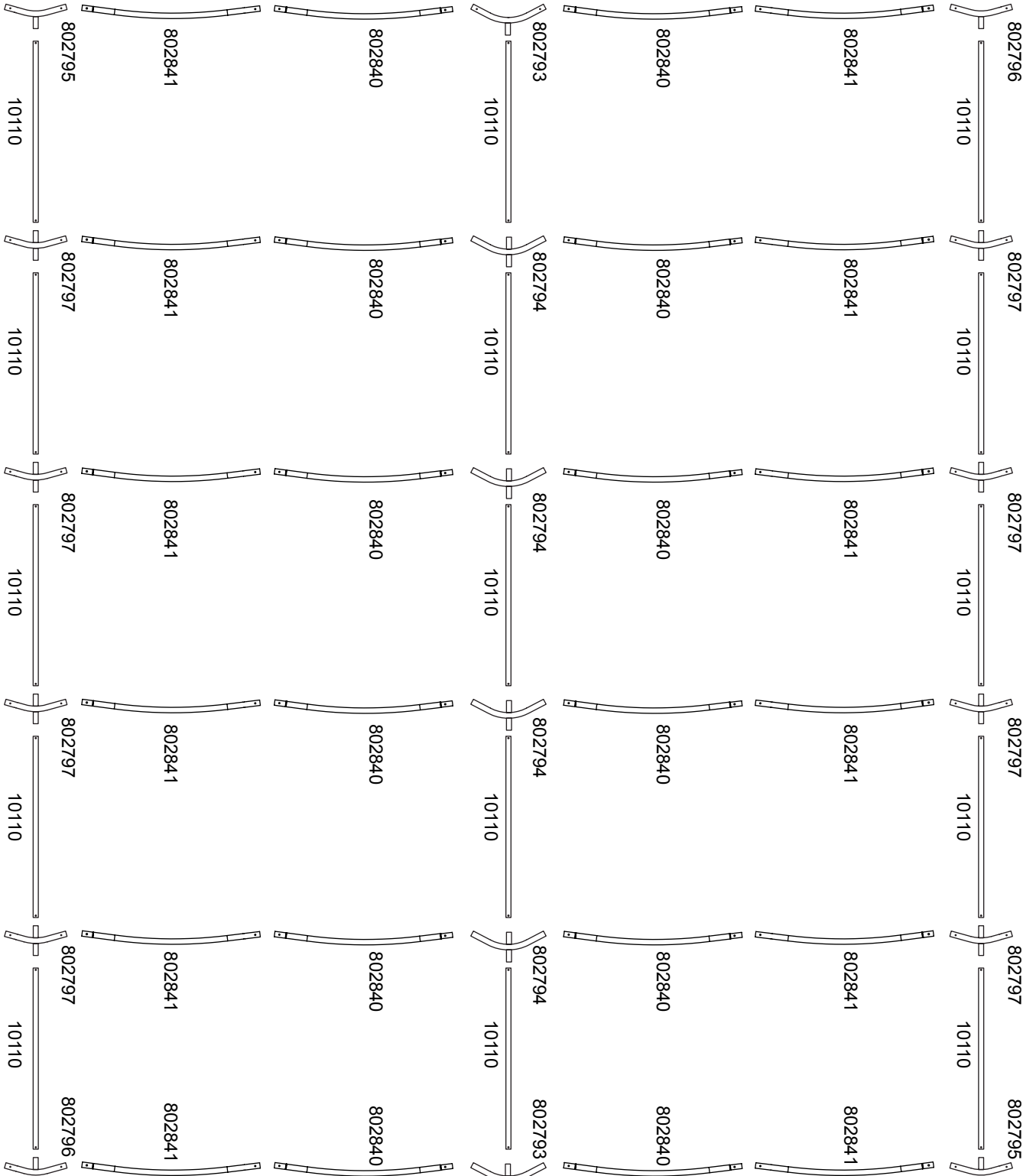

FRANSIDA

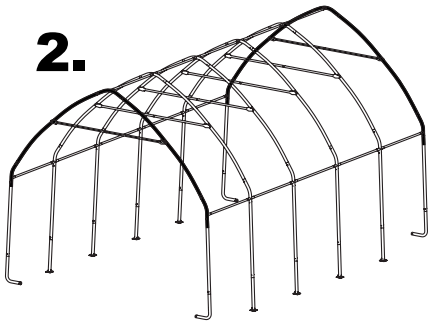

2.

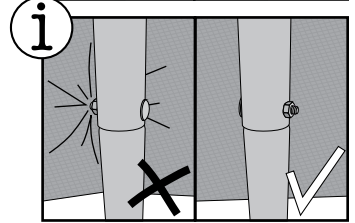
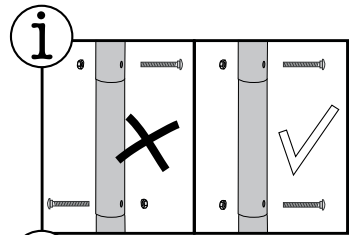

x2

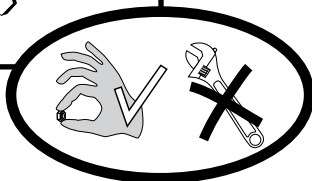
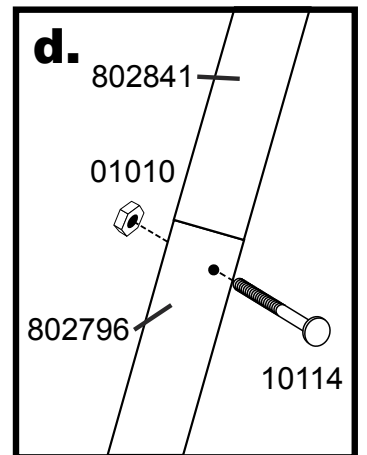
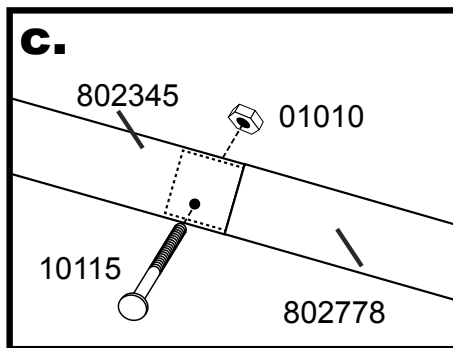
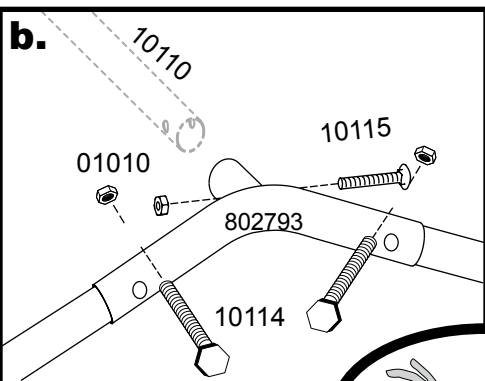
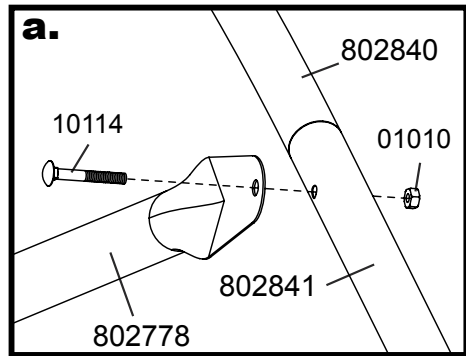
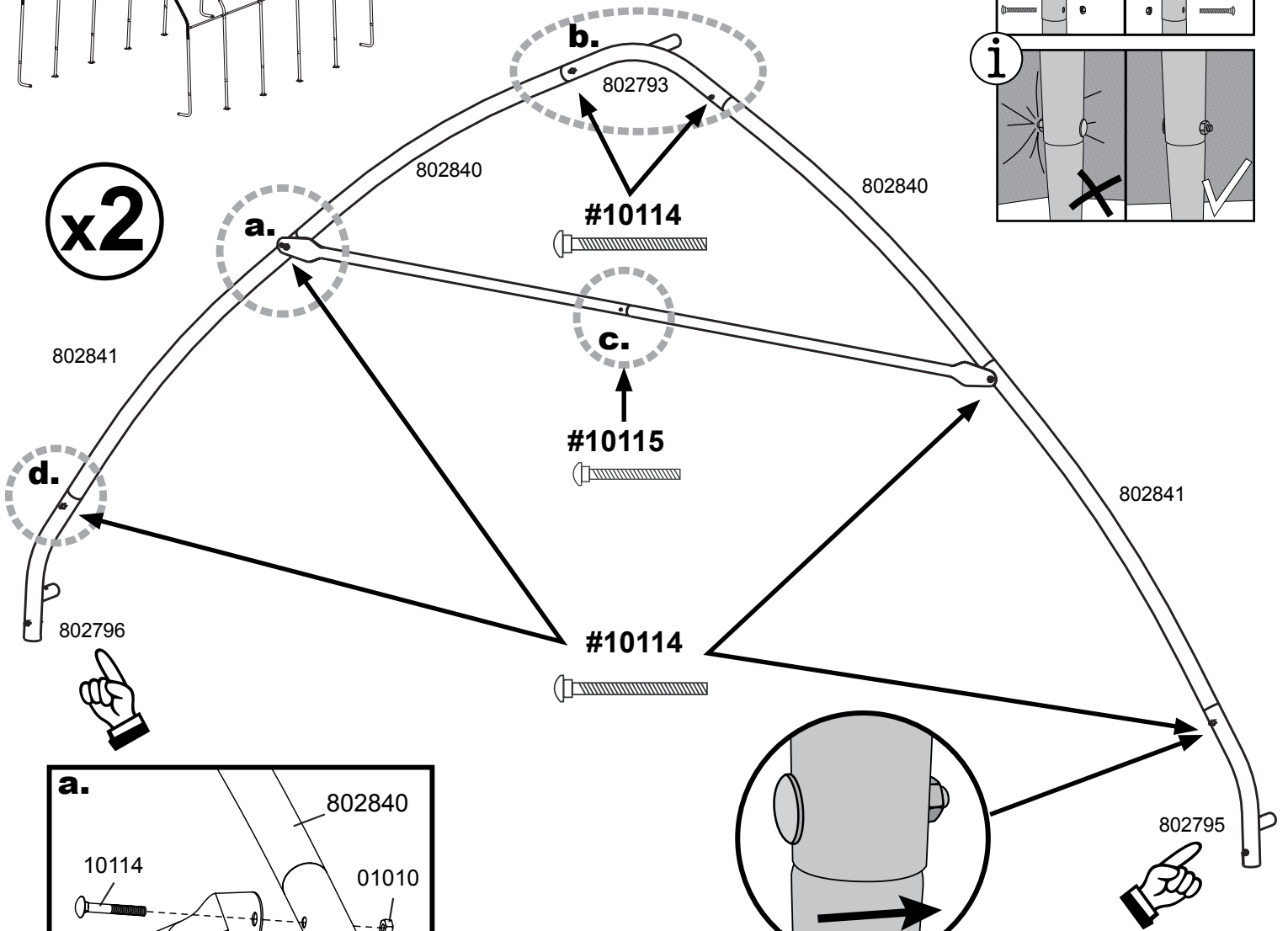

3.

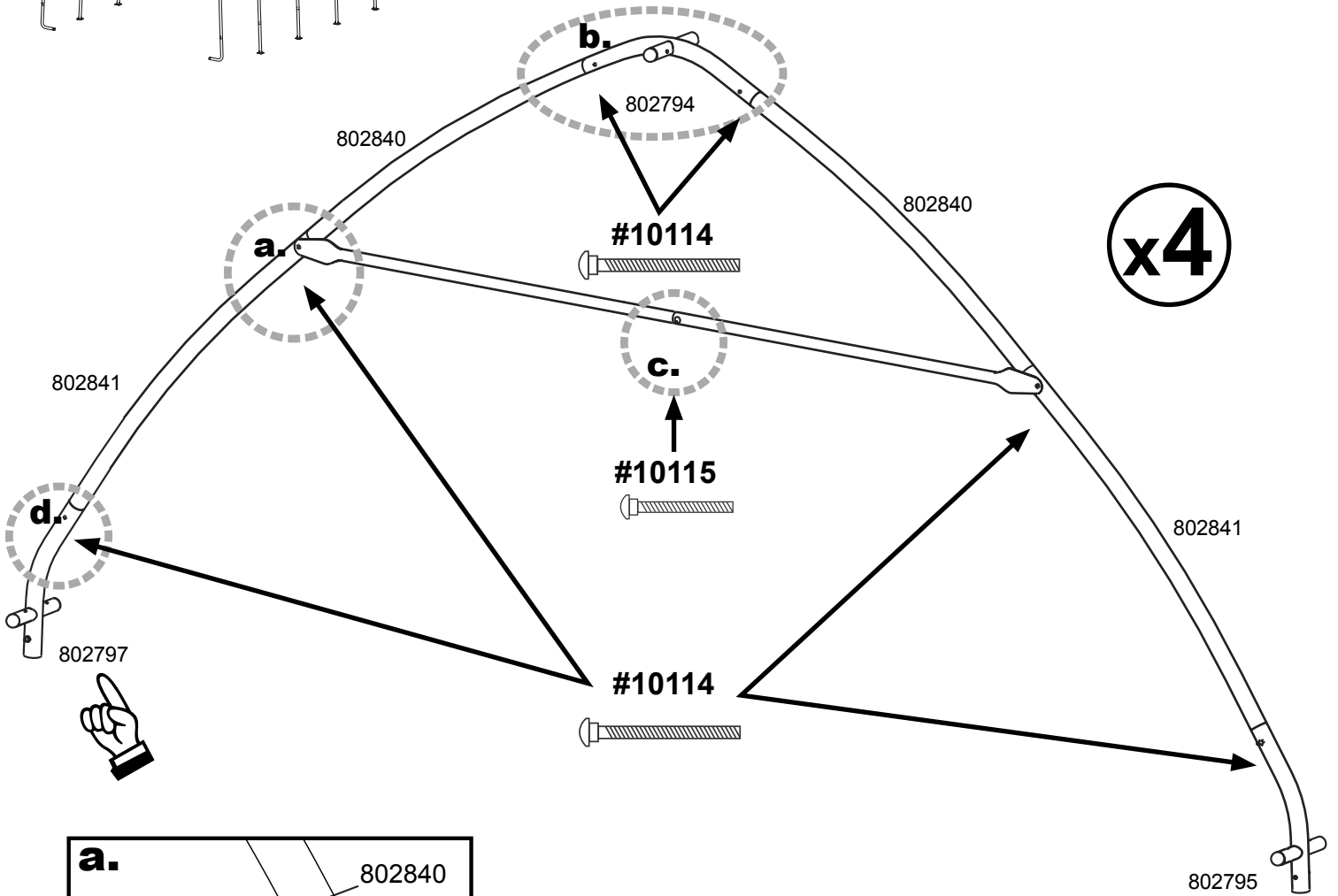
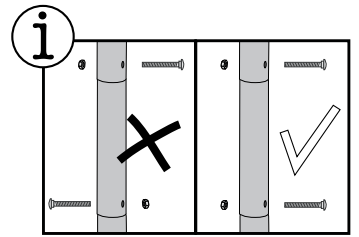
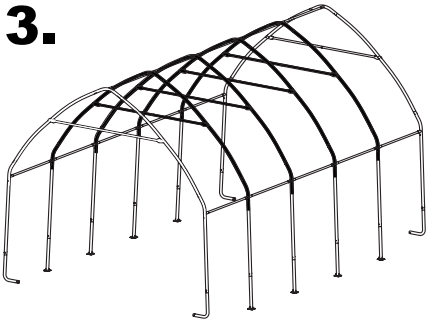

x4

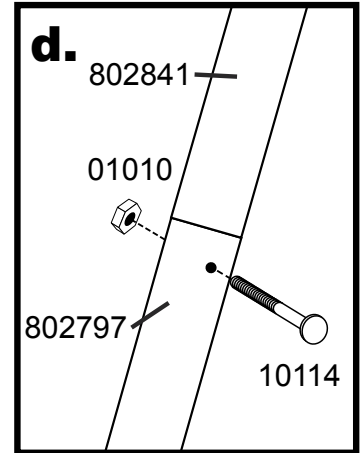
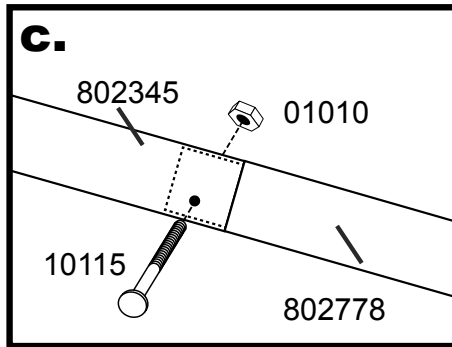
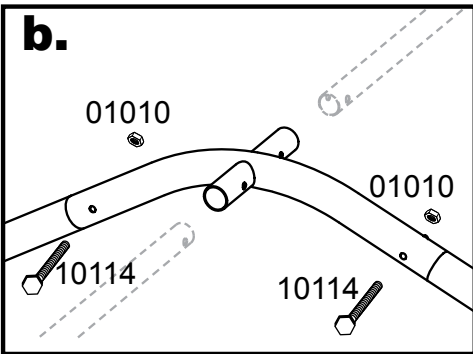
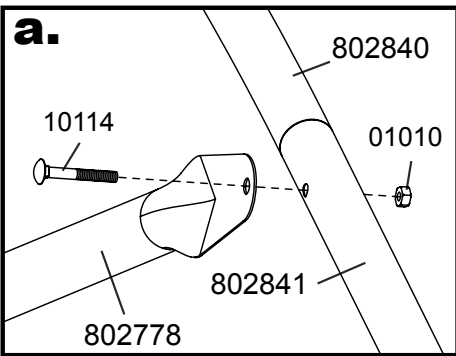

4.

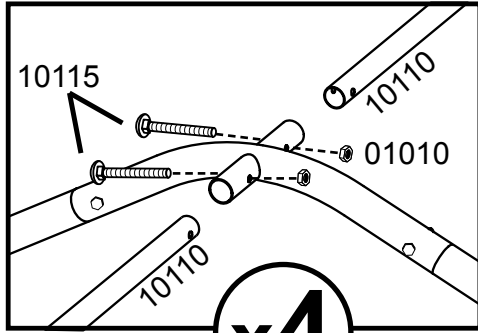
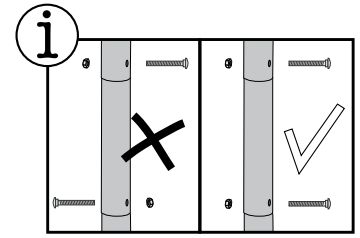
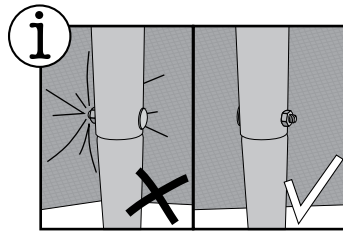

x4

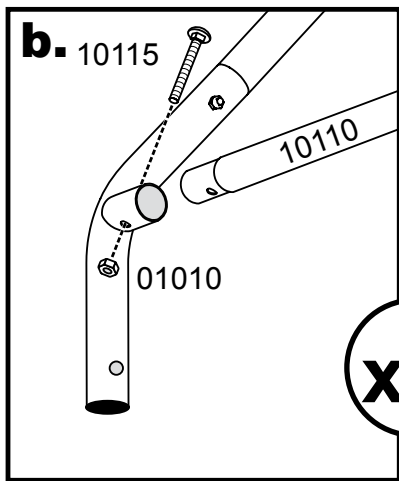
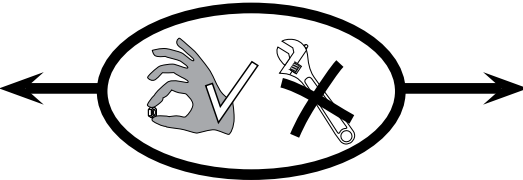
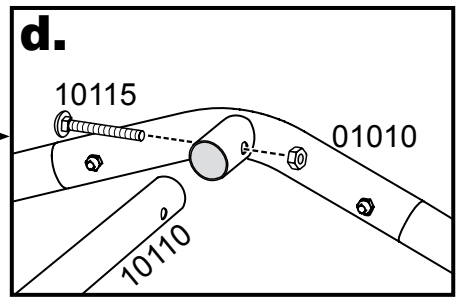
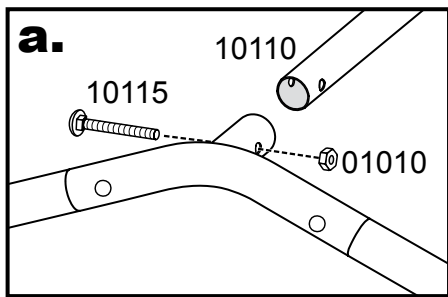
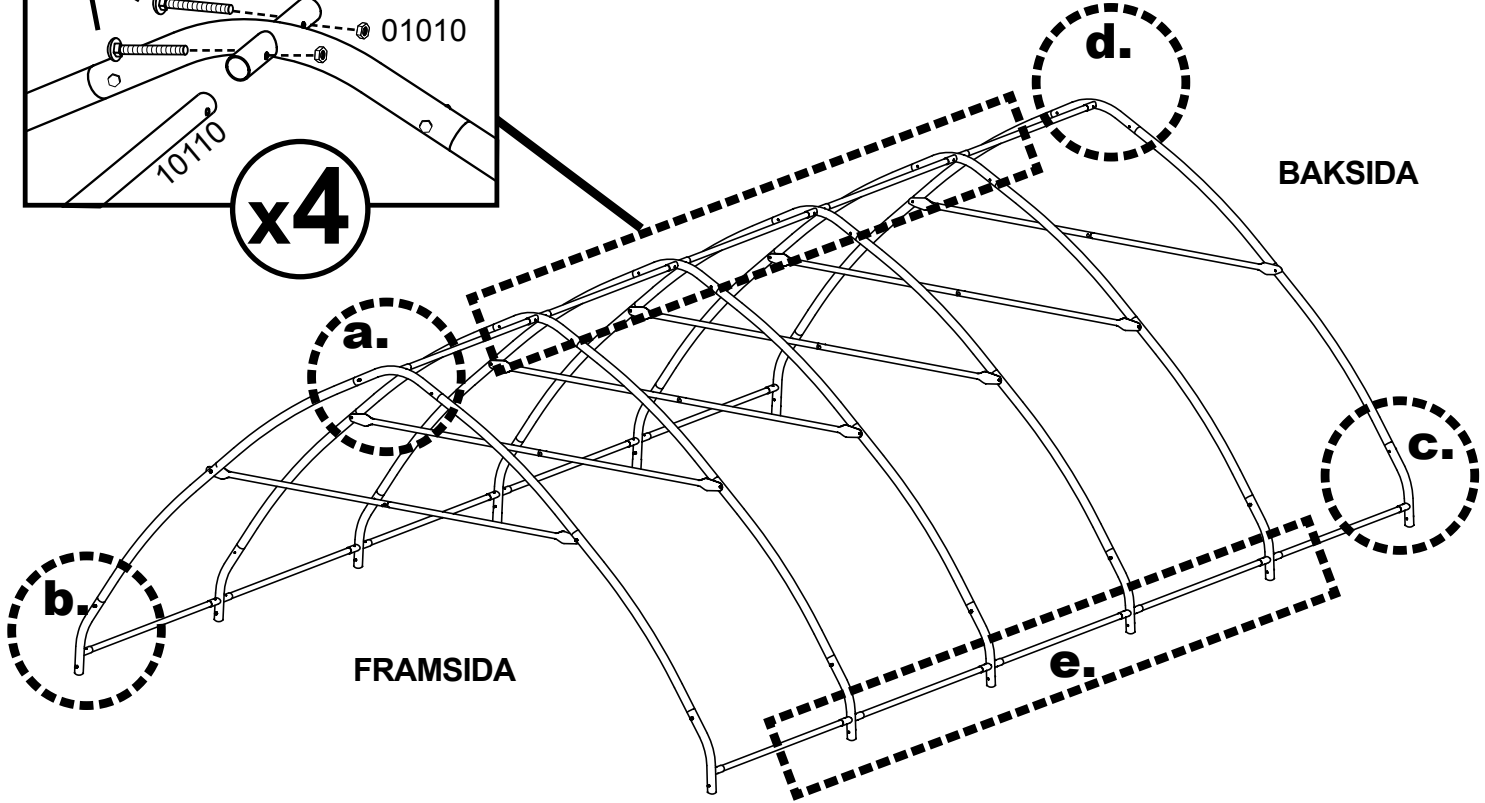

x2

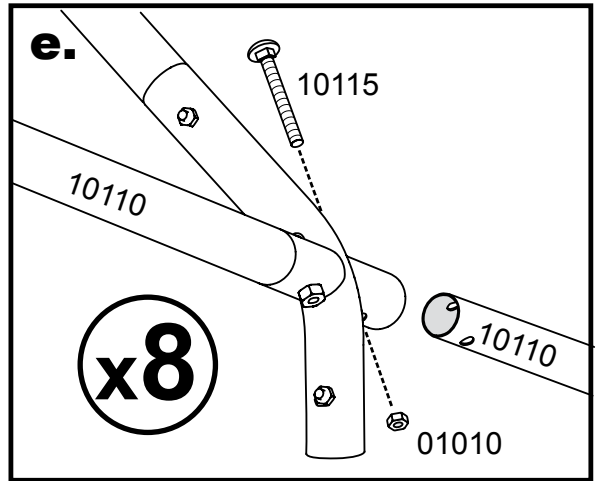
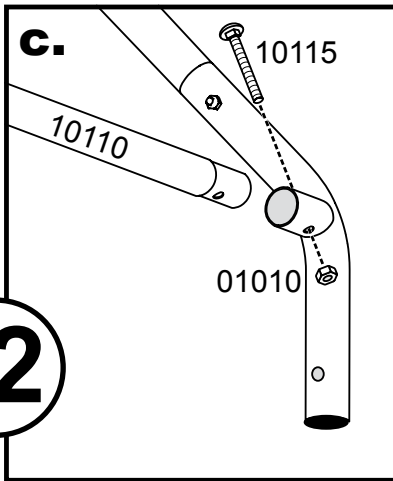

x8

5.

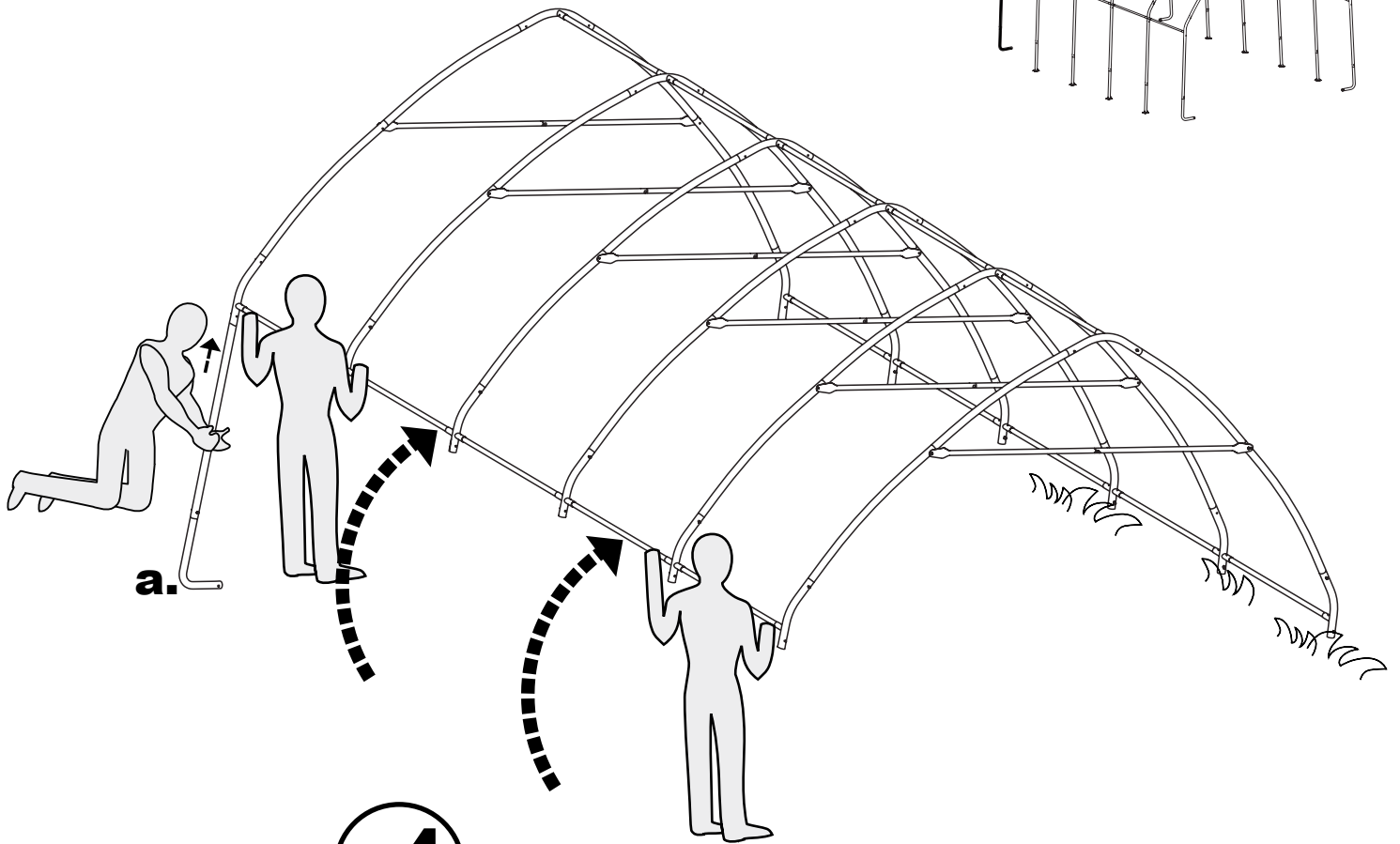
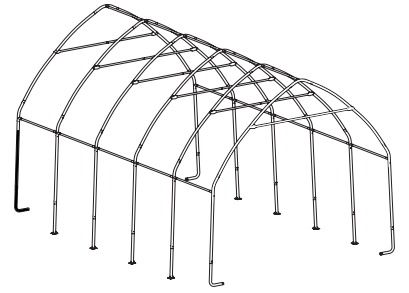
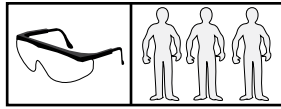

x4

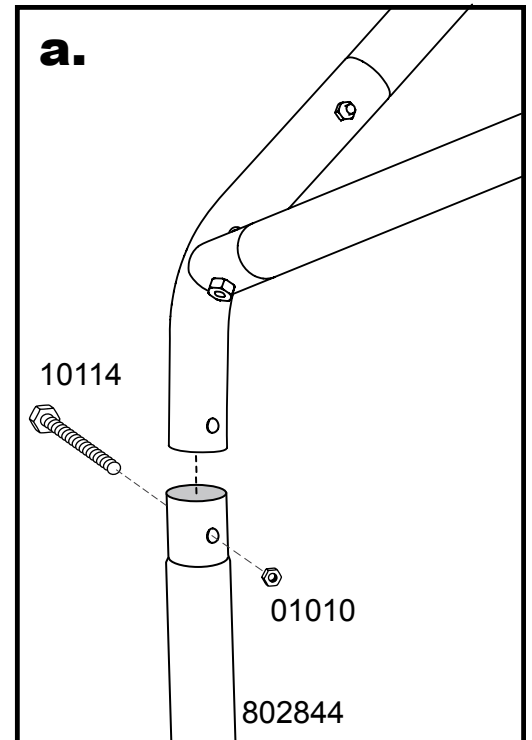
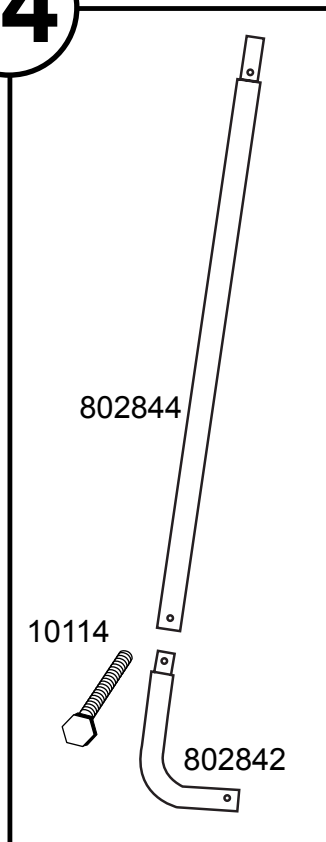
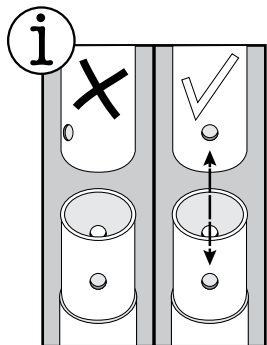

5.

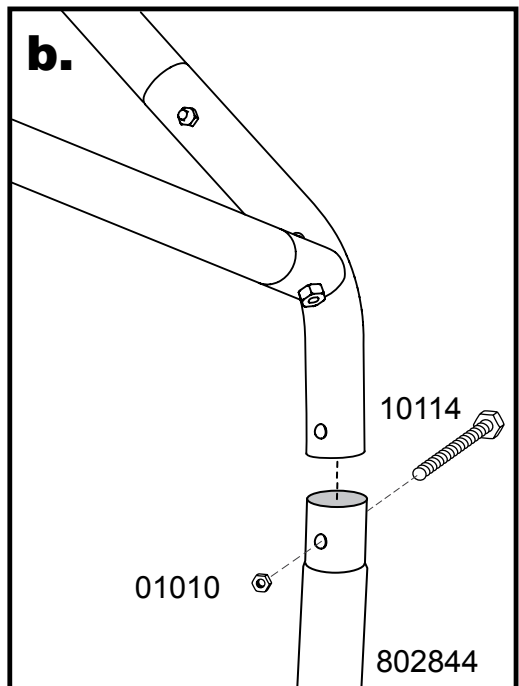
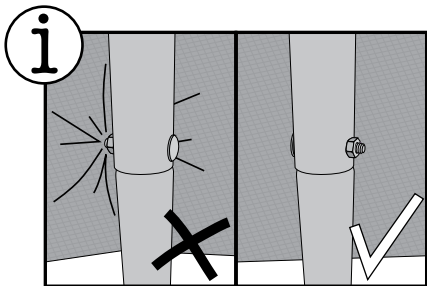
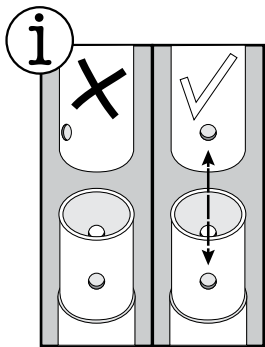
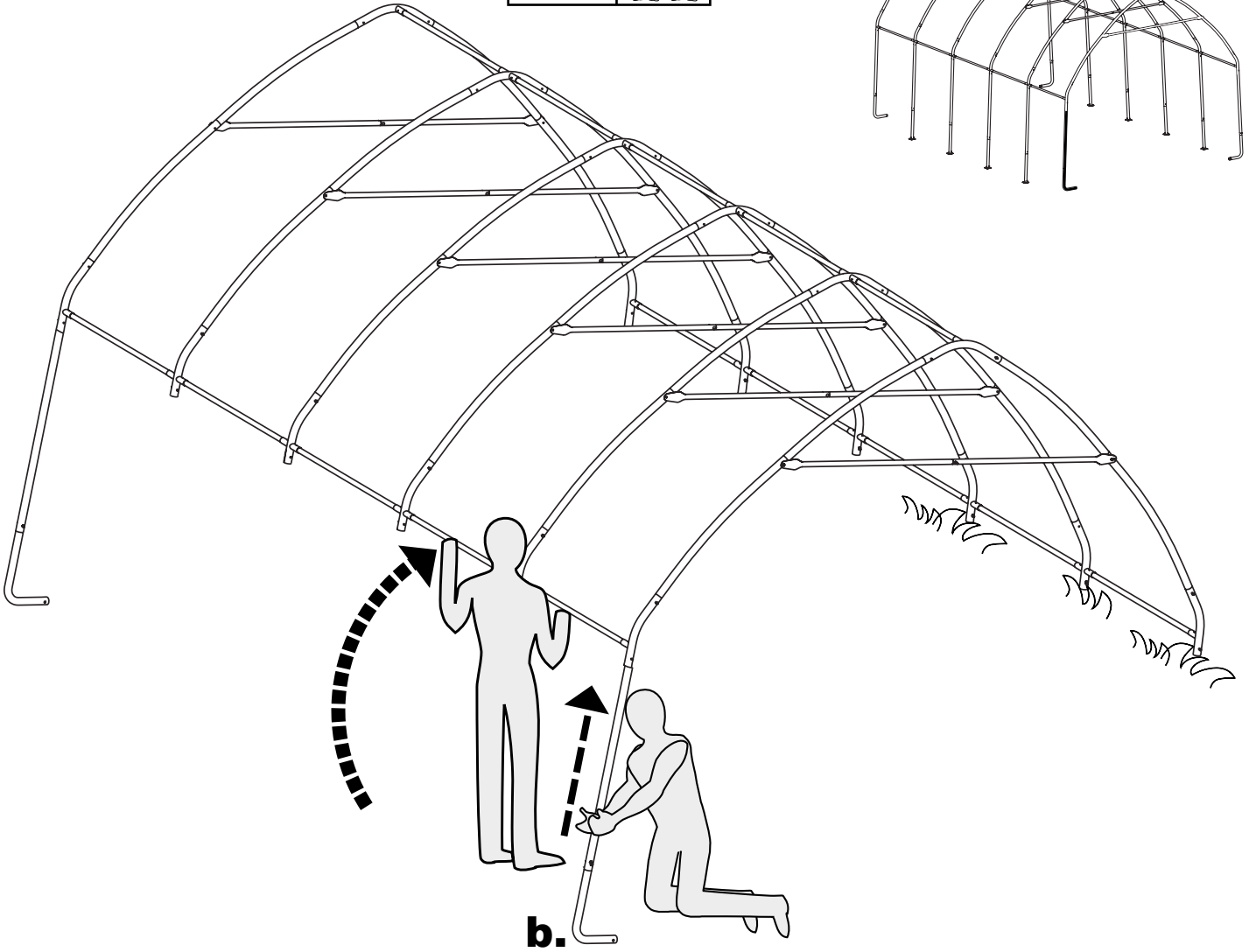
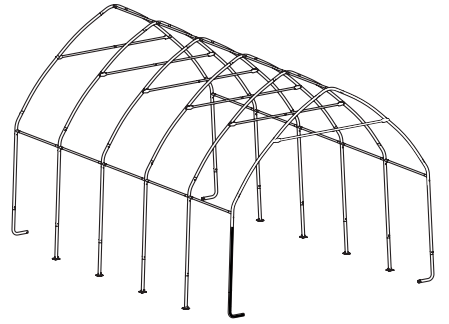
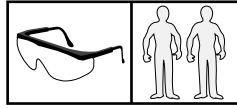

5.

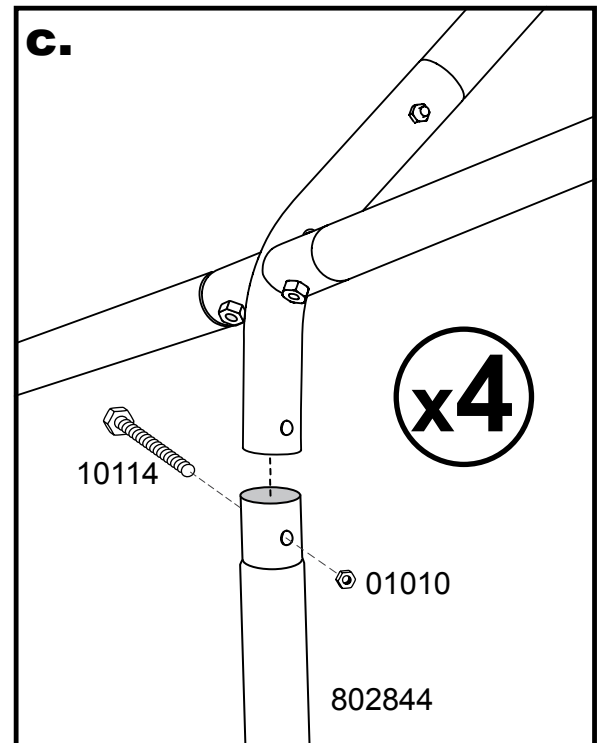
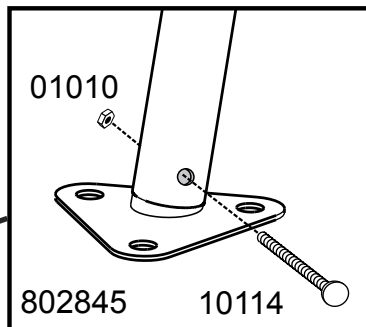
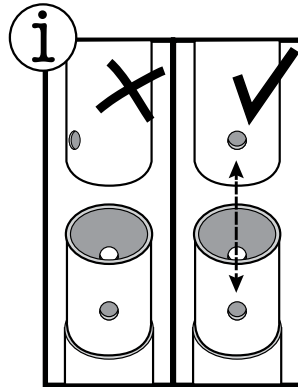
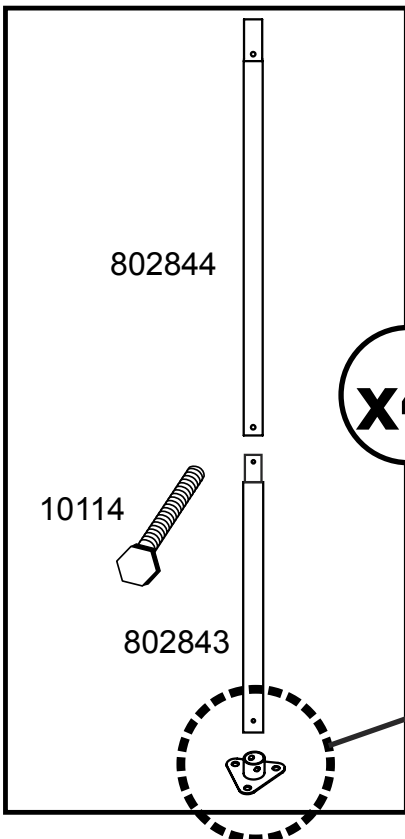
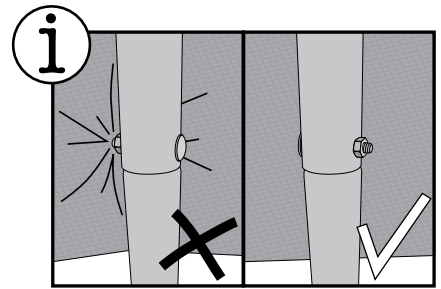
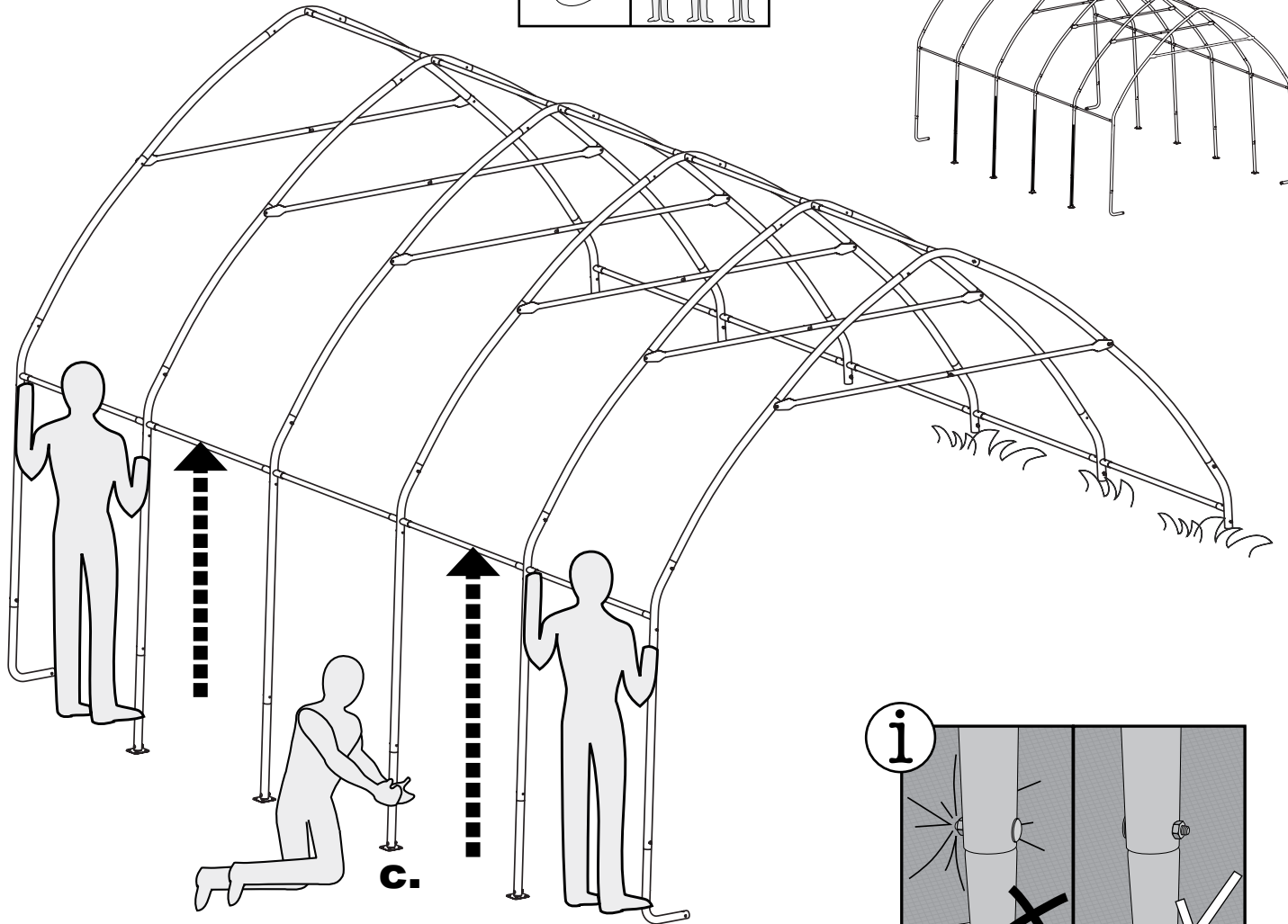
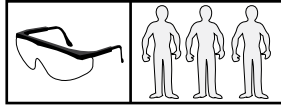

5.

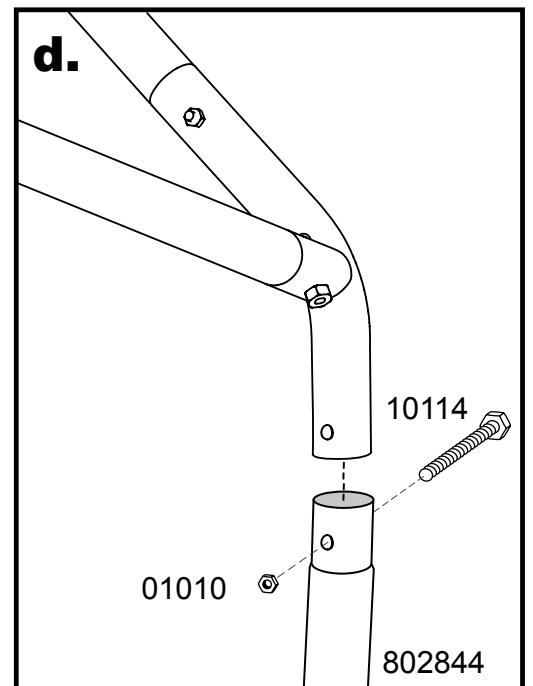
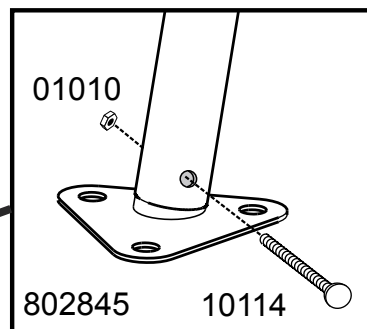
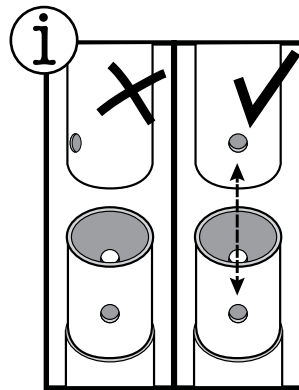
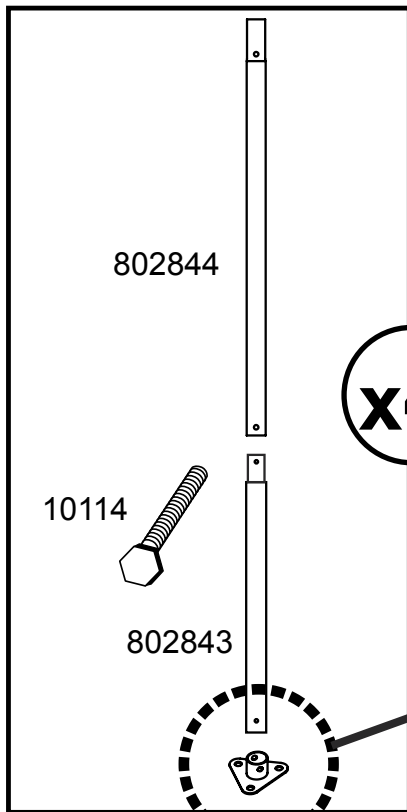
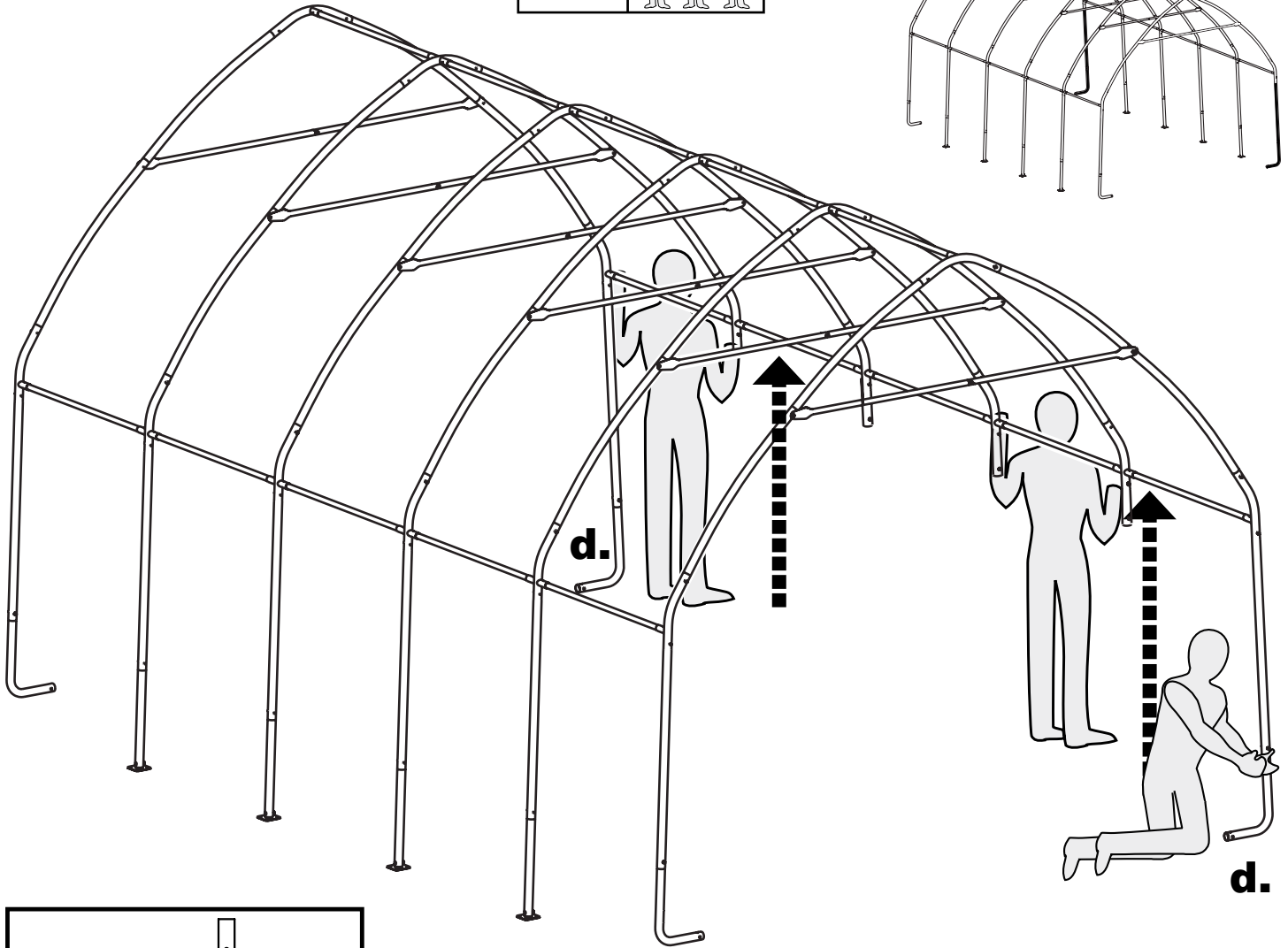
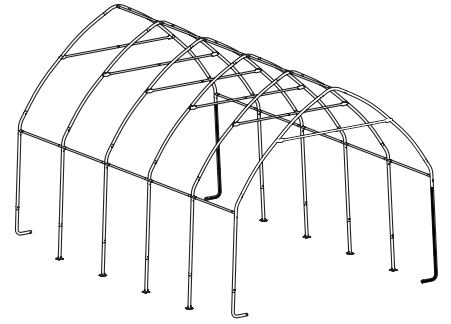
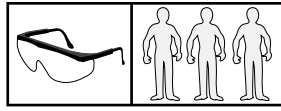

5.

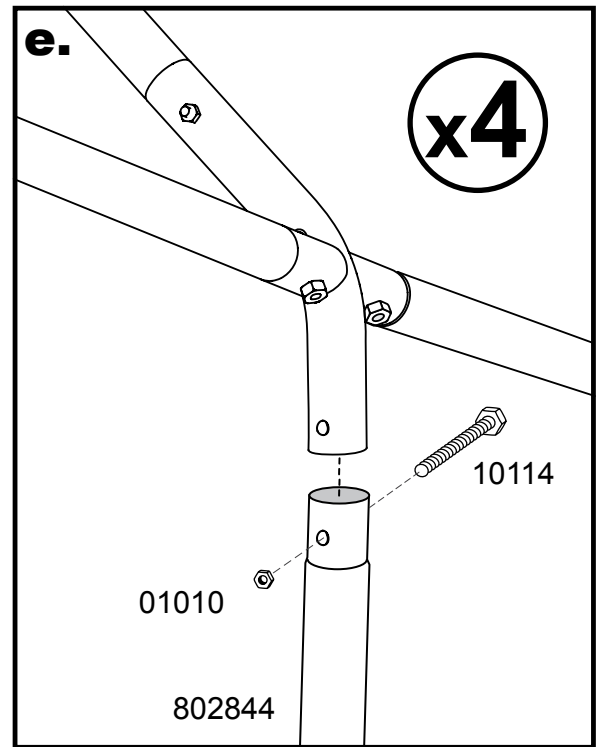
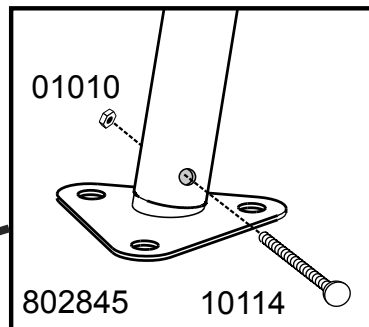
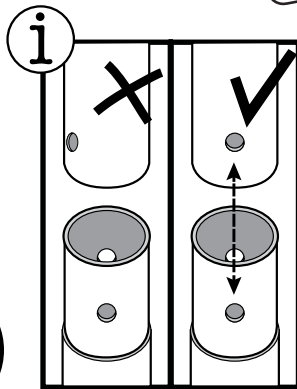
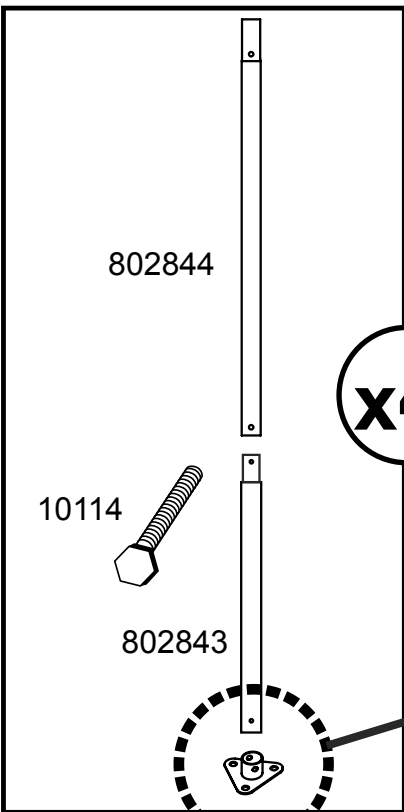
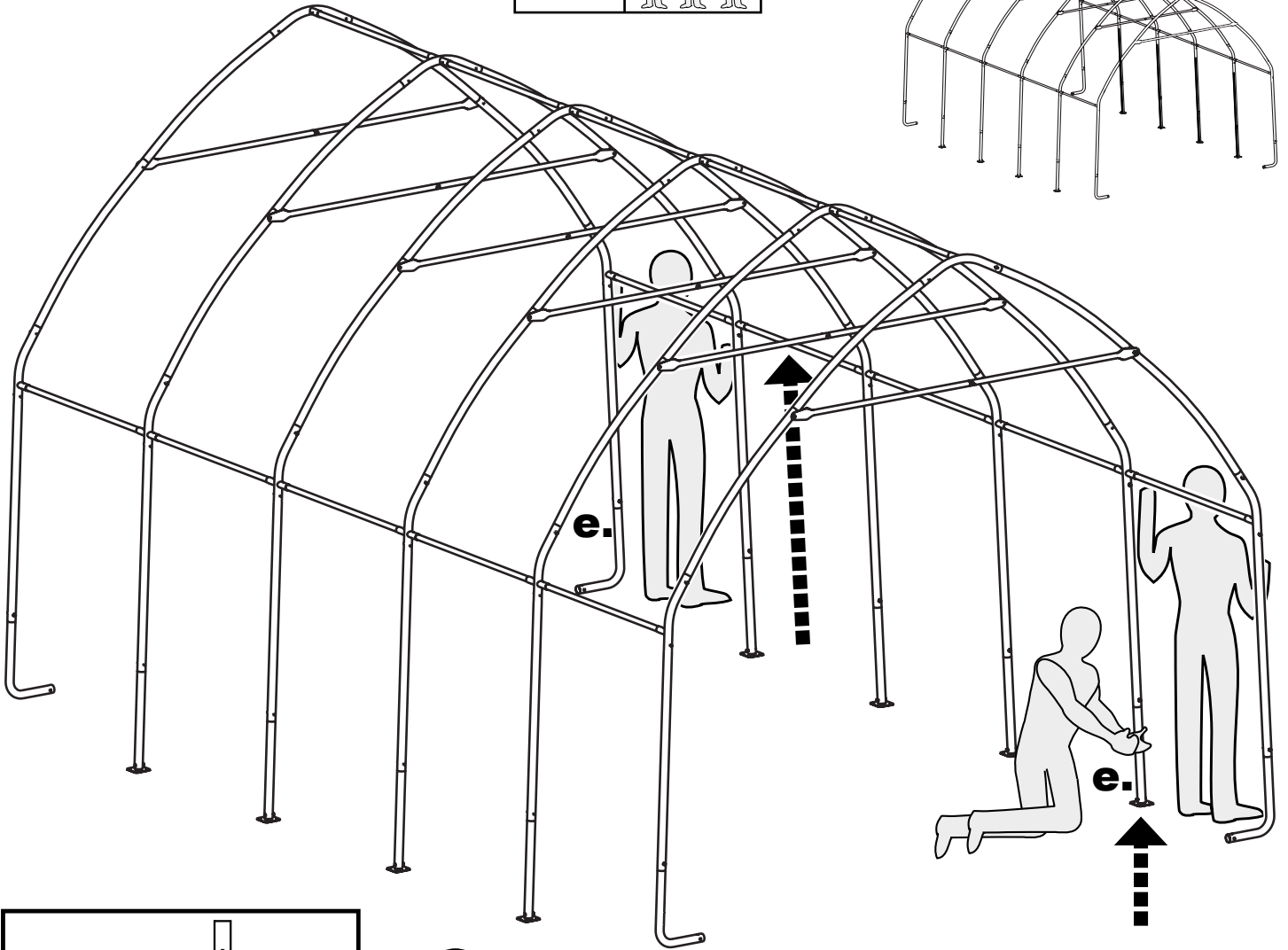
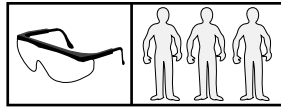

6.

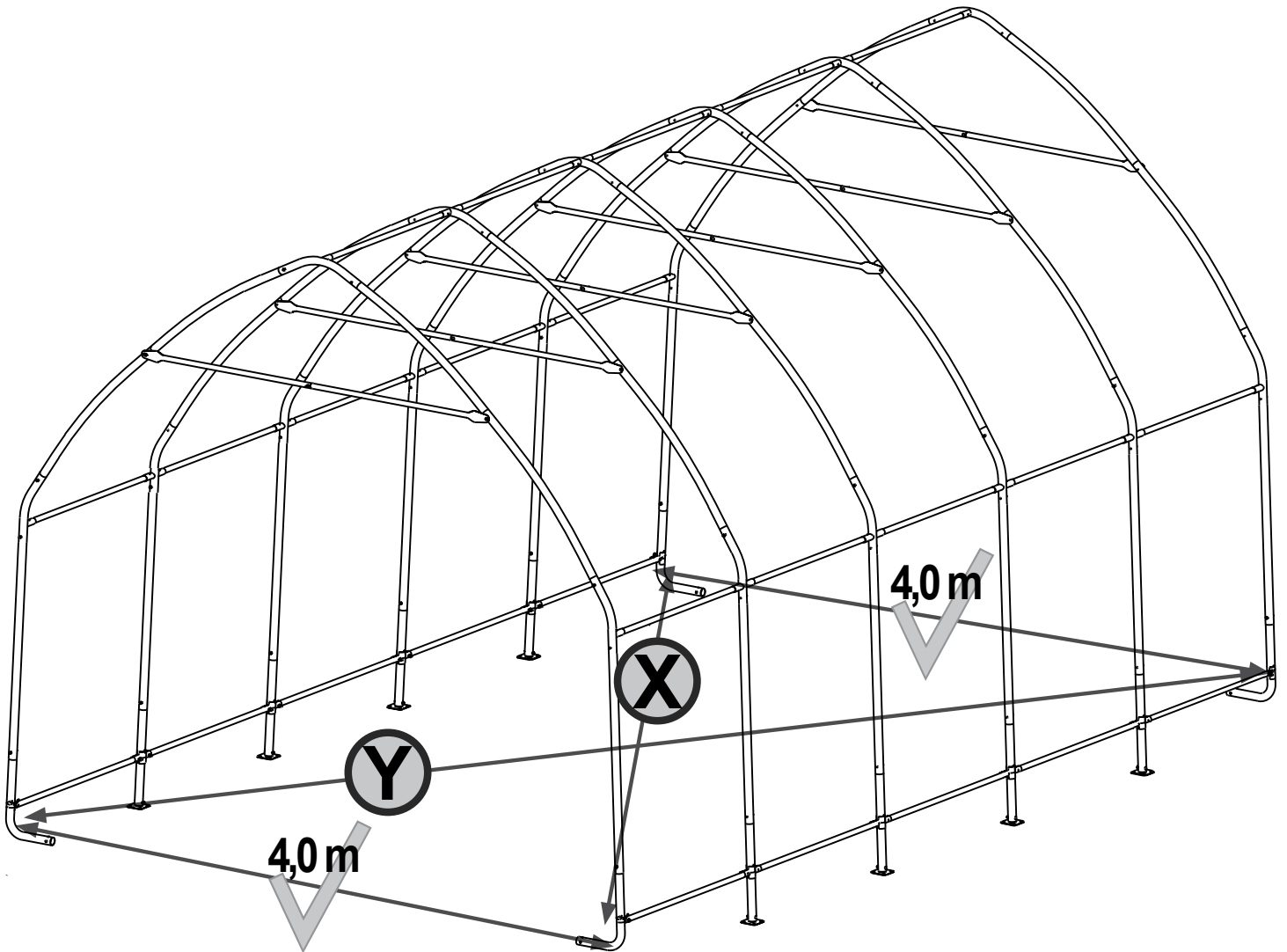
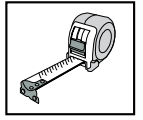

✓ $\textcircled{X} = \textcircled{Y}$
2,5 cm

7.

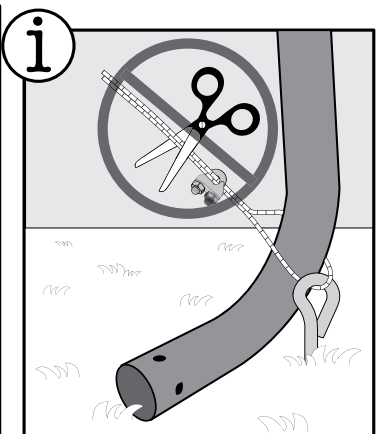
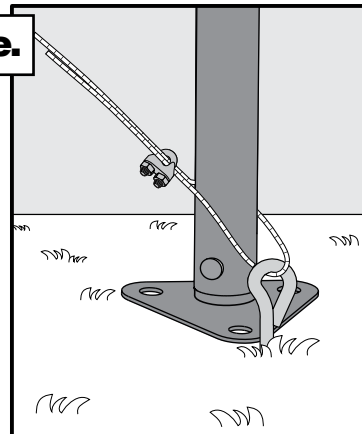
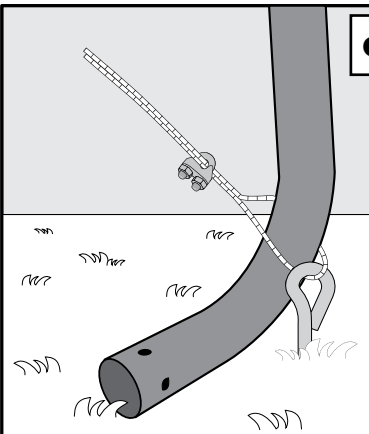
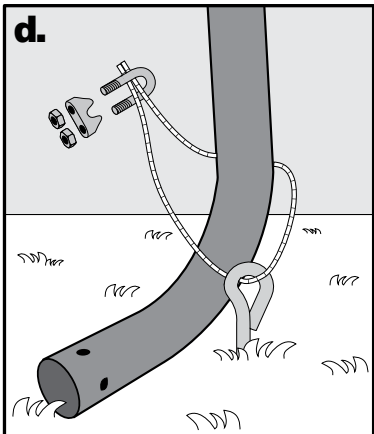
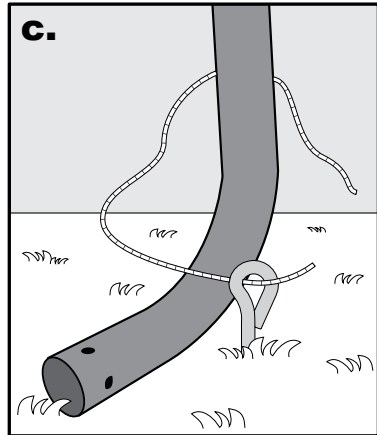
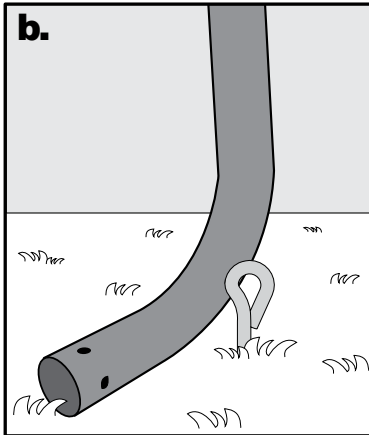
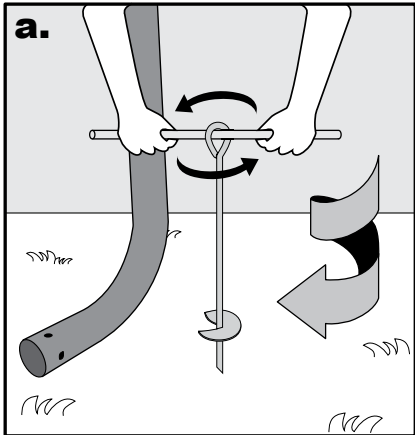
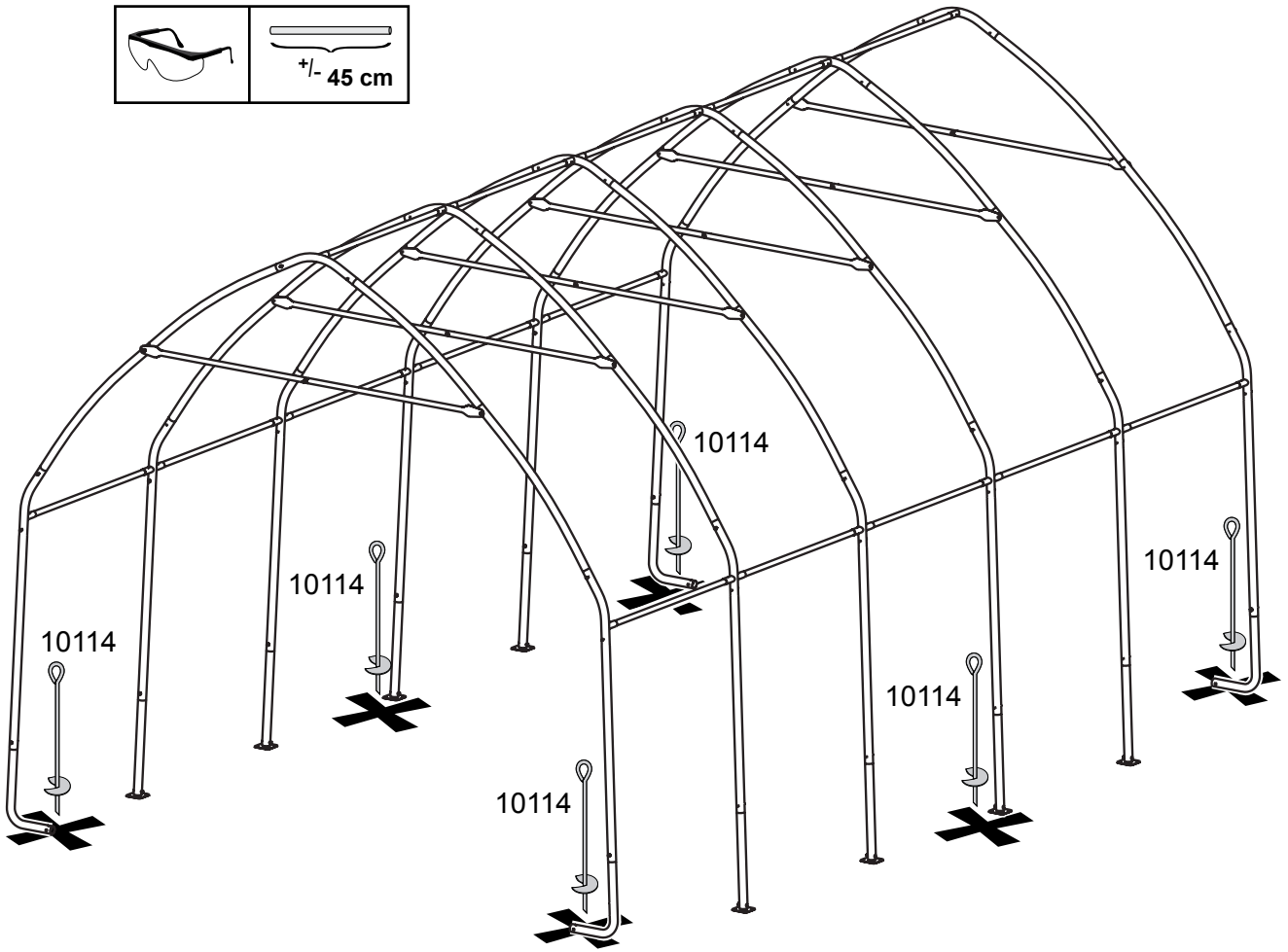
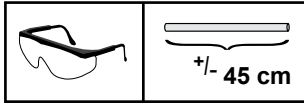

8.

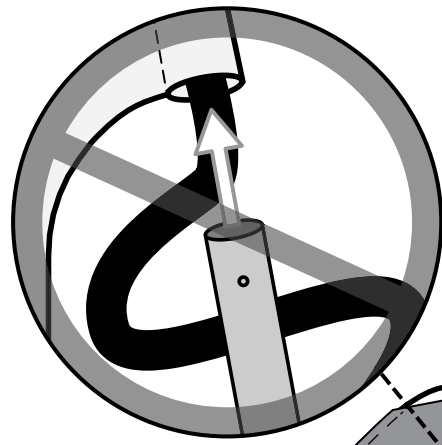
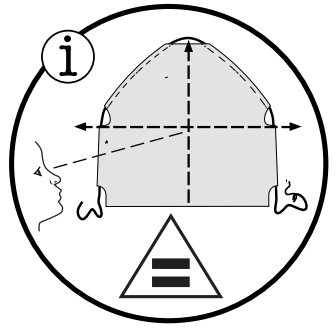
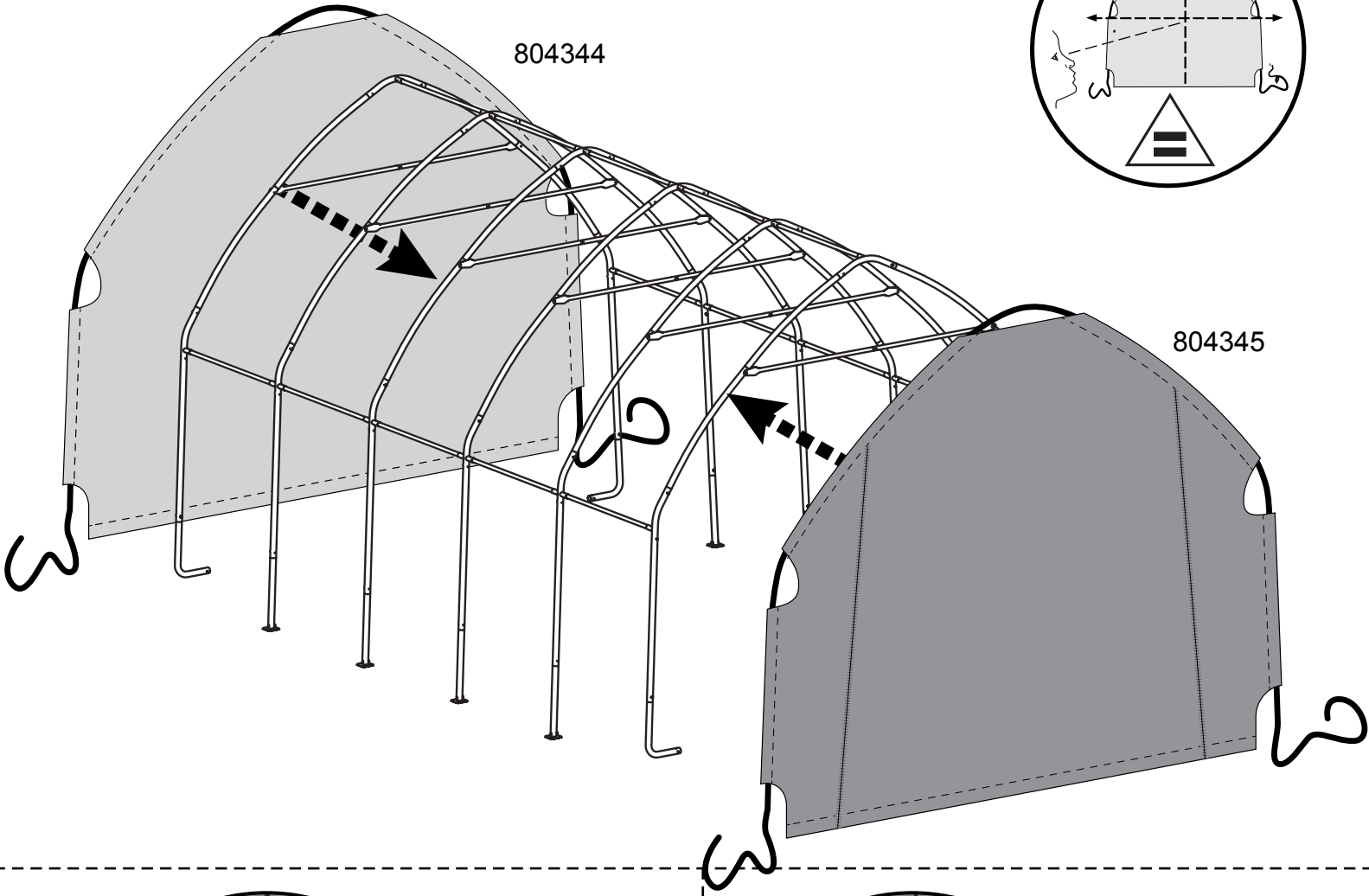

i

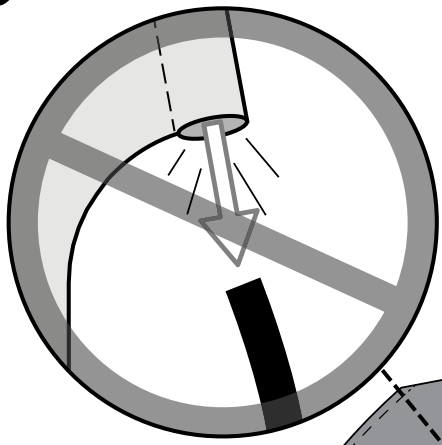

i

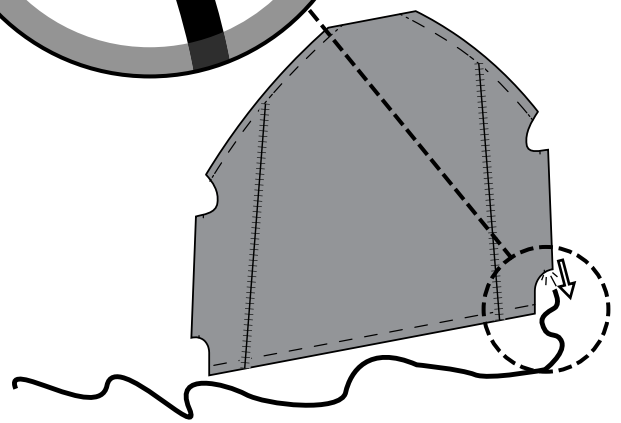
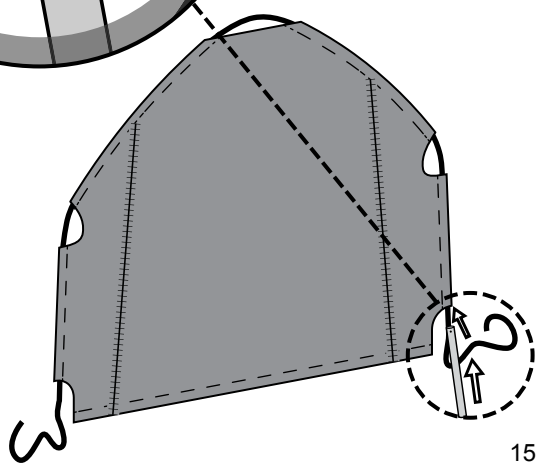

9.

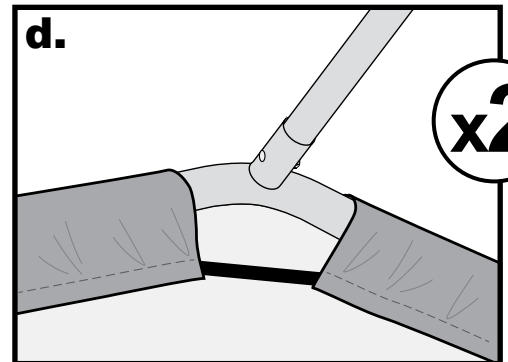
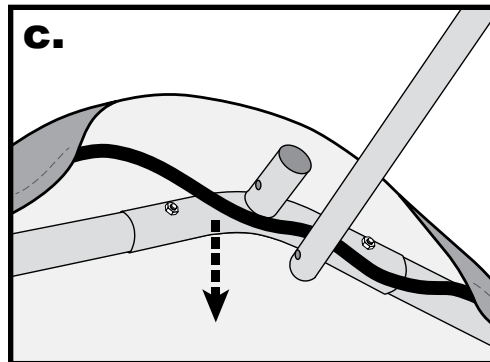
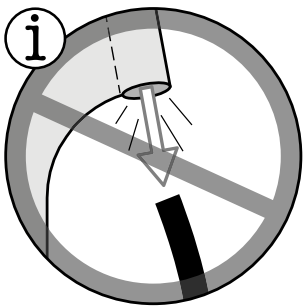
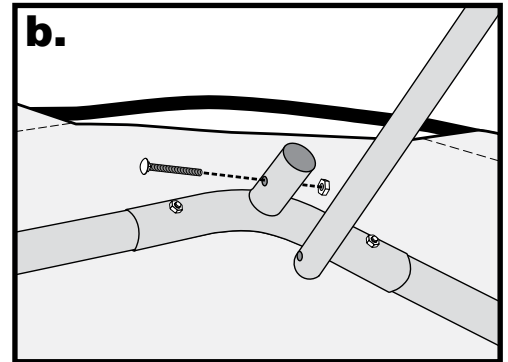
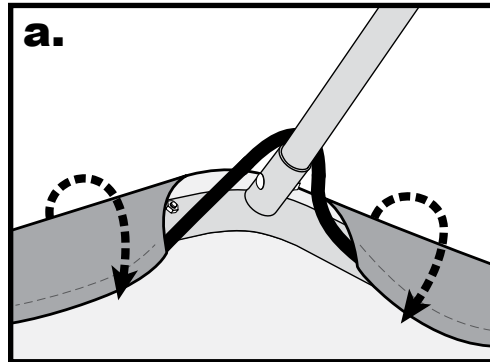
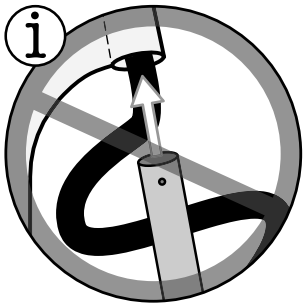
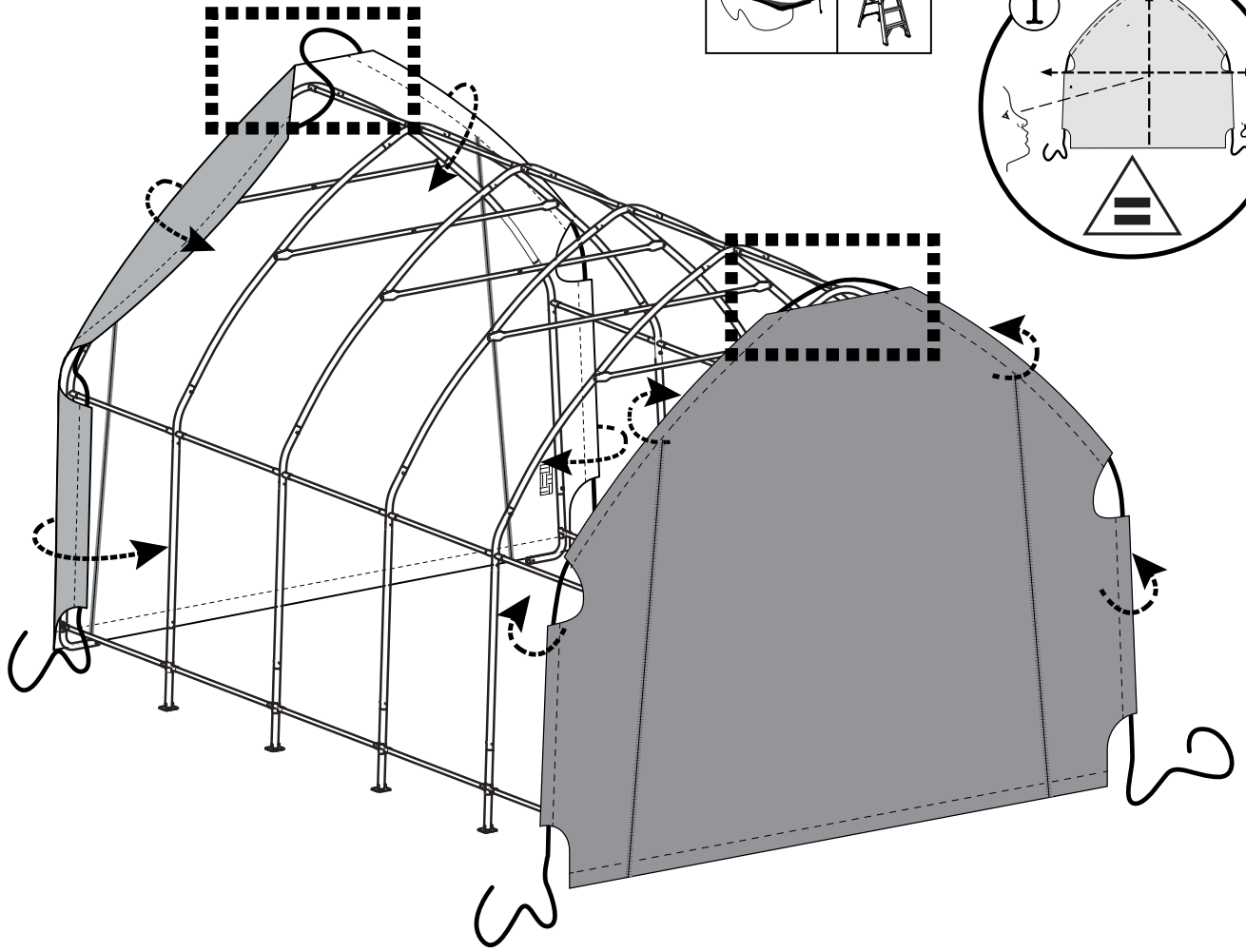
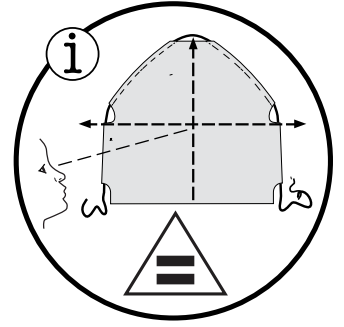
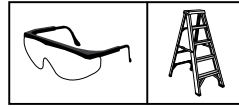

10.

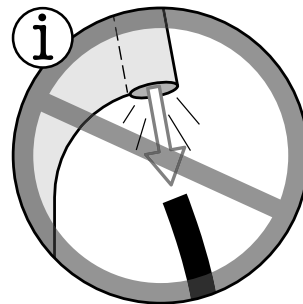
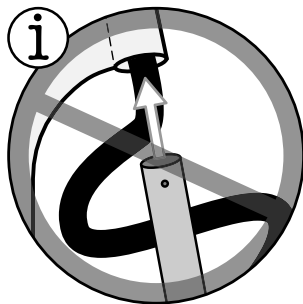
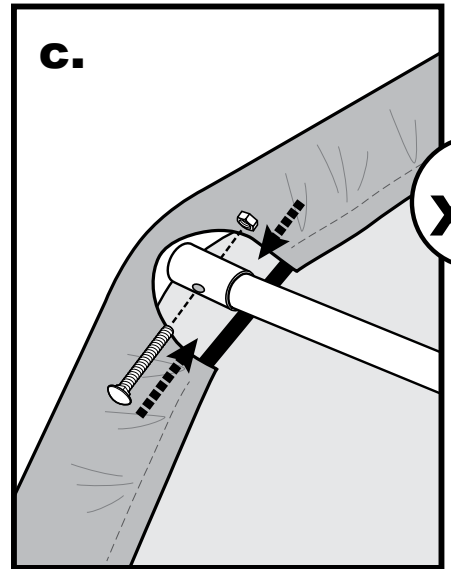
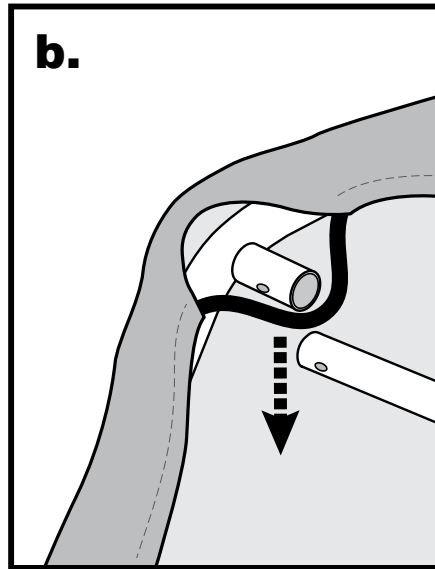
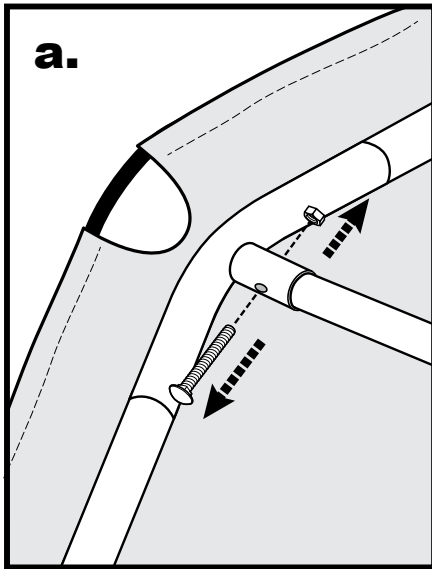
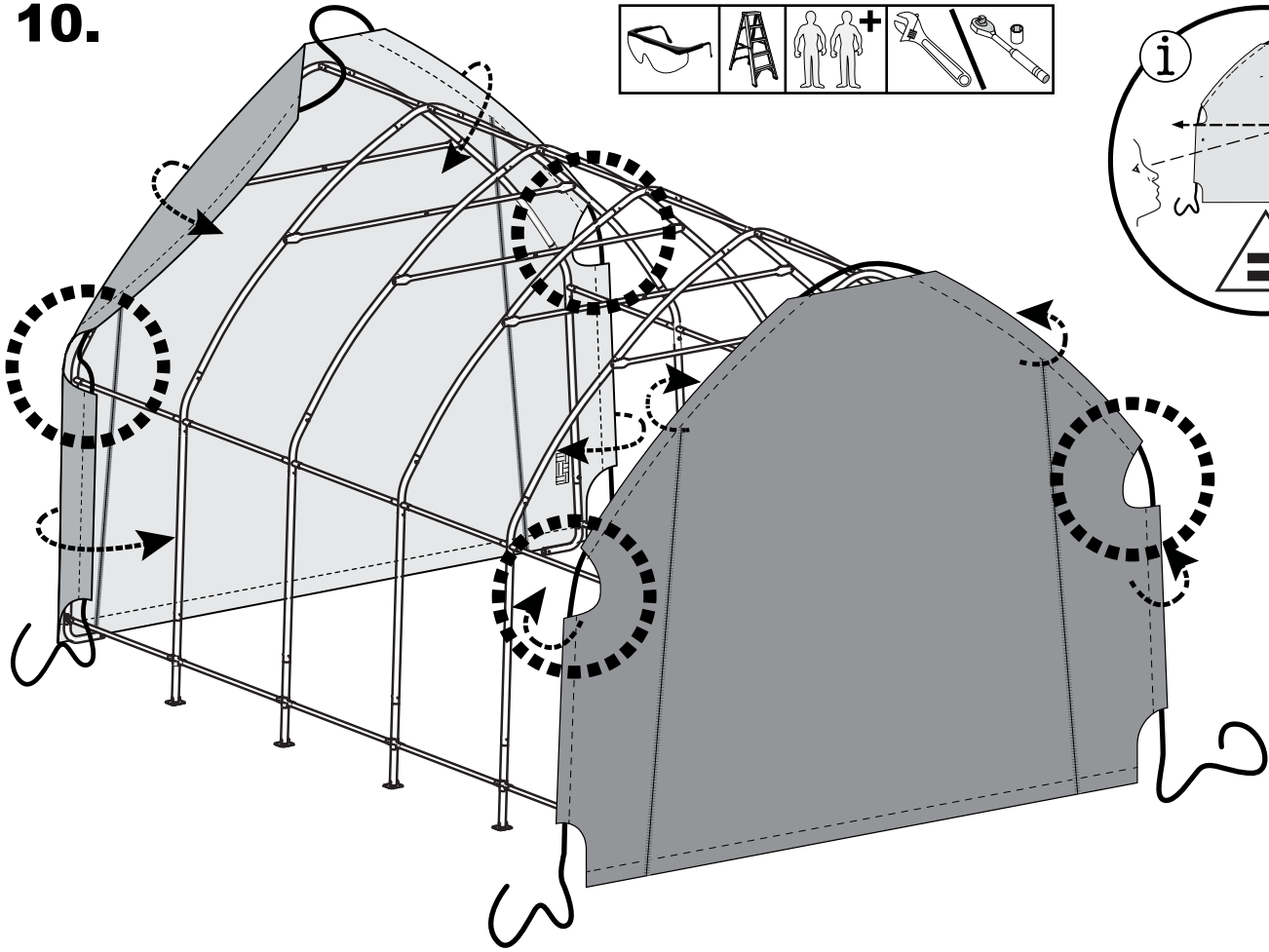
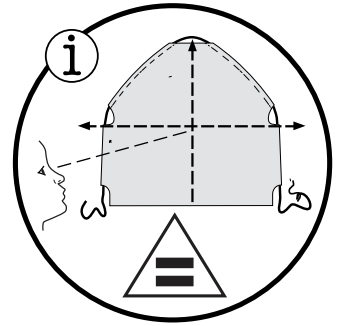
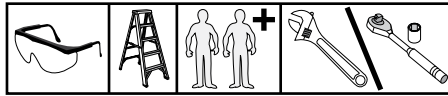

11.

a.

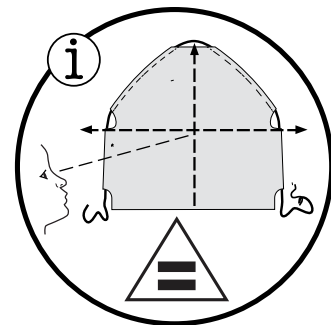
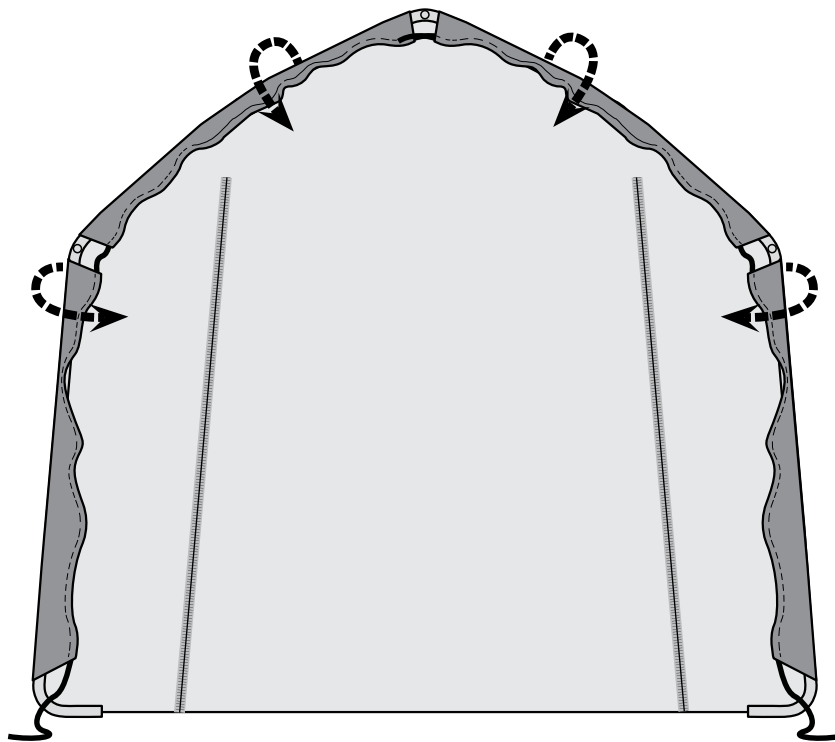

b.

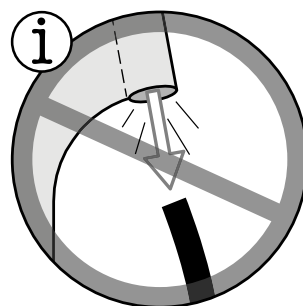
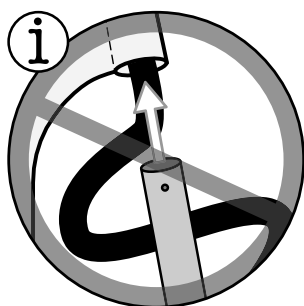
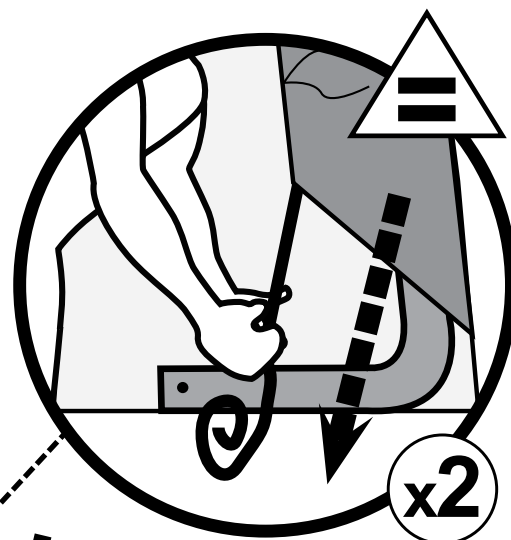
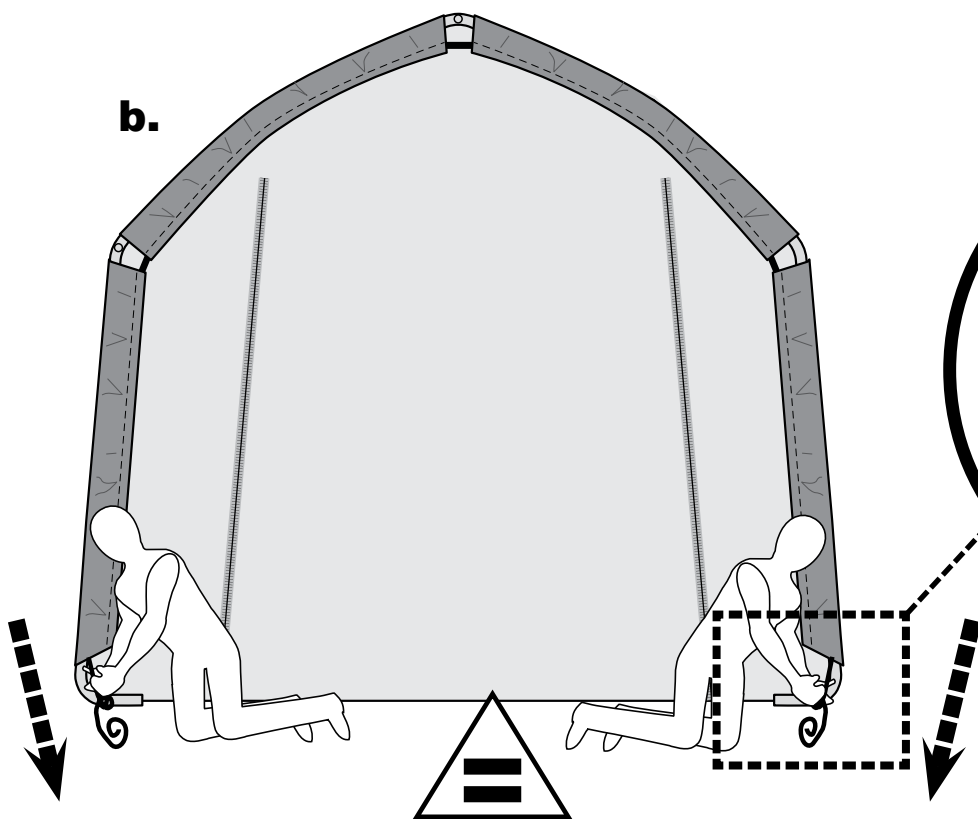

12.

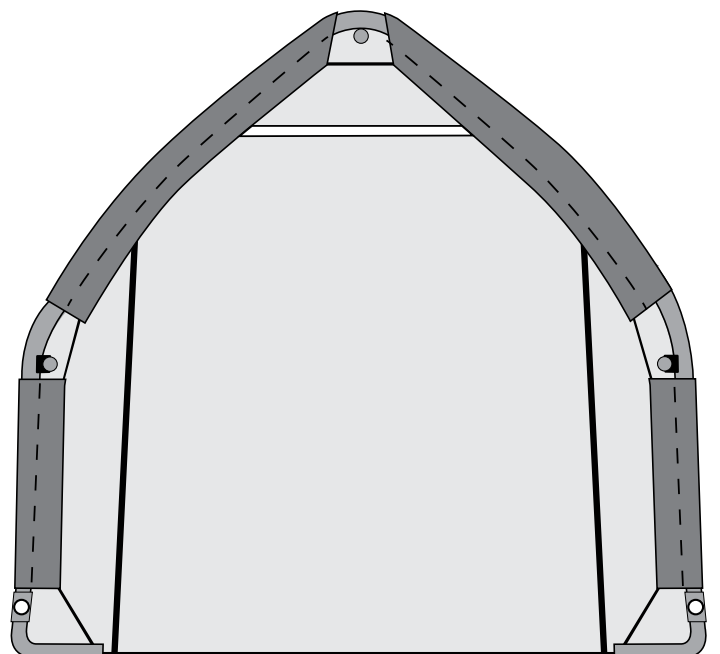
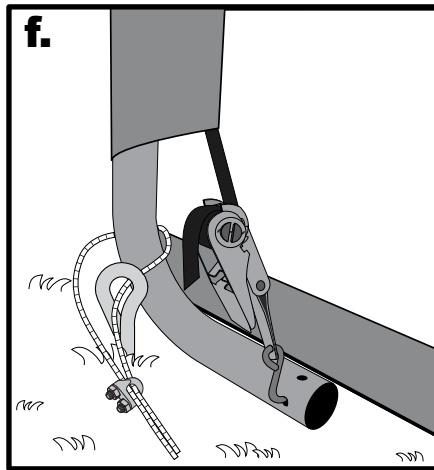
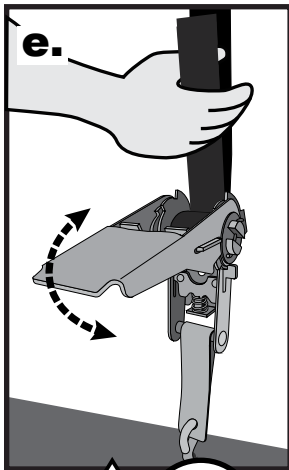
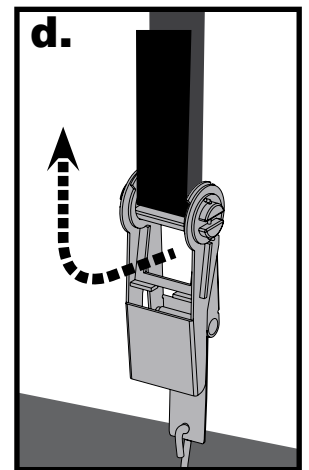
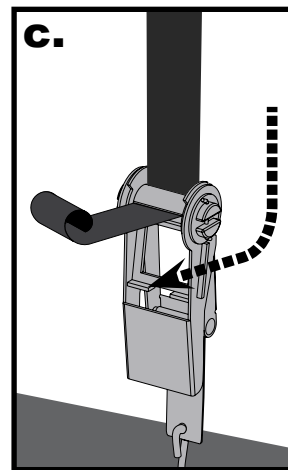
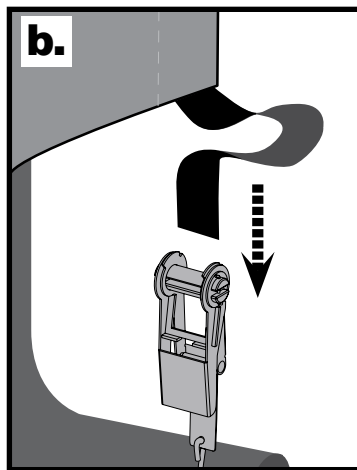
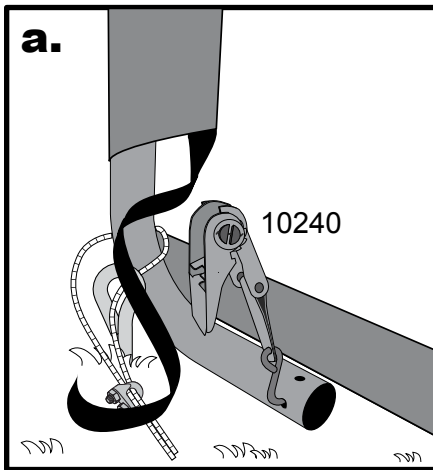
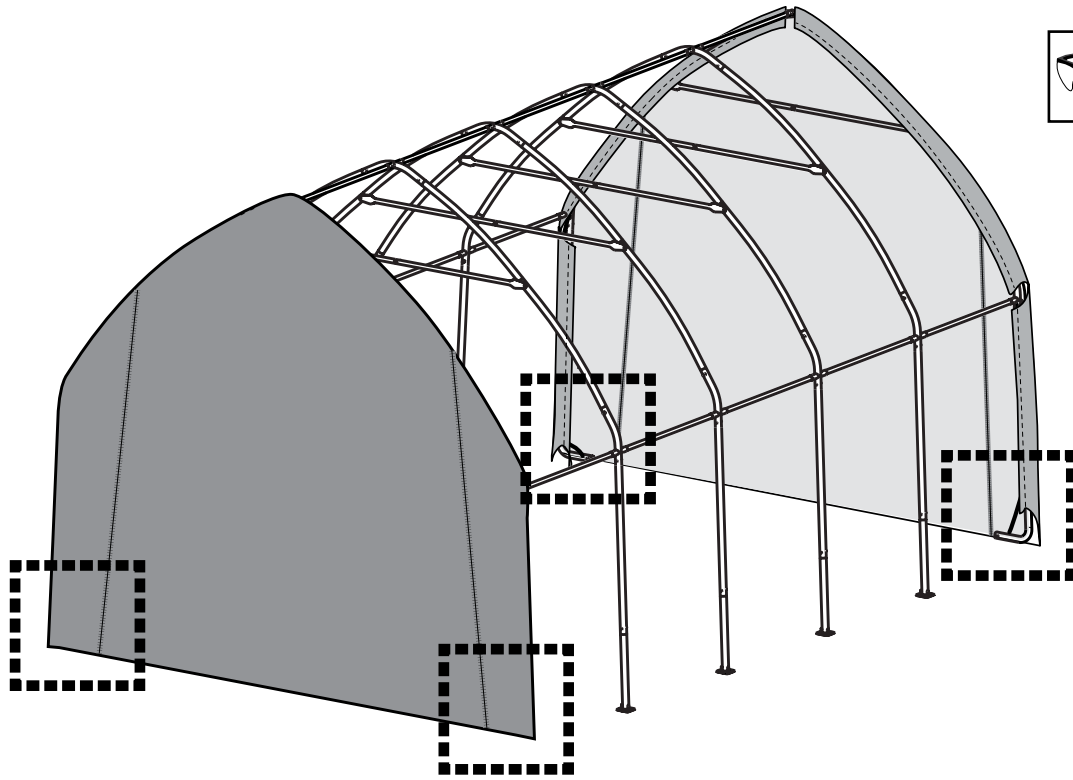
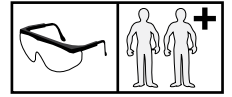

13.



a.

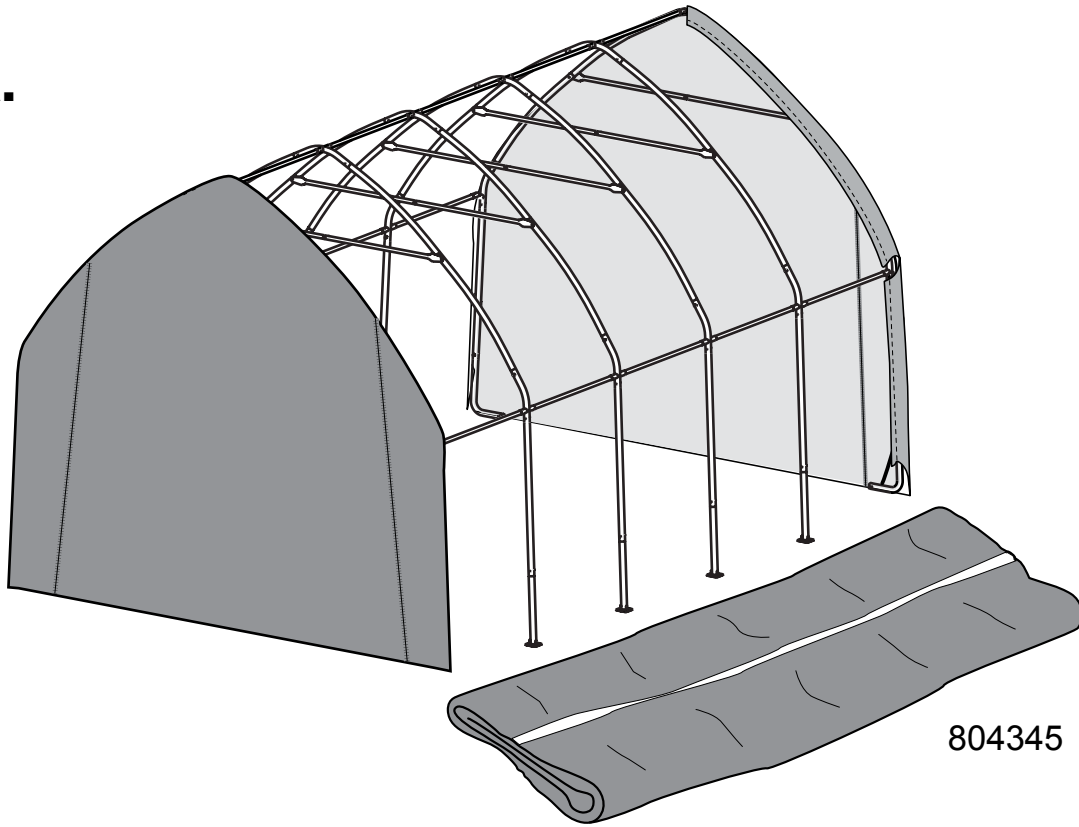

804345

b.

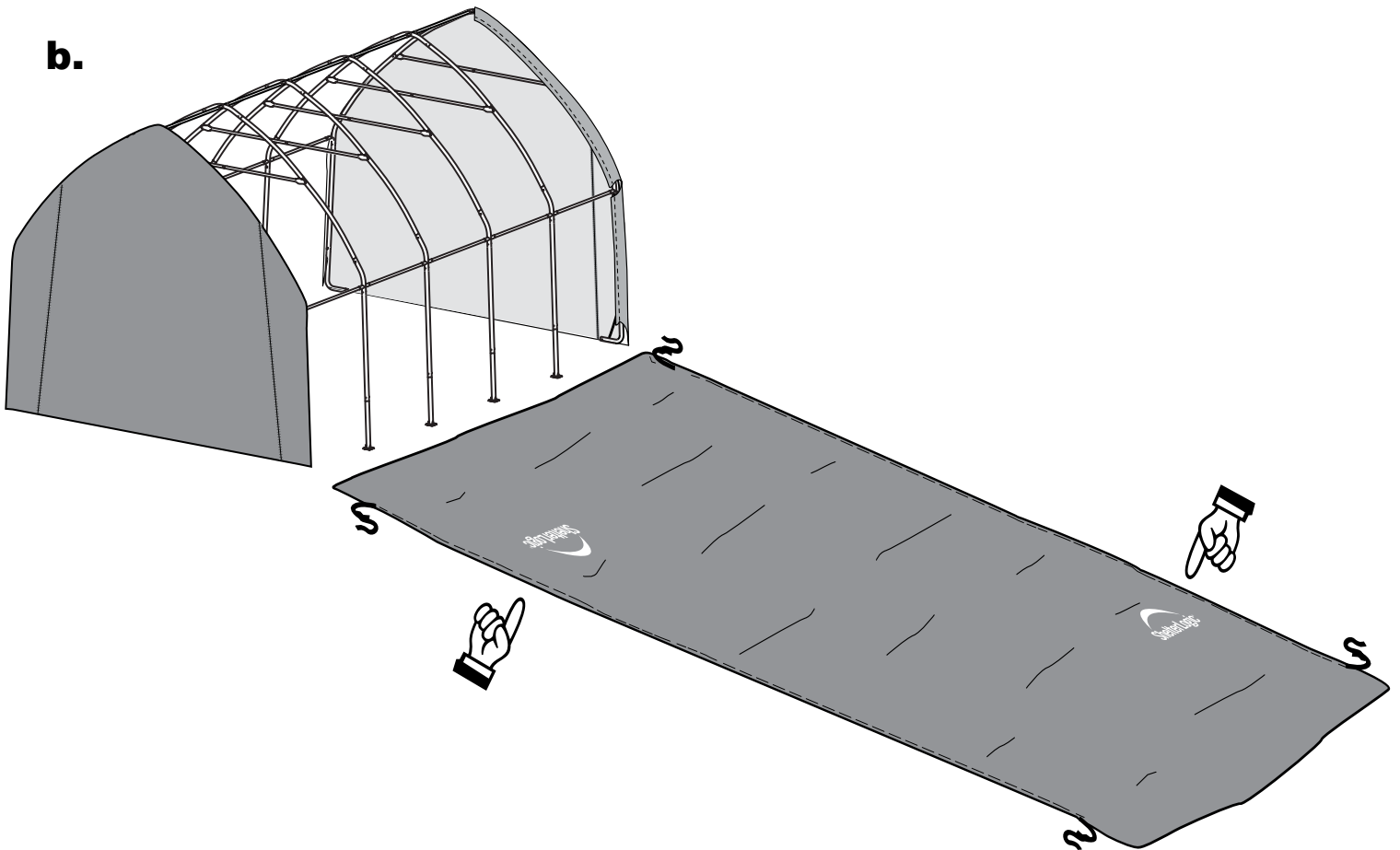

13. c.

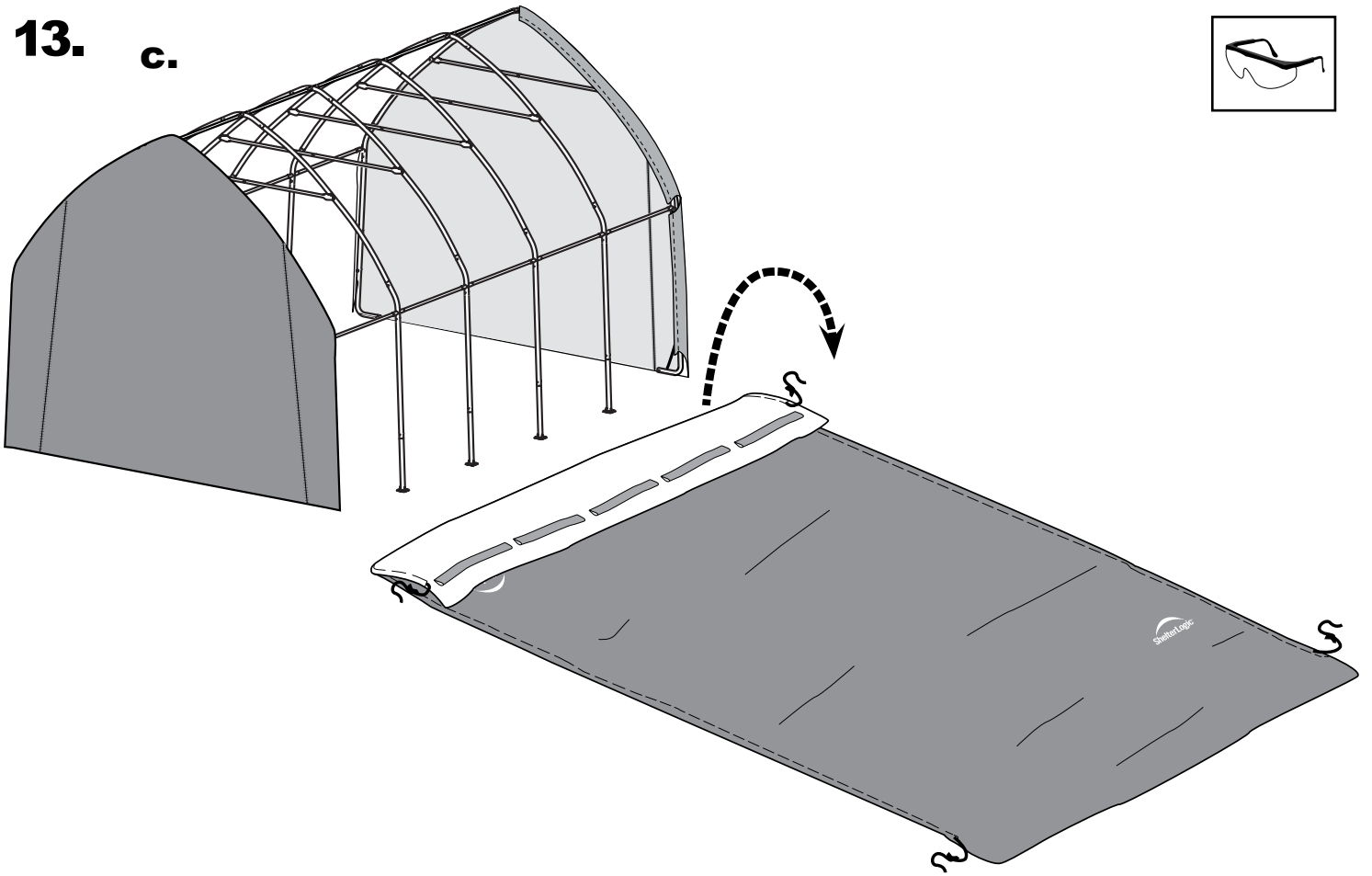

14.

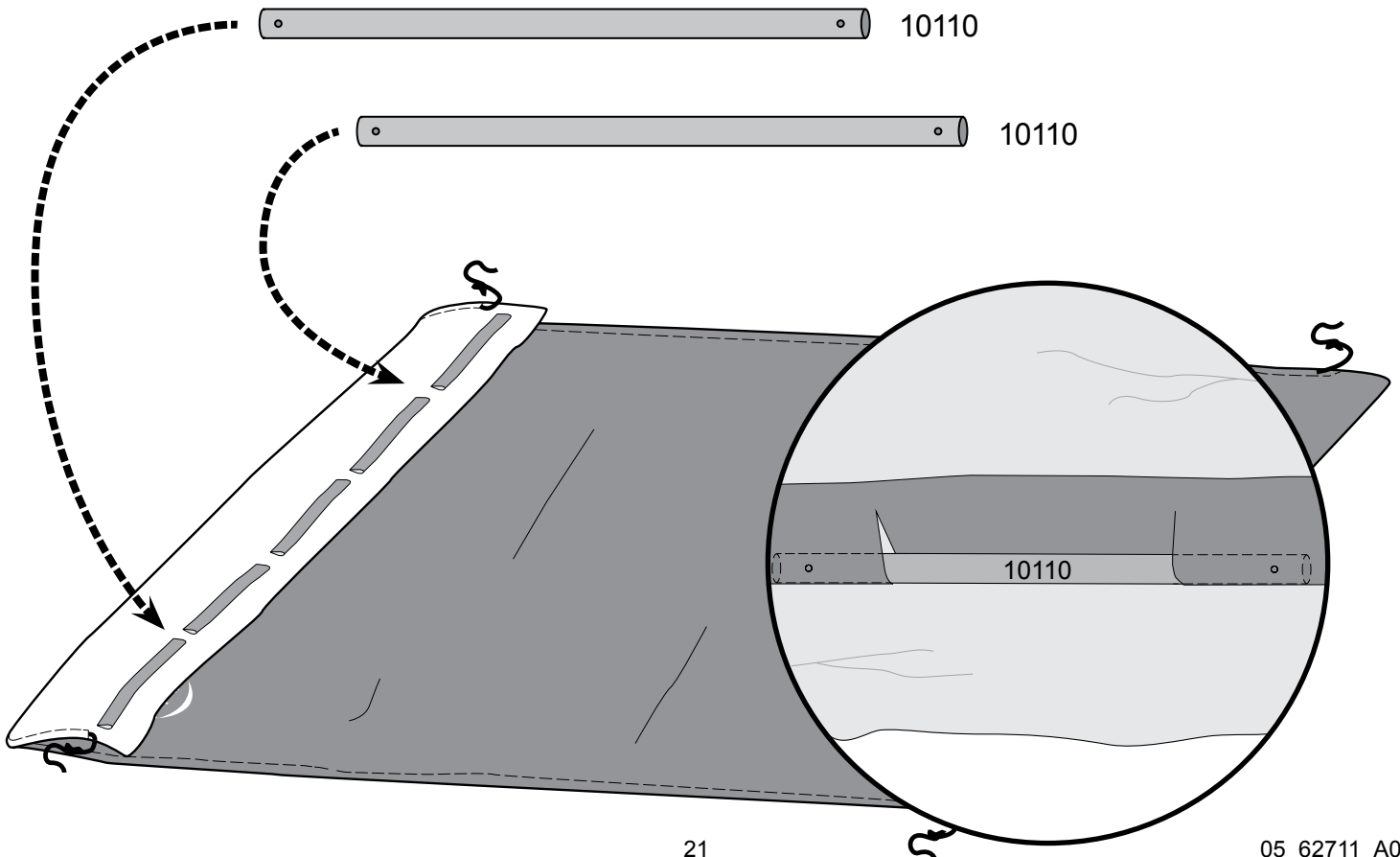

15.

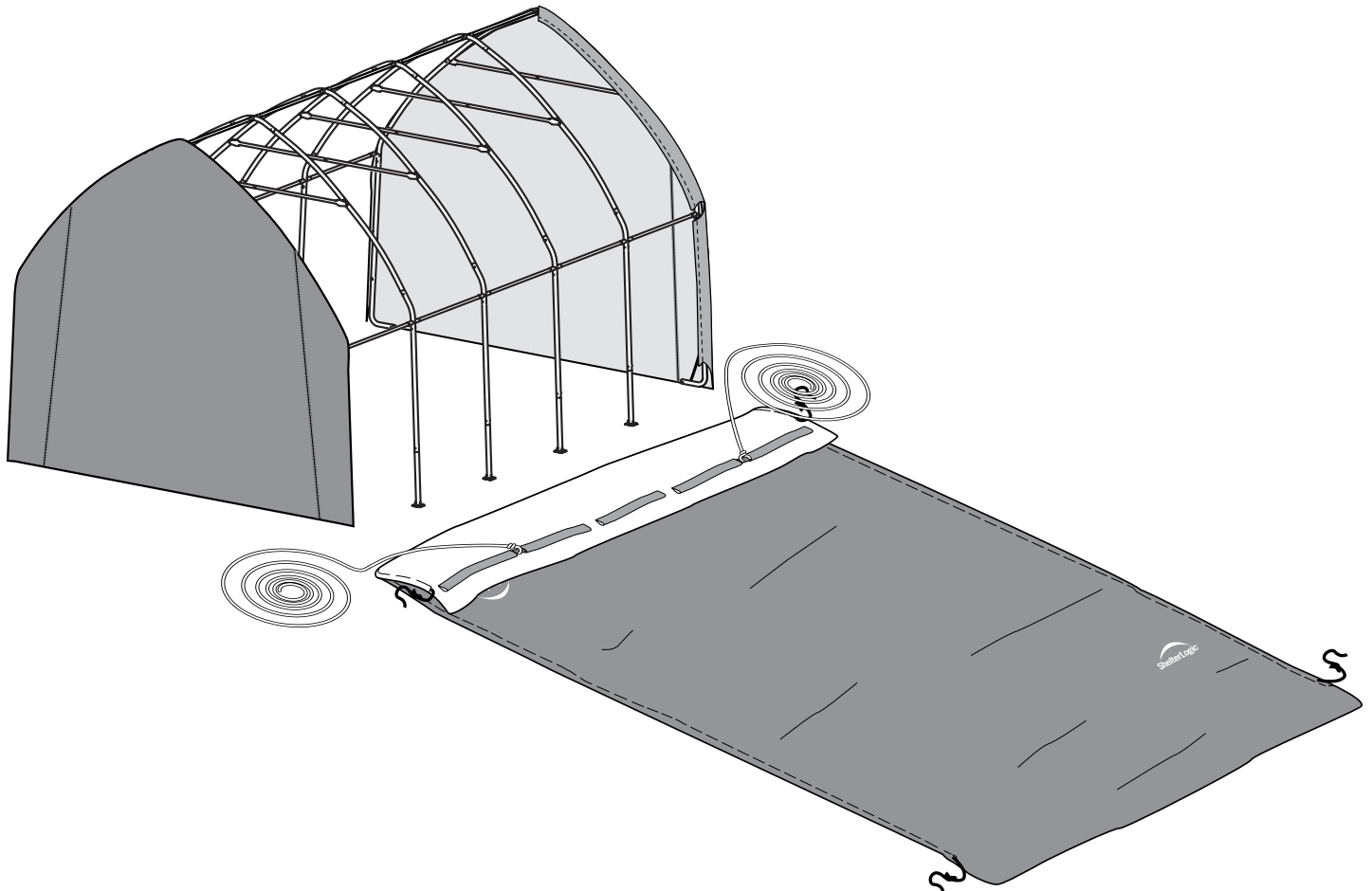
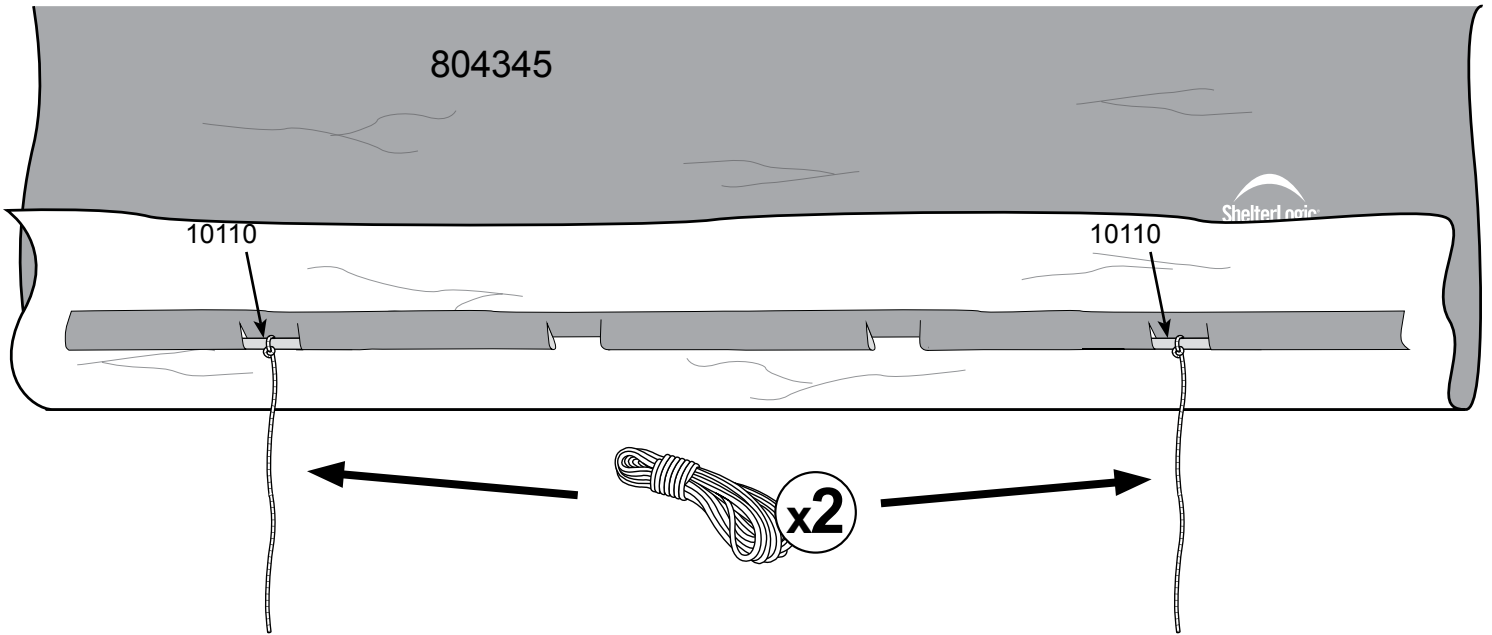
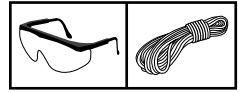

16.

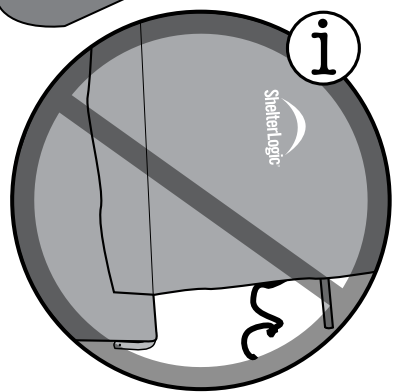
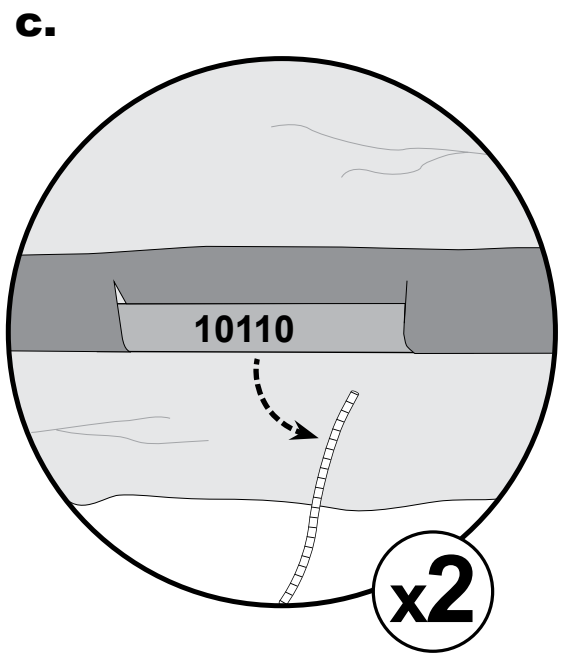
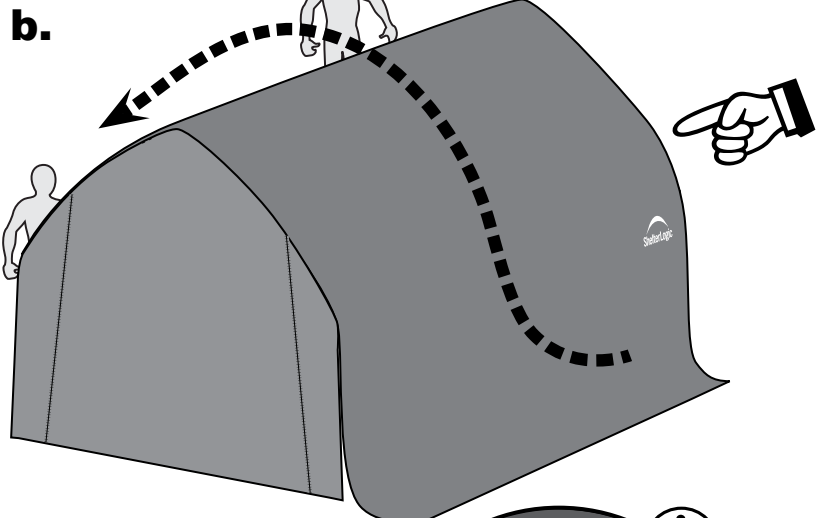
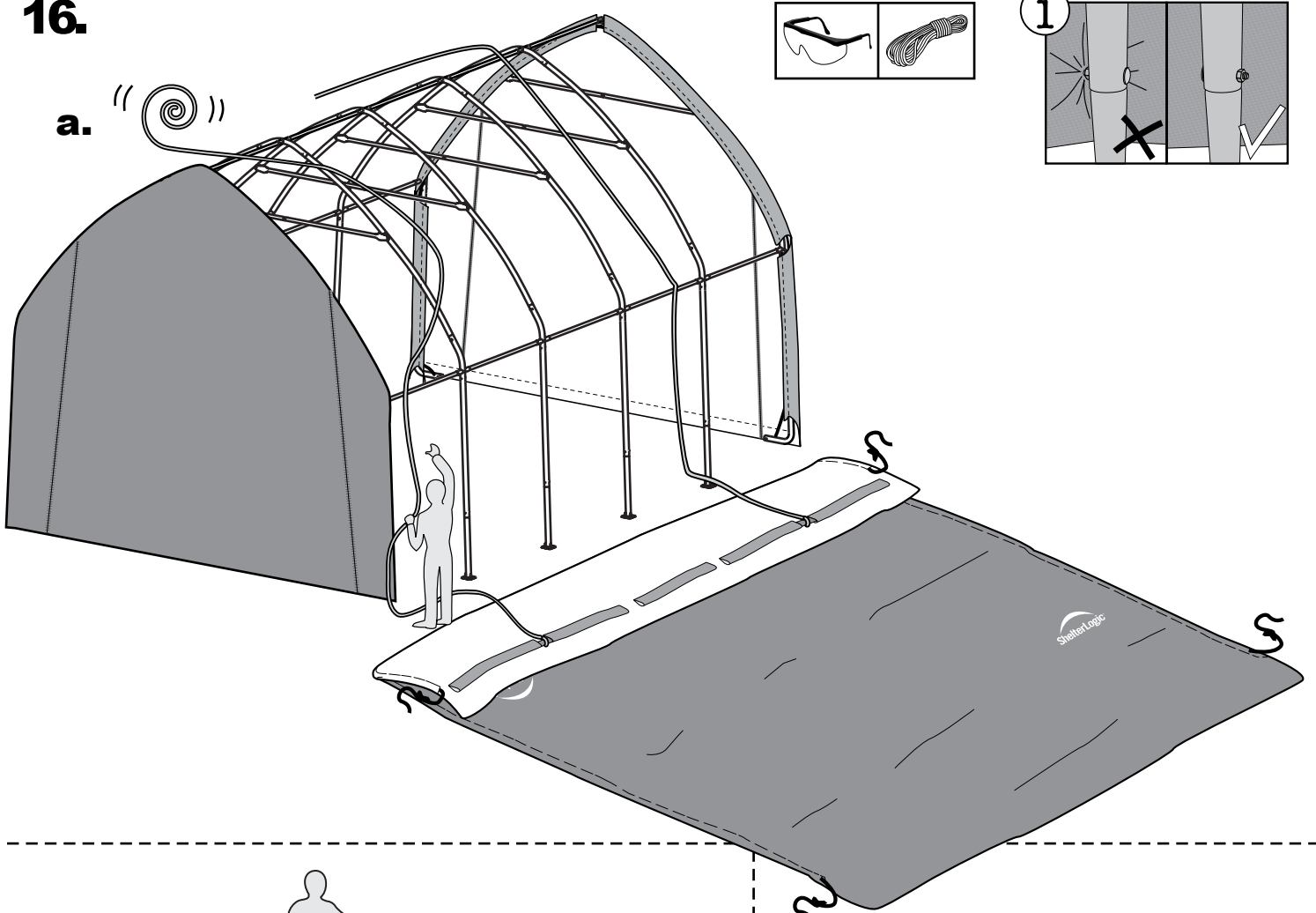

17.

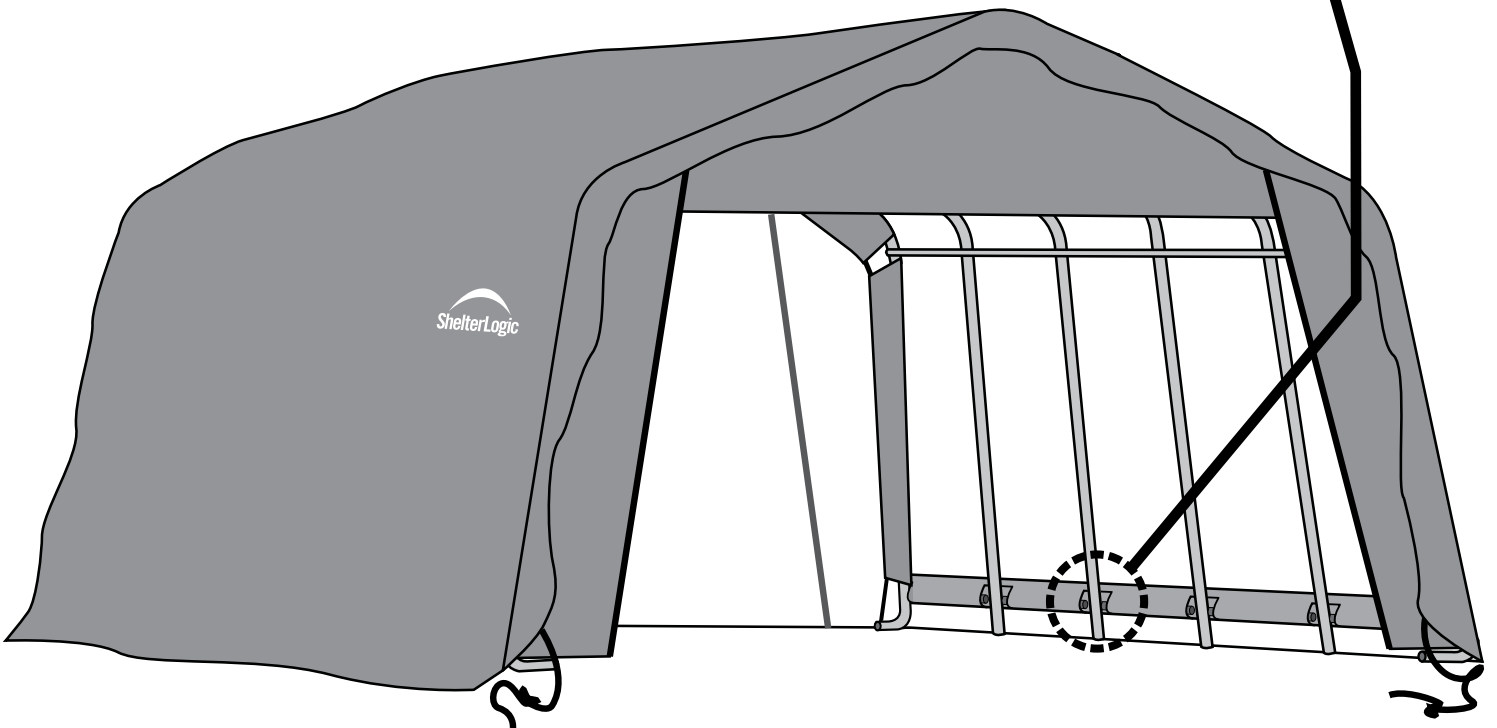
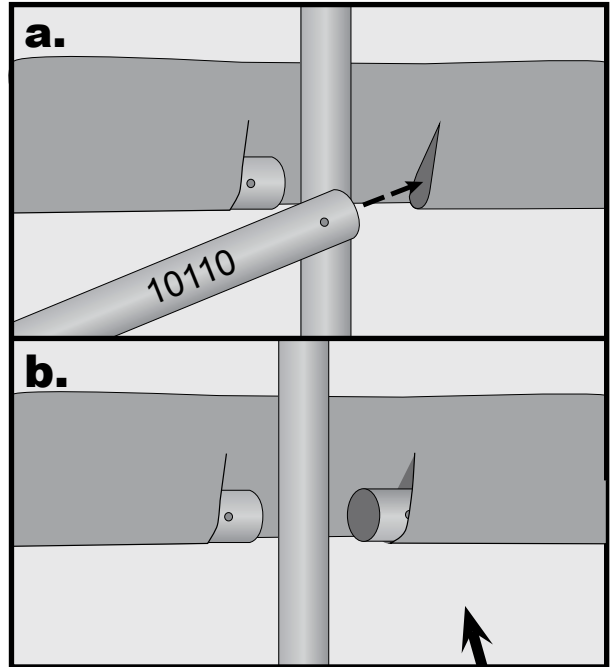
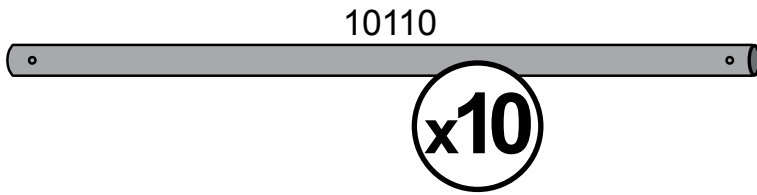
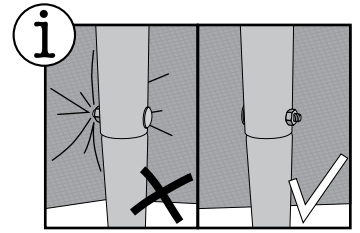
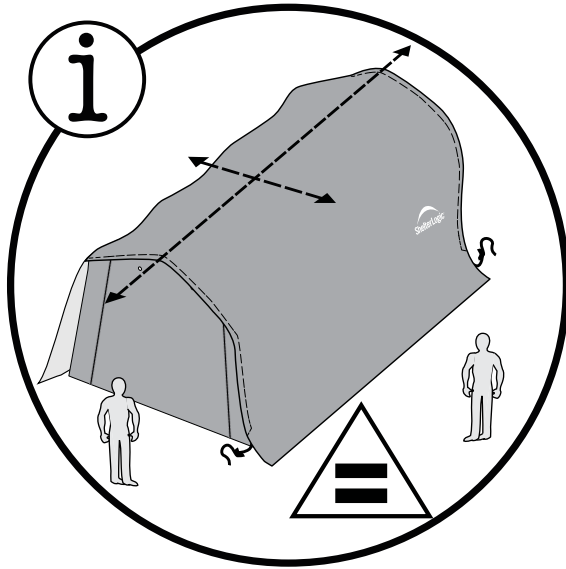

18.

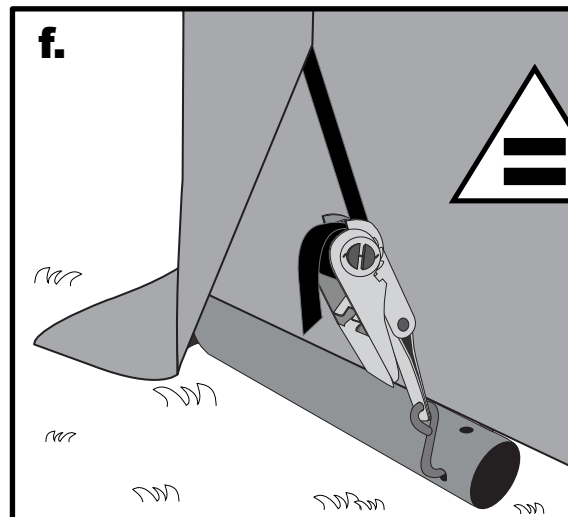
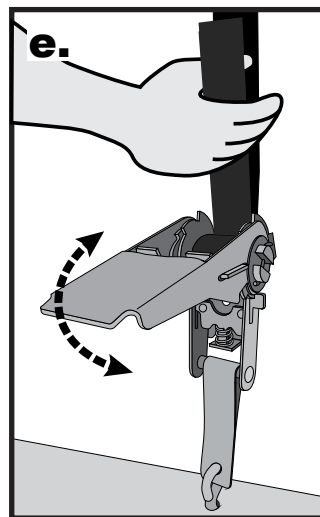
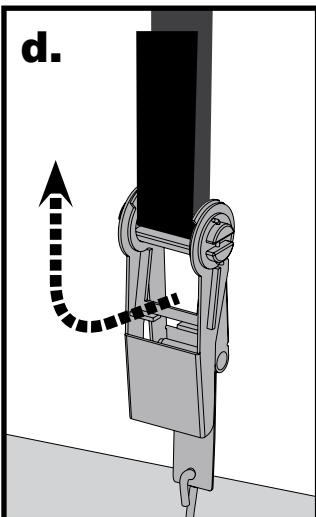
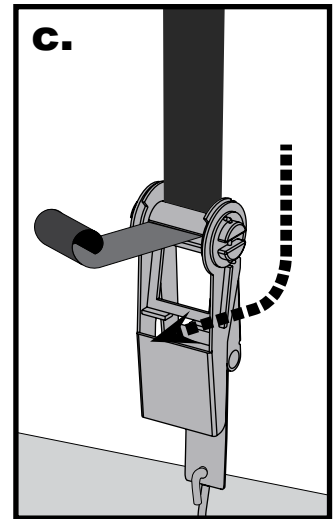
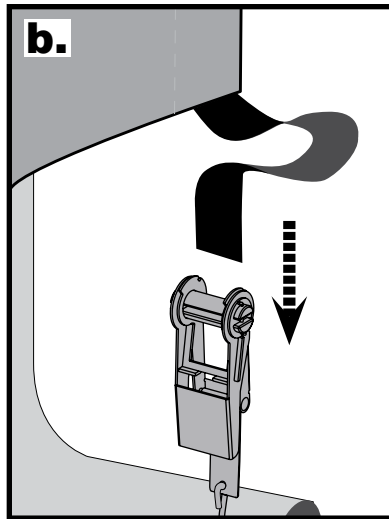
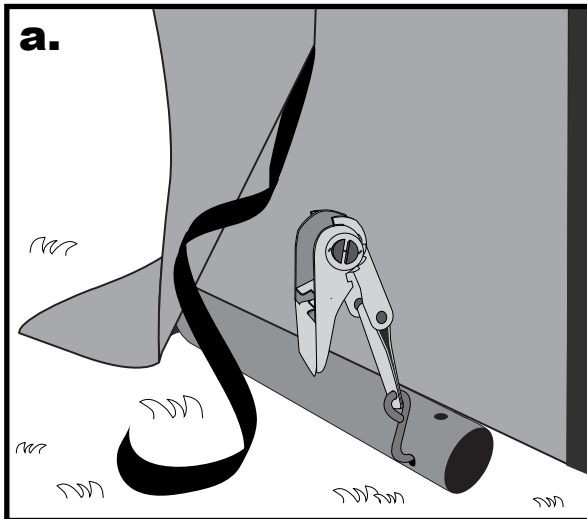
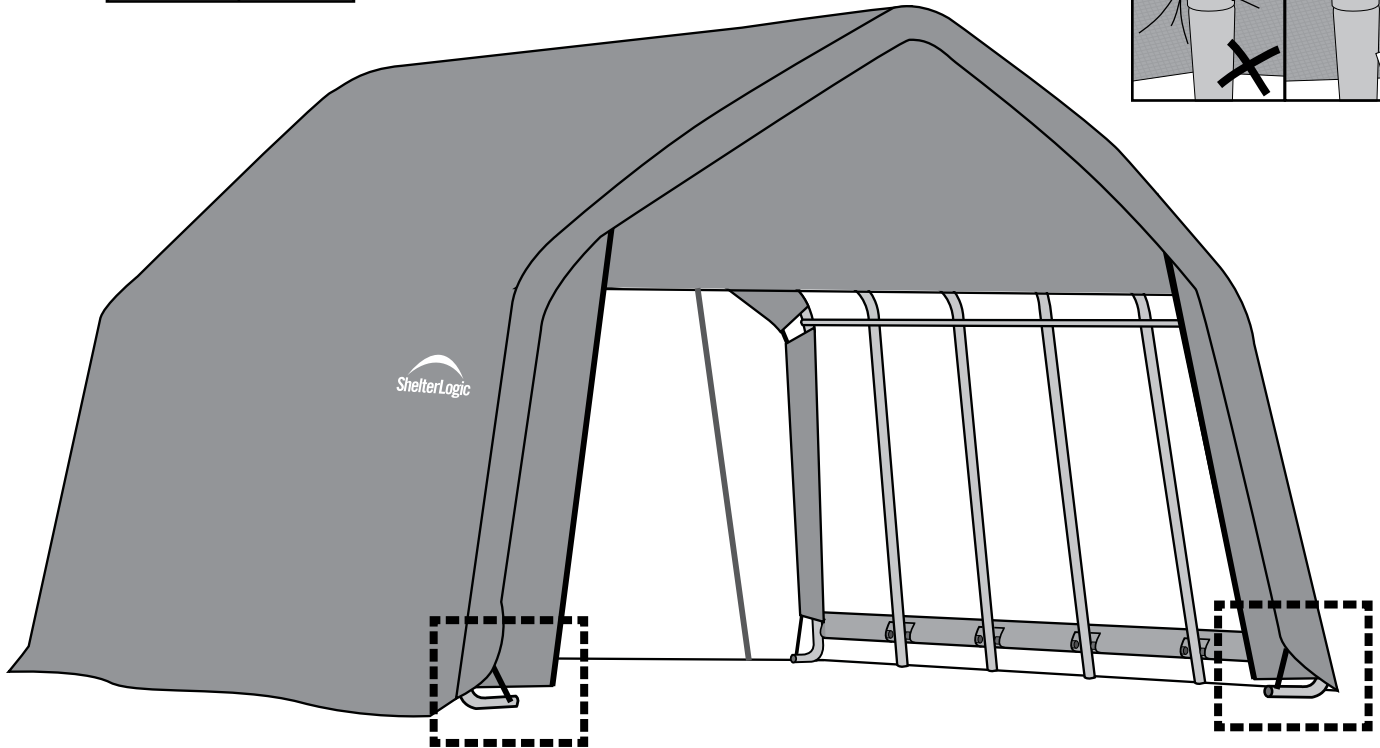
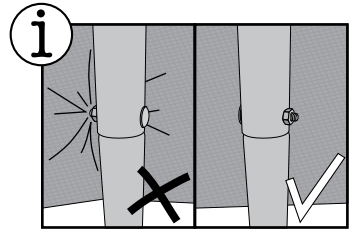
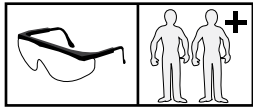

19.

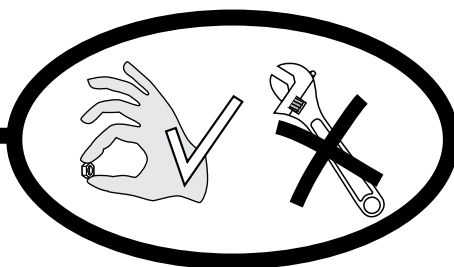
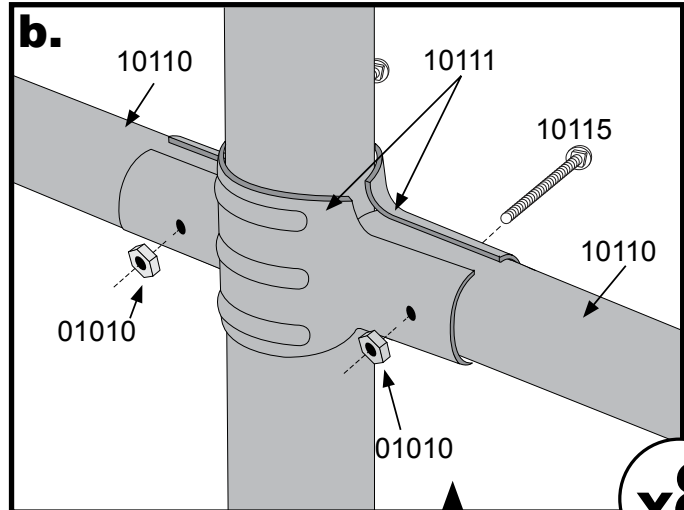
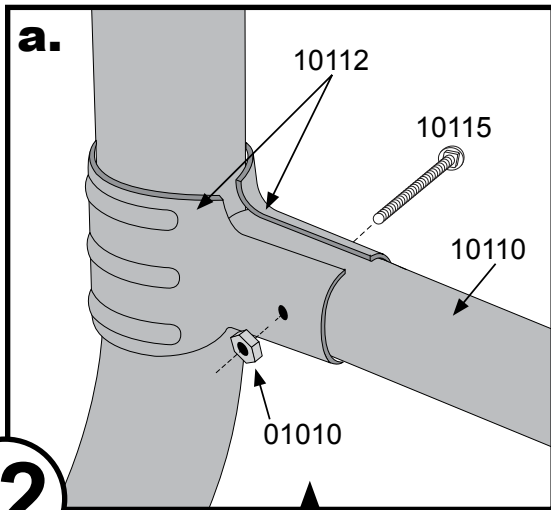
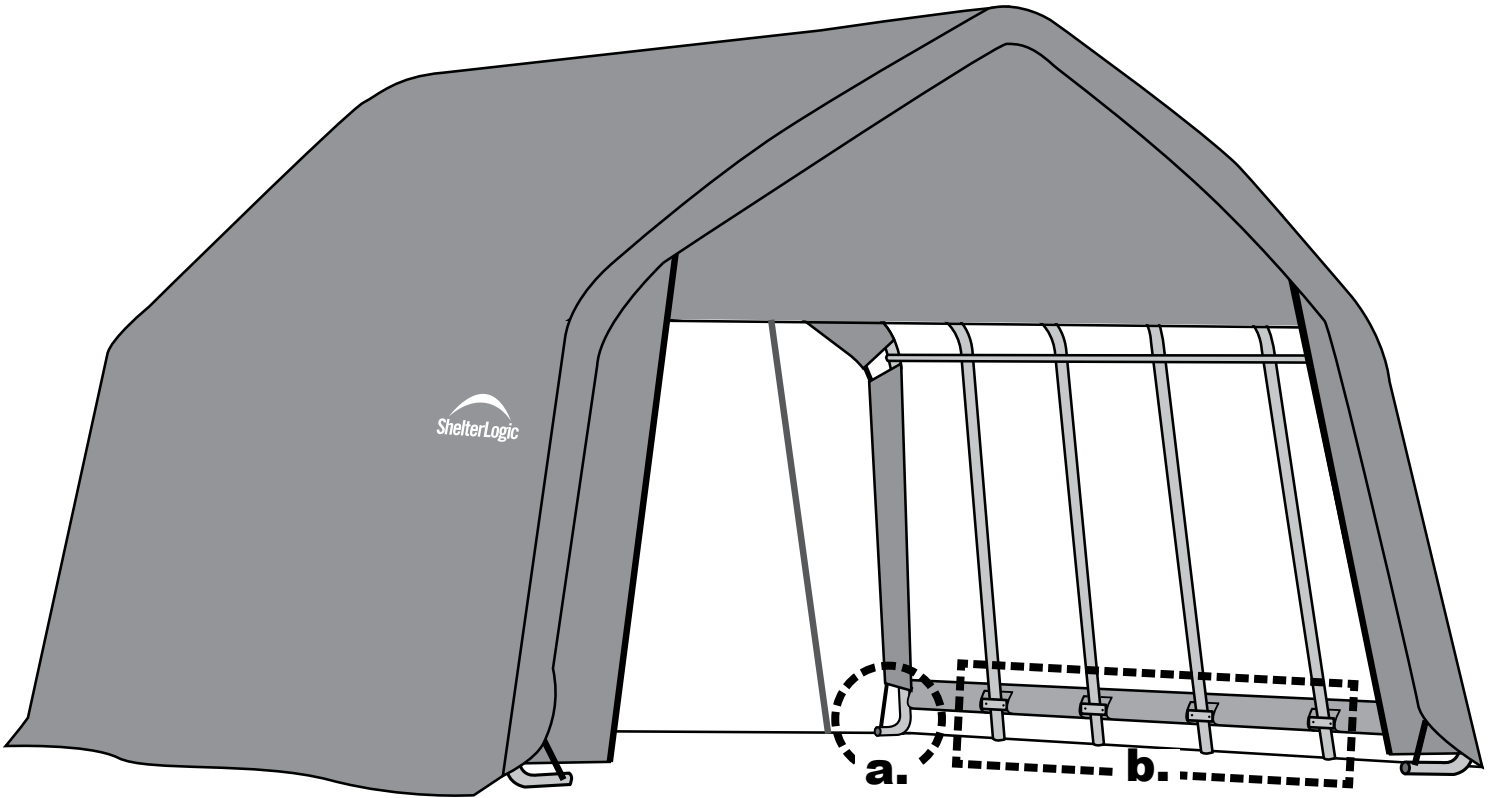
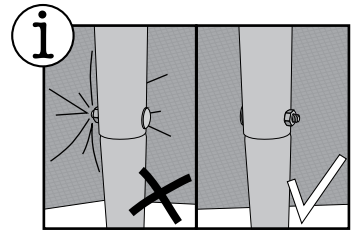
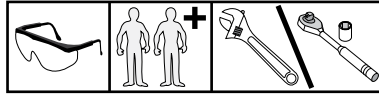

20.

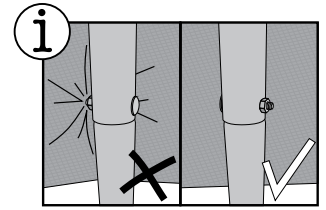
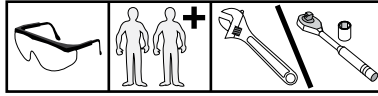

Kontrollera och dra åt locket varje månad för att säkerställa lång livslängd .

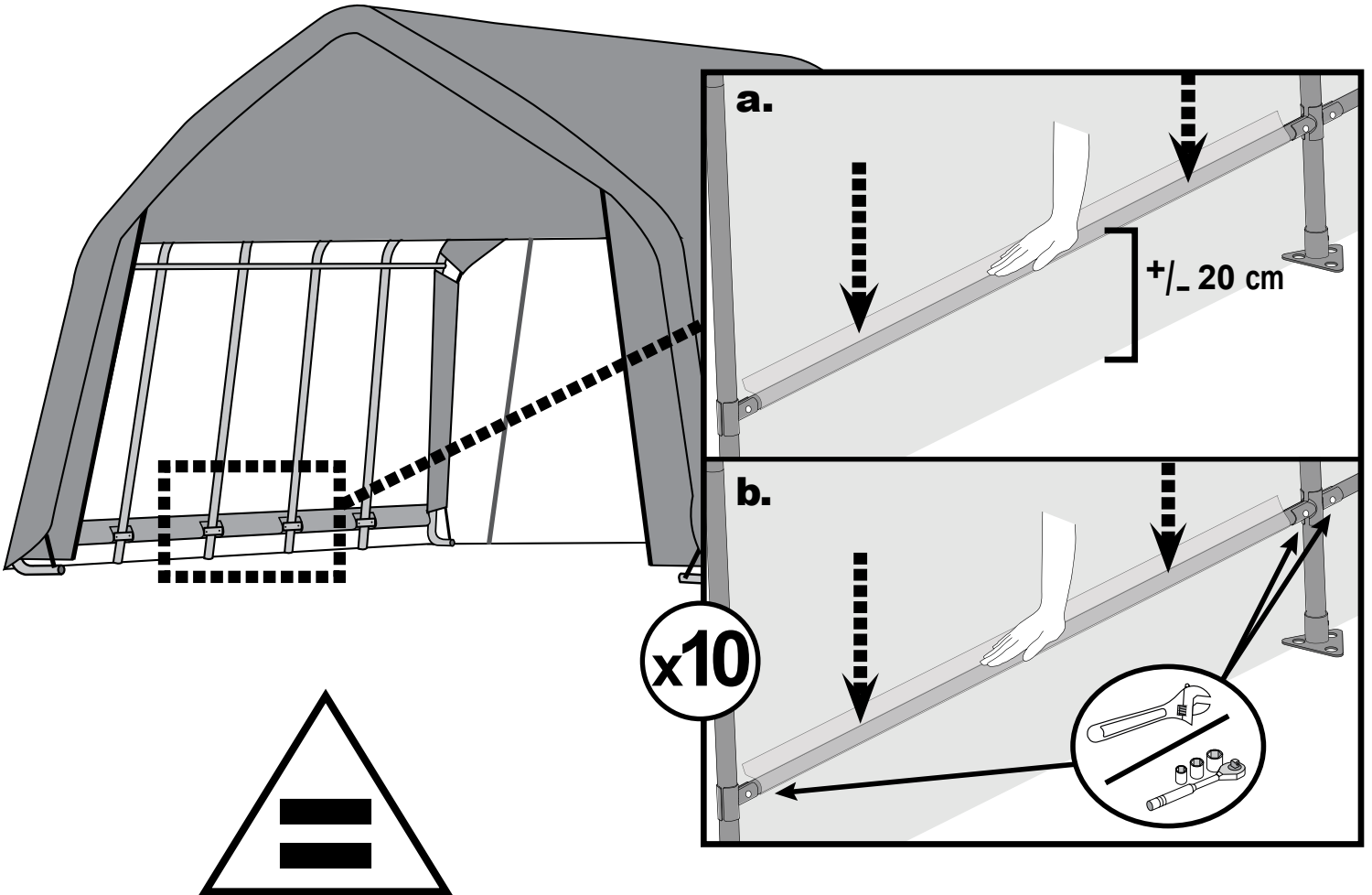

Dra åt samtidigt midjan 1 & 2 sedan midja 3 och 4

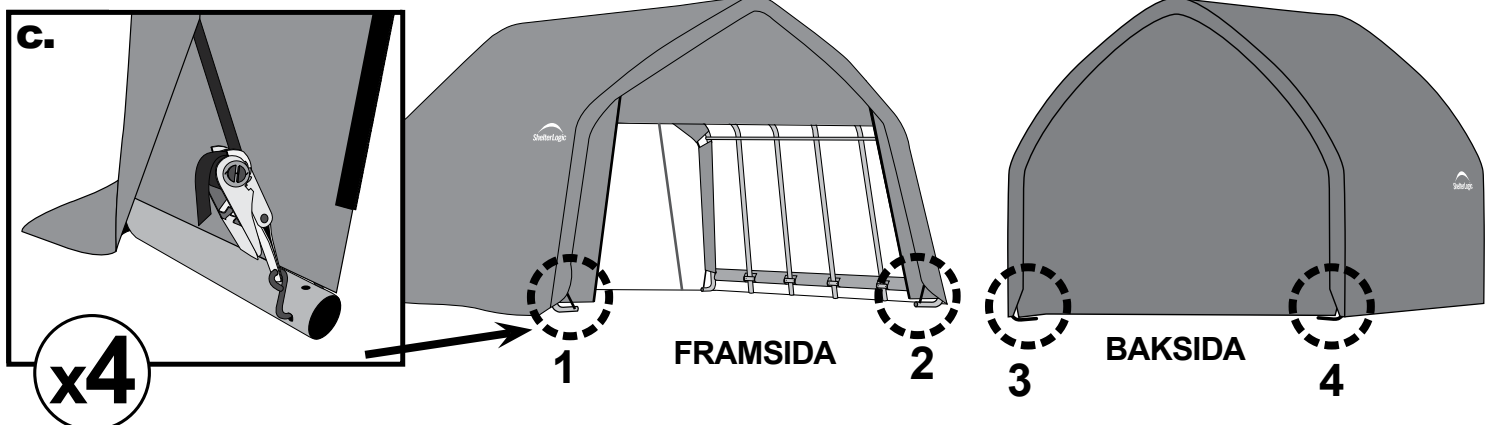

21.

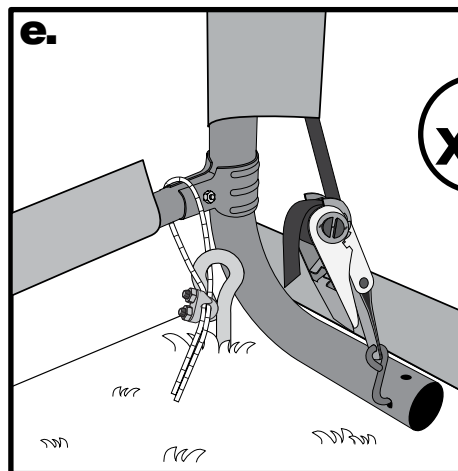
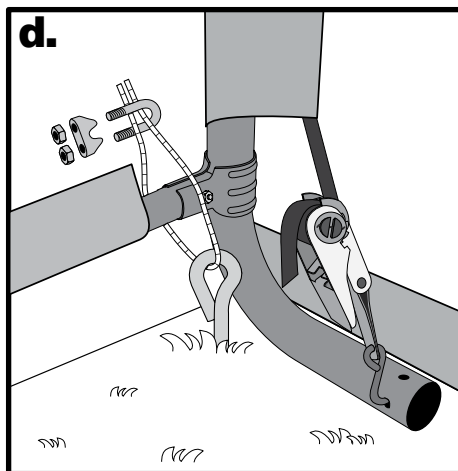
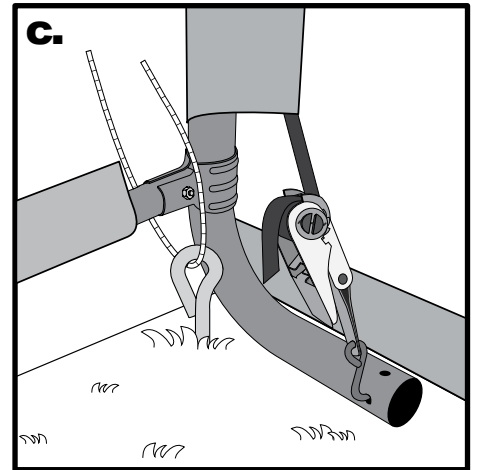
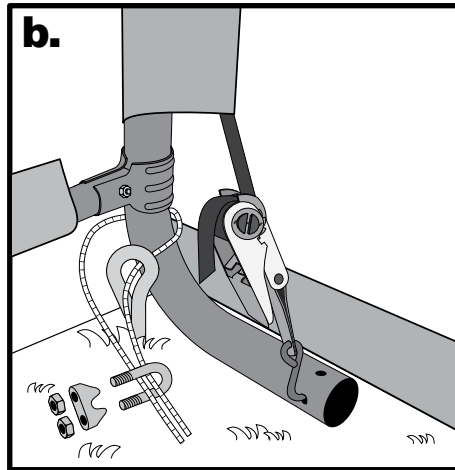
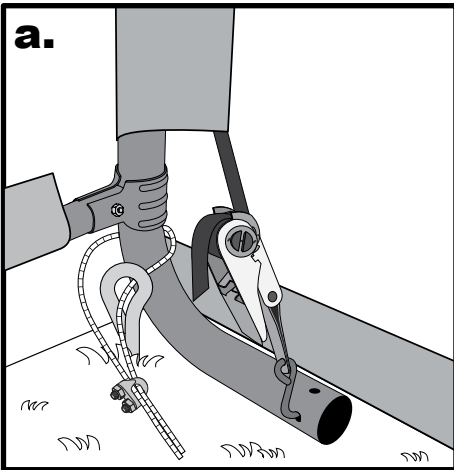
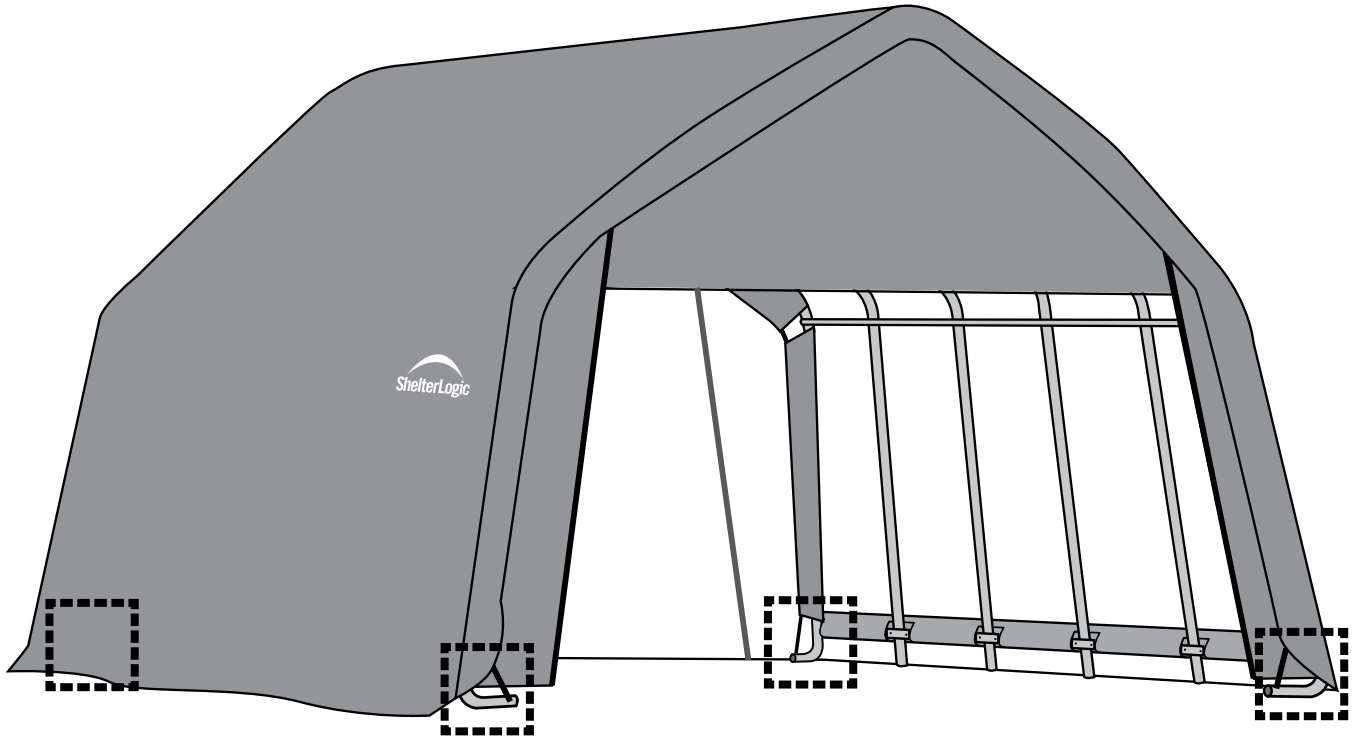
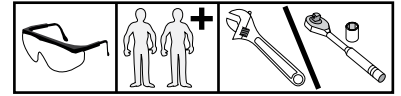

x4

Roll-Up Door Kit

Description of Parts:	Quantity
"S" Hooks	2
Plugs for Poles	2
Butterfly Cleat	1
Screws for Cleat	2
Philips Head Screwdriver Bit	1
Pipe, Plain End	1
Pipes, Swedged End	5
30,5 m Rope	1

NOTE: Review all parts included in the kit.

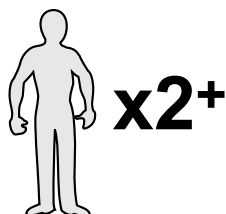
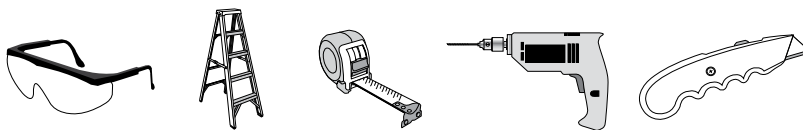

1. ASSEMBLE PIPES FOR BOTTOM POCKET OF DOOR.

A. Measure width of door between the zippers to determine size.

B. Slide pipes into one another to assemble.

NOTE: Fill pipe with sand for added weight and insert plugs.

C. Slide pipe into pocket at bottom of door.

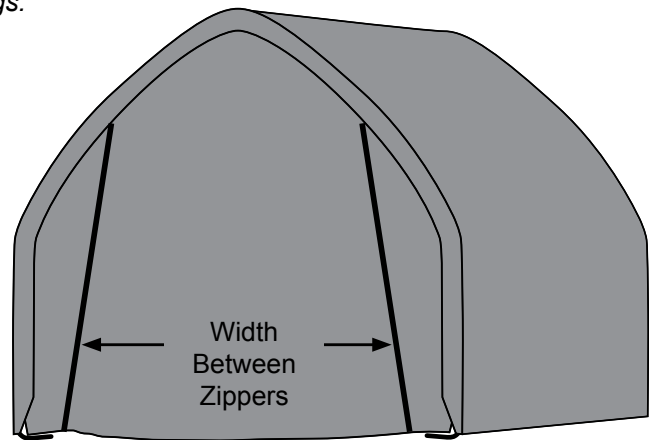

2. ATTACH BUTTERFLY CLEAT TO INSIDE OF SHELTER FRAME

Attach butterfly cleat with screws to second vertical rib, about 20 cm down from cross rail on either side.

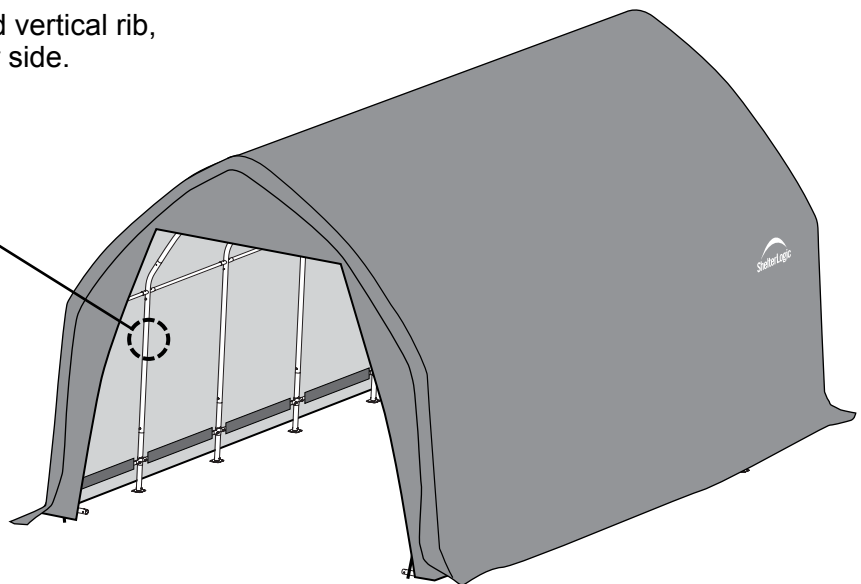
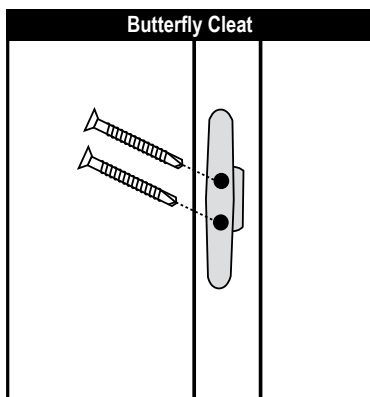

3. ATTACH ROPE ENDS TO OUTSIDE OF SHELTER COVER

A. Cut a small slit/hole, approximately 45,7 cm in from zipper, on the outside of the cover, just above the webbing rope. Do this on both sides.

B. Tie a knot around the cover webbing through the hole in the cover.

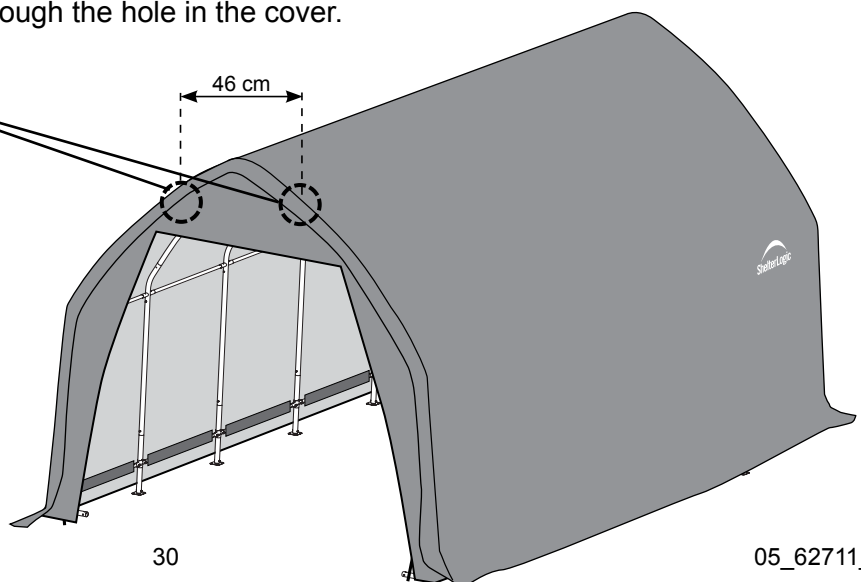
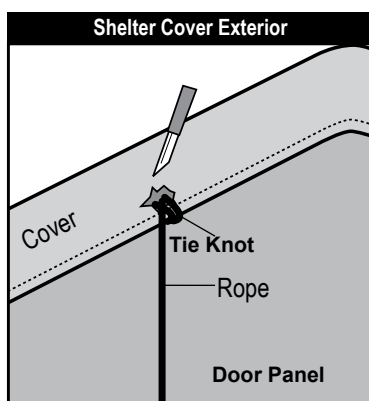

4. ATTACH "S" HOOKS AND ROPE TO THE INSIDE OF THE DOOR PANEL

A. Cut 2 more slits inside the shelter on door above the webbing. Hang each pulley here.

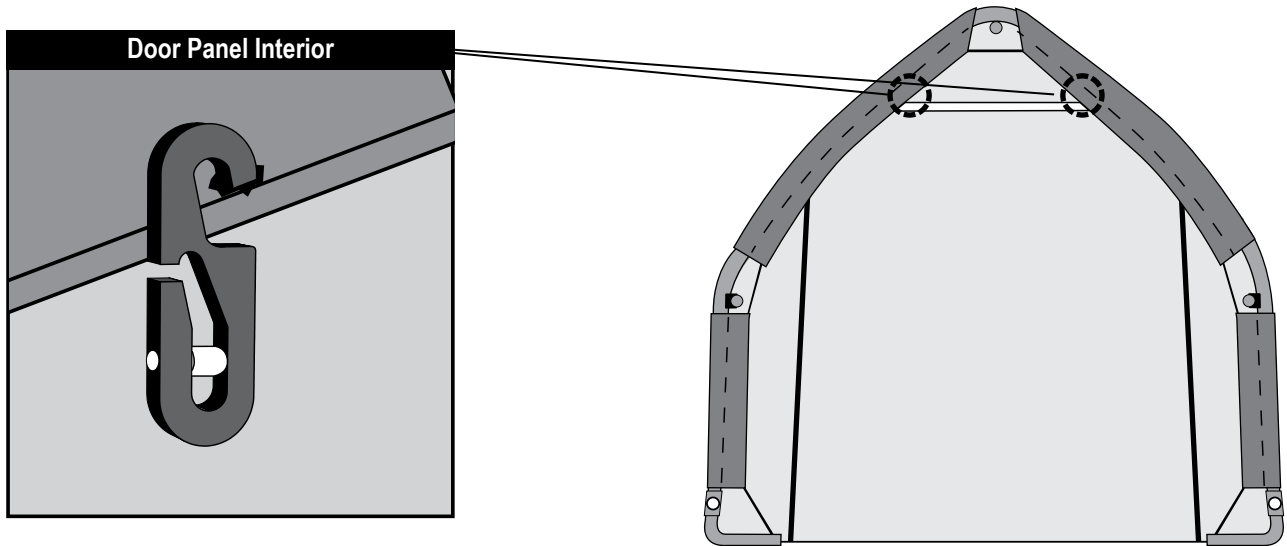

B. Pass the rope from the knot down under the door and back up to the first pulley. Hook each rope on each pulley. Do this on both sides.

C. On the opposite side of the cleat, bring one rope across top of the door to the other pulley and pass it through that pulley. You should have 2 pieces of rope hanging on the same side of the shelter as the cleat.

D. Hand start to roll up the door holding the 2 ropes together. The door will start to roll up around the pipe from the bottom as you pull the ropes, similar to a window shade. Secure the ropes to cleat at preferred height.

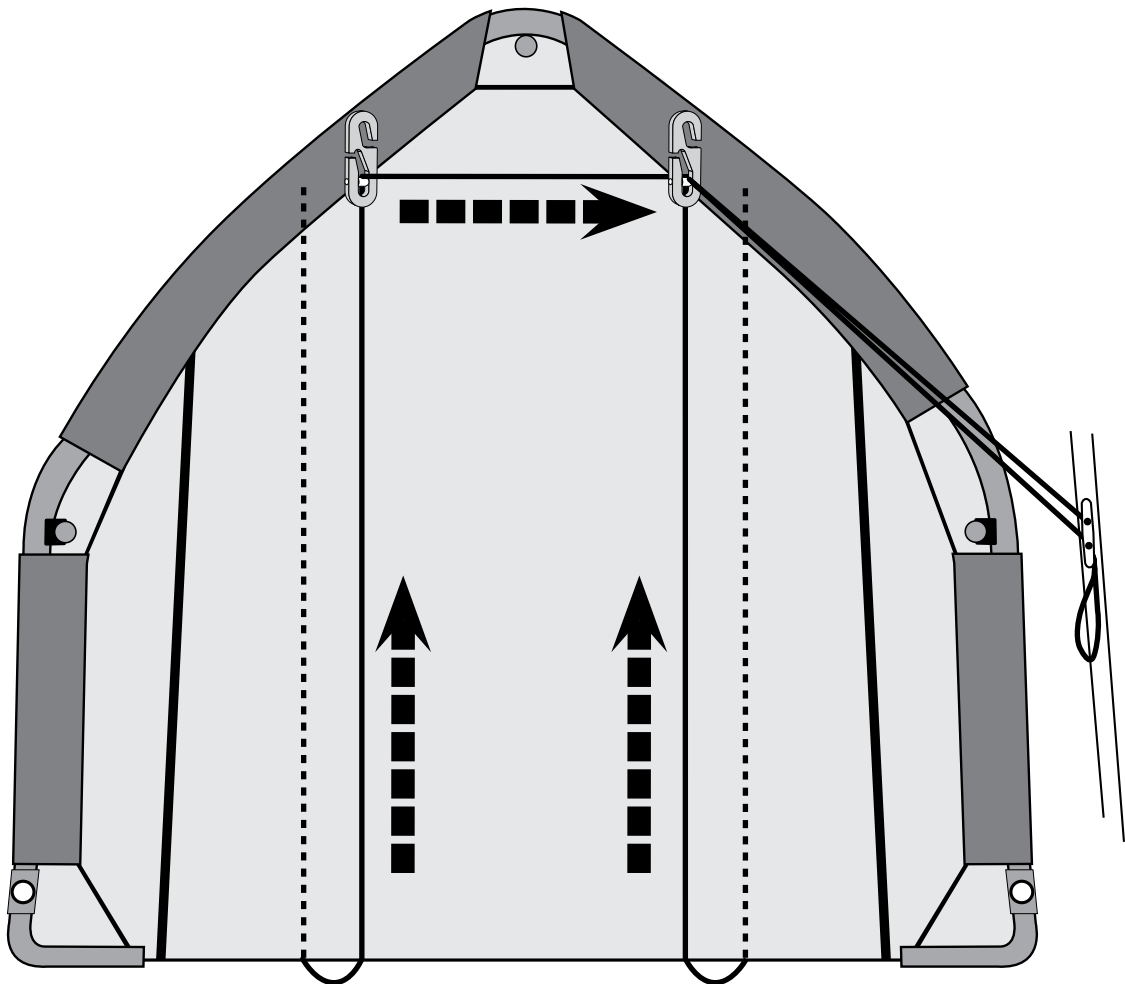

INSIDE VIEW OF DOOR PANEL