



# ASSEMBLY INSTRUCTIONS

Para español, vea la página 2.  
Pour français, voyez la page 3.



## 11' x 11' OUTDOOR STORAGE SHED

Lifetime sheds are designed to be strong and durable. We strive to make assembly as easy as possible without compromising quality. If you get stuck, we have tools to help:

- **Build a Foundation**  
Construct a level surface before you start (see page 6 for instructions).
- **Recruit Friends and Family**  
Assembly should take 3 people about 4–6 hours to complete.

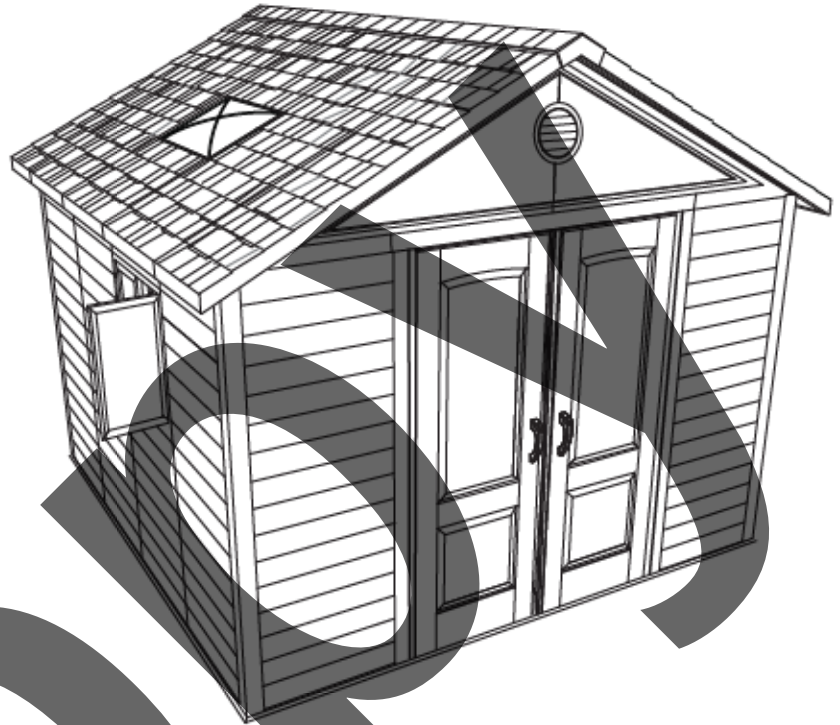

### TOOLS REQUIRED



### TABLE OF CONTENTS

Icon Legend.....	4
Warnings & Notices.....	5
Platform Construction.....	6
Truss Assembly.....	11
Gable Assembly.....	16
Door Assembly.....	18
Domed Skylight Assembly.....	25
Floor Assembly.....	30
Wall Assembly.....	33
Truss Installation.....	38
Shelving Installation.....	45
Parts Identifier.....	47
Door & Gable Installation.....	58
Trim Installation.....	67
Roof Assembly.....	70
Window Installation.....	78
Pegboard Strip Installation.....	85
Door Alignment.....	88
Shed Anchoring.....	91
Cleaning & Care.....	95
Registration.....	96
Warranty.....	97

### NEED HELP? TALK TO US!

Lifetime's Shed Assembly Experts offer quick responses and great customer service.

Call: 1-800-225-3865  
7:00 am - 5:00 pm (Monday - Friday) MST  
and 9:00 am - 1:00 pm Saturday MST

Web: [www.lifetime.com/instructions](http://www.lifetime.com/instructions)  
Live Chat: [www.lifetime.com/instructions](http://www.lifetime.com/instructions)

MODEL# AND PRODUCT ID (you will need both when contacting us)  
Model Number: Product ID:  
6433

**LIFETIME**

# INSTRUCCIONES DE ENSAMBLAJE

For English, see page 1.

Pour français, voyez la page 3.



## COBERTIZO EXTERIOR DE 3,35 m x 3,35 m

Los cobertizos Lifetime® son diseñados para ser sólidos y durables. Nos esforzamos por hacer el ensamblaje lo más fácil posible sin comprometer la calidad. Si se atasque, tenemos las herramientas necesarias para ayudarle:

- **Construye una plataforma**  
Construye una plataforma nivel antes de comenzar.  
(vea la página 6 para las instrucciones)
- **Junte a sus amigos y a su familia**  
El montaje debe llevar 3 adultos unas 4-6 horas para completar.

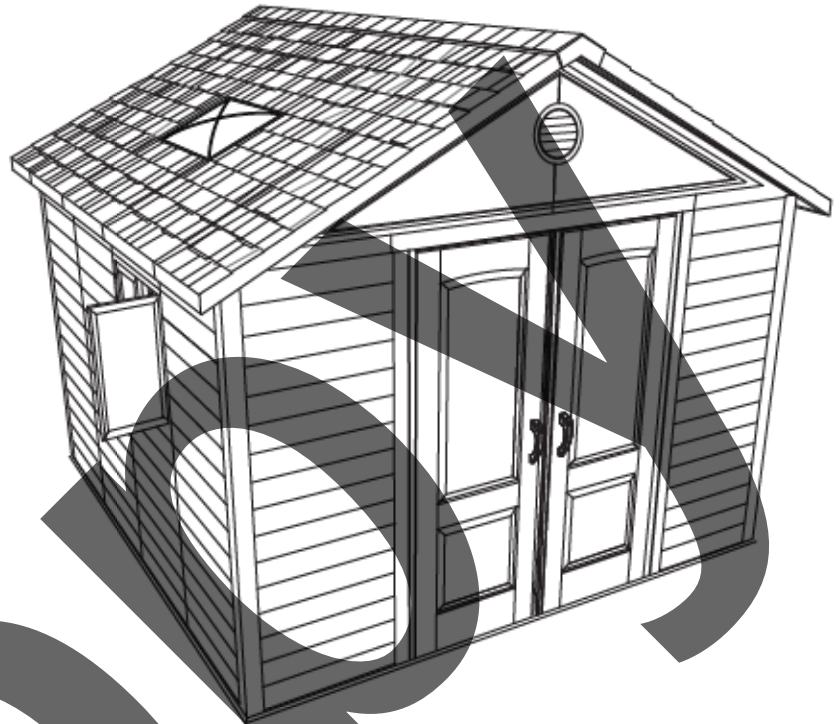

### INSTRUMENTAL REQUERIDO



### ÍNDICE

Leyenda de íconos.....	4
Advertencias & Noticias.....	5
Ensamblaje de la plataforma.....	6
Ensamblaje de los armazones.....	11
Ensamblaje de las fachadas.....	16
Ensamblaje de las puertas.....	18
Ensamblaje de los tragaluces.....	25
Ensamblaje del piso.....	30
Ensamblaje de los muros.....	33
Instalación de los armazones.....	38
Instalación de los estantes.....	45
Identificador de piezas.....	47
Instalación de las puertas.....	58
Instalación de las molduras.....	67
Ensamblaje del tejado.....	70
Instalación de las ventanas.....	78
Instalación de los organizadores.....	85
Alineación de las puertas.....	88
Anclaje del cobertizo.....	91
Limpieza & Cuidado.....	95
Registro.....	96
Garantía.....	98

**¿NECESITA AYUDA? ¡LLÁMENOS!**

Los Expertos de ensamblaje Lifetime® ofrecen respuestas rápidas y servicio valorado.

Llame al **1.800.225.3865**  
0700 – 1700 lunes hasta viernes (HNR)  
y 0900 – 1300 sábado (HNR)

Web: [www.lifetime.com/instructions](http://www.lifetime.com/instructions)  
Live Chat: [www.lifetime.com/instructions](http://www.lifetime.com/instructions)

MODELO E ID DEL PRODUCTO (necesitará los dos al contactarnos)

Número de modelo: ID del producto:

**6433**

**LIFETIME**

# INSTRUCTIONS DE L'ASSEMBLAGE

For English, see page 1.

Para español, vea la página 2.



## ABRI EXTÉRIEUR DE 3,35 m x 3,35 m

Les abris Lifetime® sont conçus pour être solide et durable. Nous nous efforçons de rendre l'assemblage aussi facile que possible sans compromettre la qualité. Si vous êtes coincé, nous avons les outils nécessaires pour vous aider :

- **Construisez une Plate-forme**

Construisez une plate-forme horizontale avant de commencer.

(voyez la page 6 pour les instructions)

- **Rassemblez vos Amis et votre Famille**

L'assemblage devrait prendre 3 adultes à peut près 4 – 6 heures pour achever.

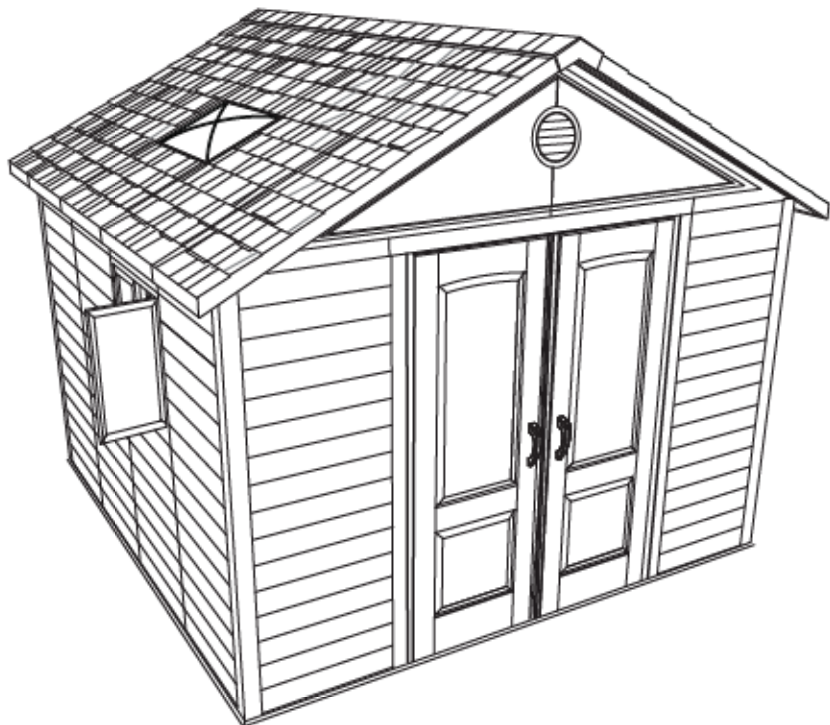

### OUTILS REQUIS



### SOMMAIRE

Légende des icônes.....	4
Avertissements & Notifications.....	5
Assemblage de la plate-forme.....	6
Assemblage des fermes.....	11
Assemblage des toits à pignon.....	16
Assemblage des portes.....	18
Assemblage des lucarnes.....	25
Assemblage du plancher.....	30
Assemblage des murs.....	33
Instalación des fermes.....	38
Installation des étagères.....	45
Identificateur de pièces.....	47
Installation des portes.....	58
Installation des moulures.....	67
Assemblage du toit.....	70
Installation des fenêtres.....	78
installation des organisateurs.....	85
Alignement des portes.....	88
L'ancrage de l'abri.....	91
Nettoyage & Entretien.....	95
Enregistrement.....	96
Garantie.....	99

### NÉCESSITEZ-VOUS DE L'AIDE ? PARLEZ-NOUS !

Nos experts d'assemblage Lifetime® offrent des réponses rapides et de service clientèle supérieure.

Appelez au **1.800.225.3865**  
0700–1700 lundi à vendredi (HNR)  
et 0900–1300 samedi (HNR)

web: [www.lifetime.com/instructions](http://www.lifetime.com/instructions)  
tchat: [www.lifetime.com/instructions](http://www.lifetime.com/instructions)

MODÈLE ET ID DE PRODUIT (vous nécessitez les deux lorsque vous nous contactez)  
Número de modèle : ID du produit :  
**6433**



## ICON LEGEND / LEYENDA DE ÍCONOS / LÉGENDE DES ICÔNES



- Indicates special heed should be taken when reading.
- Indica que uno debe prestar atención al leer.
- Ceci indique que l'on doit faire attention à ce que vous lisez.



- Indicates the parts to be used for a section.
- Indica las piezas requeridas para una sección.
- Ceci indique les pièces requises pour une section.



- Indicates no parts required for a specific section.
- Indica que ninguna pieza es requerida para una sección específica.
- Ceci indique qu'il n'y a pas de pièces requises pour une section particulière.



- Indicates the hardware to be used for a section.
- Indica los elementos de fijación requeridos para una sección.
- Ceci indique les accessoires requis pour une section.



- Indicates no hardware required for a specific page.
- Indica que ningún elemento de fijación es requerido para una página específica.
- Ceci indique qu'il n'y a pas d'accessoires requis pour une page particulière.



- Indicates the tools to be used for a section.
- Indica las herramientas requeridas para una sección.
- Ceci indique les outils requis pour une section.



- Indicates to use/not to use an electric drill for a specific step.
- Indica usar/no usar un taladro eléctrico para un paso específico.
- Ceci indique utiliser/n'utiliser pas de perceuse électrique pour une étape particulière.



## WARNINGS & NOTICES / ADVERTENCIAS & NOTIFICACIONES / AVERTISSEMENTS & NOTIFICATIONS

### English:

- **Failure to follow these warnings may result in serious injury or property damage and will void warranty.**
- To ensure safety, do not attempt to assemble this product without following the instructions carefully.
- Consult all local building codes to verify if the shed requires a building permit.
- Verify the foundation is completely level before assembling the shed.
- Be aware that plastic pieces can be damaged by overtightening the screws. To avoid damage, we strongly recommend the use of a drill with a low torque setting. A #2 Phillips screwdriver may also be used.
- Three capable adults are required for assembly.
- All who participate in the assembly process should wear safety glasses throughout the assembly.
- If using a ladder during assembly, use extreme caution.
- We strongly recommend anchoring your shed when it is finished. See instructions later in this manual.
- In heavy snowfall areas, we recommend removing snow from the roof.
- Do not use or store hot objects near the product.
- Proper and complete assembly are essential to reduce the risk of accident or injury.
- You will need to anchor your shed to your platform. The last section, Shed Anchoring, in this manual shows the hardware you'll need to complete the anchoring. You can find the hardware at your local hardware store.
- **Most injuries are caused by misuse and/or not following instructions. Use caution when using this product.**

### español:

- **El incumplimiento de seguir estas advertencias puede resultar en lesiones graves o daño a la propiedad y anulará la garantía.**
- Para asegurar la seguridad, no intente armar este producto sin seguir detenidamente las instrucciones.
- Consulte todos los códigos locales de construcción para averiguar si necesita un permiso de construcción.
- Verifique que la plataforma es completamente nivel antes de montar el cobertizo.
- Es posible endañar las piezas de plástico por apretar los tornillos. Para evitar dañar el plástico, recomendamos que use un taladro eléctrico de baja potencia. Se puede usar también un destornillador de punta Phillips #2.
- Tres adultos competentes son requeridos para ensamblar el cobertizo.
- Todos los que participan en el ensamblaje del cobertizo deben llevar gafas de seguridad a lo largo del ensamblaje.
- Si utiliza una escalera durante el ensamble, tenga cuidado extremo.
- Nosotros recomendamos encarecidamente que ancle el cobertizo al completarlo. Vea las instrucciones más adelante en este manual.
- En las áreas de nevadas fuertes, recomendamos que quite la nieve del tejado.
- No use ni almacene objetos calientes en el cobertizo.
- El armado propio y completo son esenciales para reducir el riesgo de accidentes y lesiones.
- Es preciso anclar el cobertizo a la plataforma. La última sección, Anclaje del cobertizo, en este manual muestra los elementos de fijación que necesitará para finalizar el anclaje. Se compran estos elementos a su ferretería del barrio.
- **La mayoría de las lesiones son causadas por el uso erróneo y/o el incumplimiento de seguir las instrucciones. Tenga cuidado al usar este cobertizo.**

### français :

- **La non-respect de ces avertissements peut entraîner en conséquence des blessures sérieuses ou dommage à la propriété et annulera la garantie.**
- Pour assurer votre sécurité, n'attendez pas de monter cet élément sans suivre attentivement les instructions.
- Consultez tous les codes de bâtiment locaux pour vérifier si l'abri extérieur exige d'un permis de construire.
- Vérifiez que la plate-forme est complètement plate avant d'assembler l'abri.
- Il est possible endommager les pièces en plastique par serrer les vis excessivement. Pour éviter endommager le plastique, nous recommandons vivement l'usage d'une perceuse électrique de faible puissance. Vous pouvez aussi utiliser une Tournevis cruciforme #2.
- Trois adultes capables sont requis pour monter cet élément.
- Tous les personnes qui participent dans l'assemblage doivent porter des lunettes de sécurité tout le long de l'assemblage.
- Si vous utilisez une échelle pendant le montage, utilisez-la avec prudence.
- Nous recommandons vivement que vous anciez votre abri après avoir le complété. Voyez les instructions plus tard dans ce manuel.
- Dans les régions de grosses chutes de neige, nous recommandons que vous enleviez la neige du toit.
- N'utilisez pas ni conservez pas les objets chauds dans l'abri.
- Le montage propre et complète sont essentiels pour réduire le risque des hasards ou des blessures.
- Vous aurez besoin d'ancrer l'abri à votre plate-forme. La dernière section, Ancrage de l'abri, dans ce manuel montre les accessoires requis pour compléter l'ancrage. Vous pouvez acheter ces accessoires à votre quincaillerie de coin.
- **La plupart des blessures sont causées par l'abus et/ou par ne pas suivre les instructions. Faites attention lorsque vous utilisez cet abri.**

## PLATFORM CONSTRUCTION / CONSTRUCCIÓN DE LA PLATAFORMA / CONSTRUCTION DE LA PLATE-FORME



• You must provide a platform on which to assemble your shed. Proper building permit documentation may be required in your neighborhood. Consult all local building codes prior to assembling the shed. Before beginning assembly, you must pour or construct a platform. There are two types:

- Concrete
- Wood Frame

Select the type, but know the surface must be leveled and flat before installation. If the surface is not properly leveled and flat, the shed will not assemble correctly. Proper surface leveling will save you time in the long run, so please do not ignore this step. **We recommend a Concrete platform. It will be the most durable and long-lasting choice. The platform you choose must be built above ground in order to avoid water pooling inside the shed. All lumber must be rated for outdoor use!**



• Es preciso construir una plataforma sobre la cual usted debe ensamblar su cobertizo. Puede suceder que en su vecindario se requiera la documentación apropiada de un permiso de construcción. Consulte todos los códigos locales de construcción y los reglamentos de la ciudad y el municipio para asegurarse de que la construcción del cobertizo no requiere un permiso de construcción. Antes de comenzar el ensamblaje, es necesario verter o construir una plataforma. Hay dos clases:

- Concreto
- Armazón de madera

Seleccione la clase, mas sepa que la superficie debe estar nivelada y plana antes de comenzar el armado. Si la superficie no está nivelada y plana de manera adecuada, el cobertizo no podrá armarse correctamente. La nivelación de la superficie le ahorrará tiempo de trabajo, por lo tanto, le pedimos que no ignore este paso. **Recomendamos una plataforma hecho de concreto. Será la elección más perdurable. La plataforma debe ser construida arriba del suelo para evitar el aflujo de agua dentro del cobertizo. ¡Toda la madera debe estar clasificada para el uso externo!**



• Il faut construire une plate-forme sur laquelle vous devez assembler votre abri. Il est possible que votre quartier exige une documentation visant les permis de construire. Consultez tous les codes du bâtiment locaux, ainsi que les décrets des villes et comtés, pour vérifier que la construction de l'abri extérieur n'exige pas un permis de construire. Avant de commencer l'assemblage, il faut couler ou construire une plate-forme. Il y a deux styles :

- Béton
- Cadre à bois

Sélectionnez le style, mais sachez que la surface d'installation doit être de niveau et plate. Si la surface n'est pas correctement de niveau et plate, l'assemblage de l'abri ne se fera pas correctement. Vous gagnerez du temps sur le long terme grâce à une surface bien de niveau, ne négligez donc pas cette étape. **Nous recommandons une plate-forme en Béton. Ce choix sera le plus durable. La plate-forme que vous choisissez doit être construite au-dessus du sol afin d'éviter l'accumulation d'eau à l'intérieur de l'abri. Tous le bois d'oeuvre doit être approuvé pour l'usage à l'extérieur !**

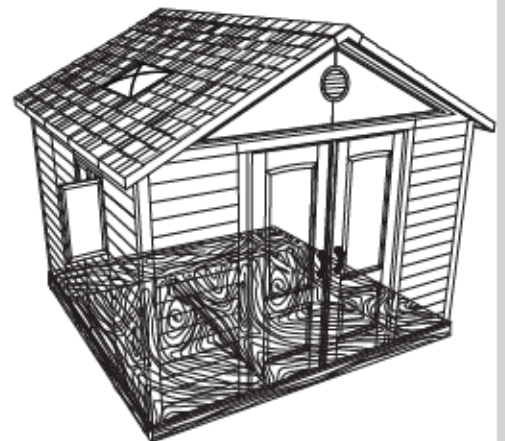
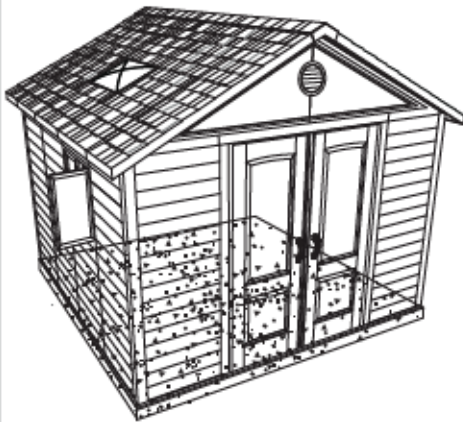

## ► SECTION 1 (CONTINUED) / SECCIÓN 1 (SIGUE) / SECTION 1 (SUITE)

CONCRETE REQUIRED / CONCRETO REQUERIDO / BÉTON REQUIS



1.3 yd<sup>3</sup> (0,99 m<sup>3</sup>)

# 1.1

### CONCRETE PLATFORM / PLATAFORMA DE CONCRETO / PLATE-FORME EN BÉTON

- The concrete should be approximately 4" (10,2 cm) thick. The actual dimensions of the shed, at its widest and longest points, are 132" x 132" (3,35 m x 3,35 m). Ensure you select a site that will accommodate these measurements. **The floor dimensions are a bit smaller than those of the roof; therefore, you will need to build a level surface of 123 1/2" x 123 1/2" (3,14 m x 3,14 m).**
- El concreto debe tener, por lo menos, 10,2 cm (4") de espesor. Las dimensiones reales del cobertizo, a sus puntos más ancho y largo, son 3,35 m x 3,35 m (132" x 132"). Asegúrese de seleccionar un sitio que acomodará estas medidas. **Las dimensiones del piso del cobertizo son más pequeñas que el tejado; entonces, necesitará crear una superficie nivel de 3,14 m x 3,14 m (123 1/2" x 123 1/2").**
- Le béton doit être un épaisseur de 10,2 cm (4"). Les dimensions réelles de votre abri, aux points les plus large et long, sont 3,35 m x 3,35 m (132" x 132"). Assurez-vous de sélectionner un site qui accommodera ces dimensions. **Les dimensions du plancher de votre abri sont plus petites que le toit; ensuite, il faut créer une surface horizontale de 3,14 m x 3,14 m (123 1/2" x 123 1/2").**

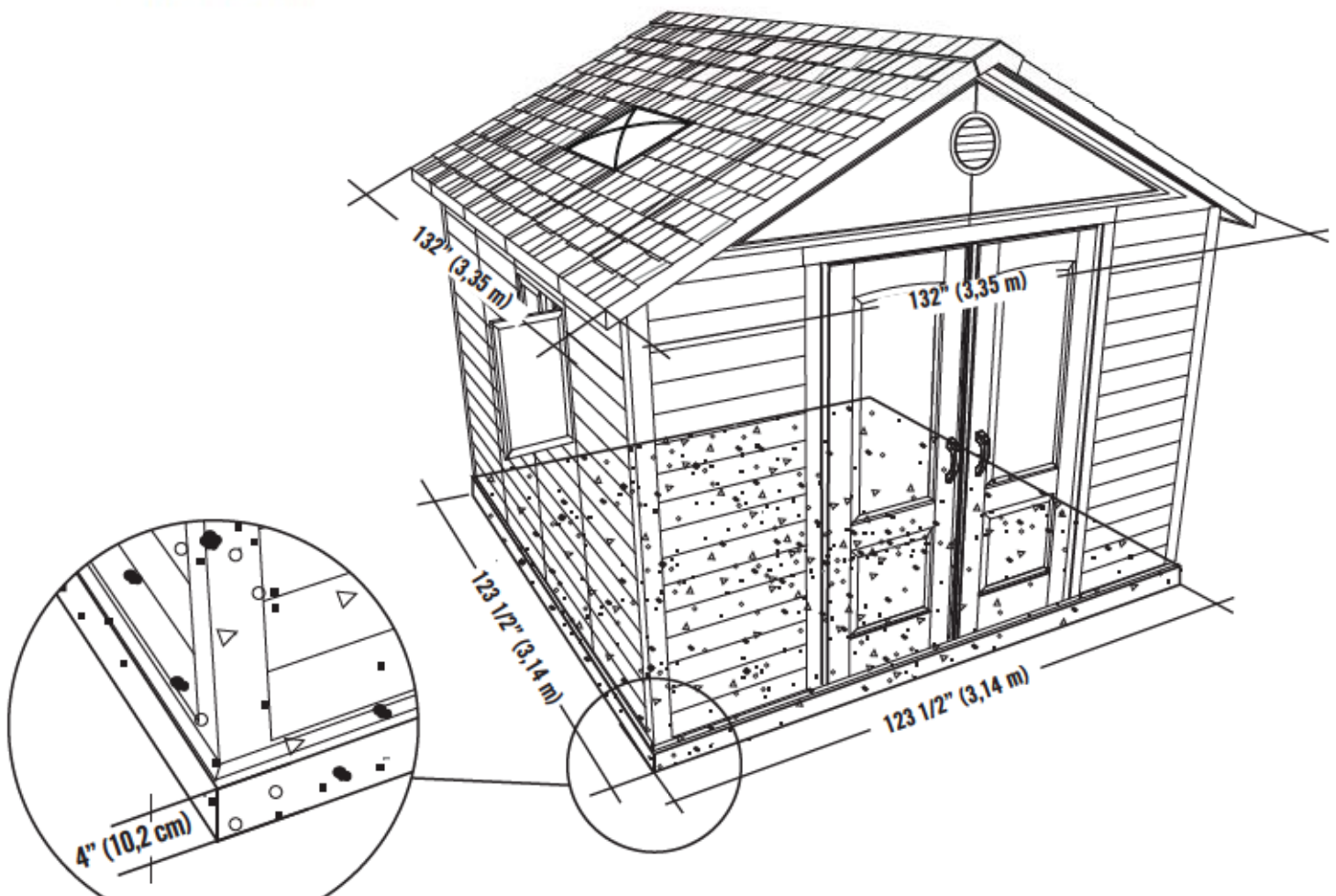

## ► SECTION 1 (CONTINUED) / SECCIÓN 1 (SIGUE) / SECTION 1 (SUITE)

WOOD REQUIRED / MADERA REQUERIDA / BOIS REQUIS



### 1.2

#### WOOD PLATFORM / PLATAFORMA DE MADERA / PLATE-FORME EN BOIS

- The actual dimensions of the shed, at its widest and longest points, are 132" x 132" (3,35 m x 3,35 m). Ensure you select a site that will accommodate these measurements. **The floor dimensions are a bit smaller than those of the roof; therefore, you will need to build a level surface of 123 1/2" x 123 1/2" (3,14 m x 3,14 m).**
- Las dimensiones reales del cobertizo, a sus puntos más ancho y largo, son 3,35 m x 3,35 m (132" x 132"). Asegúrese de seleccionar un sitio que acomodará estas medidas. **Las dimensiones del piso del cobertizo son más pequeñas que el tejado; entonces, necesitará crear una superficie nivel de 3,14 m x 3,14 m (123 1/2" x 123 1/2").**
- Les dimensions réelles de votre abri, aux points les plus large et long, sont 3,35 m x 3,35 m (132" x 132"). Assurez-vous de sélectionner un site qui accommodera ces dimensions. **Les dimensions du plancher de votre abri sont plus petites que le toit; ensuite, il faut créer une surface horizontale de 3,14 m x 3,14 m (123 1/2" x 123 1/2").**

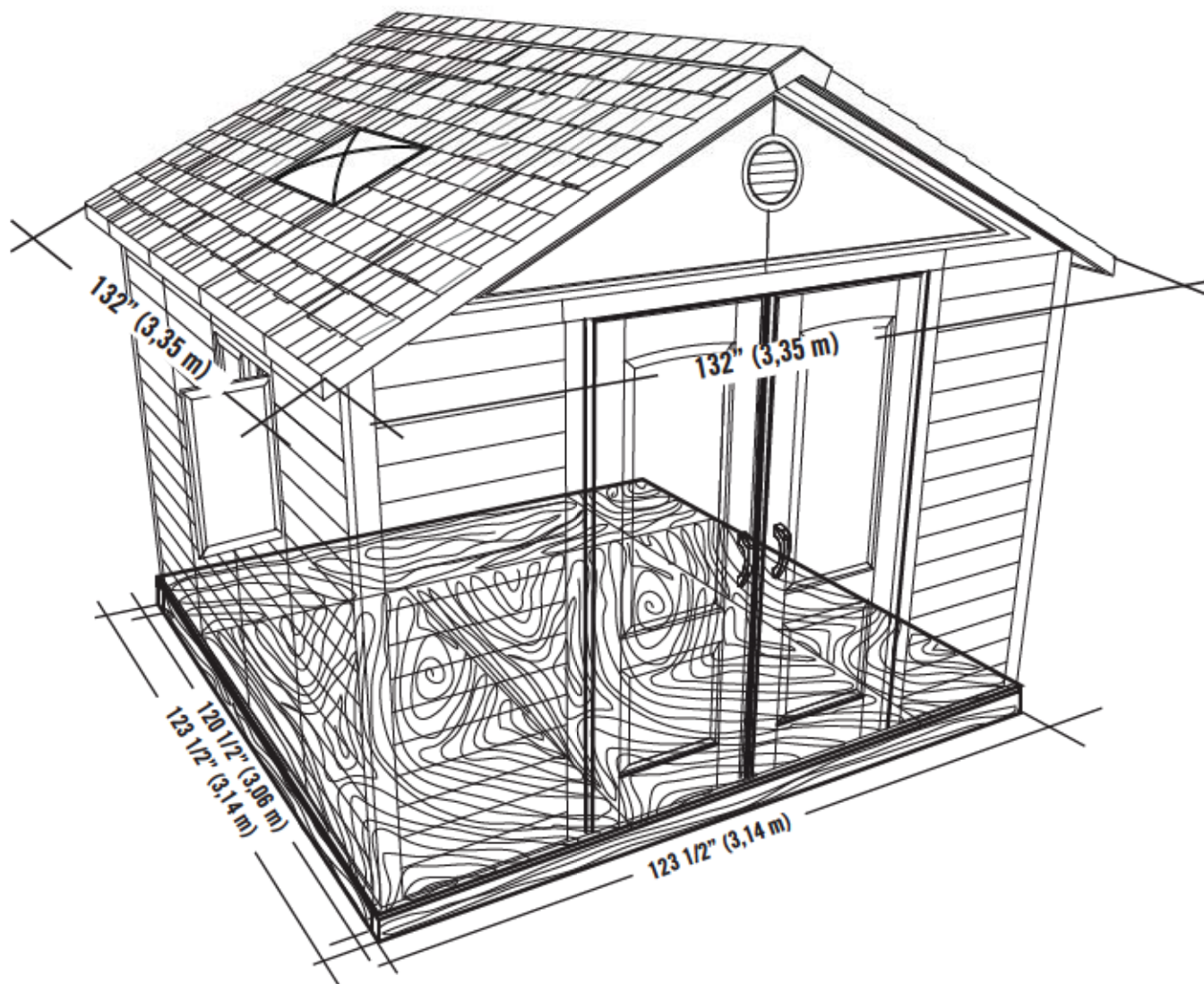

## ► SECTION 1 (CONTINUED) / SECCIÓN 1 (SIGUE) / SECTION 1 (SUITE)

TOOLS, PARTS, AND HARDWARE REQUIRED / HERRAMIENTAS, PIEZAS, Y ACCESORIOS REQUERIDOS / OUTILS, PIÈCES, ET ACCESSOIRES REQUIS

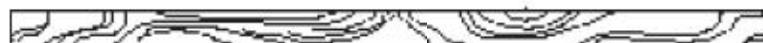

2" x 4" x 120 1/2" (5,1 cm x 10,2 cm x 3,06 m) (x9)



2" x 4" x 123 1/2" (5,1 cm x 10,2 cm x 3,14 m) (x2)

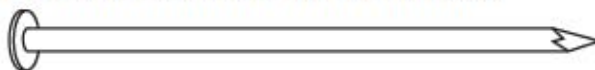

16d 3" (16d x 7,62 cm) (x36)

### 1.2.1

#### WOOD PLATFORM / PLATAFORMA DE MADERA / PLATE-FORME EN BOIS

- Ensure all lumber is treated and approved for outdoor use. Build frame to 123 1/2" x 123 1/2" (3,14 m x 3,14 m) (outside dimensions). You can also use the plywood as a flat surface when building this frame.
- Asegure que use madera tratada y aprobada para el uso externo. Construye el armazón a 3,14 m x 3,14 m (123 1/2" x 123 1/2") (dimensiones exteriores). Se puede también usar el contrachapado como una superficie plana al ensamblar este armazón.
- Vérifiez que votre bois d'œuvre a été traité et approuvé pour l'utilisation à l'extérieur. Construisez un cadre de 3,14 m x 3,14 m (123 1/2" x 123 1/2") (dimensions extérieures). Vous pouvez aussi utiliser le contreplaqué comme une surface plate pendant l'assemblage de ce cadre.

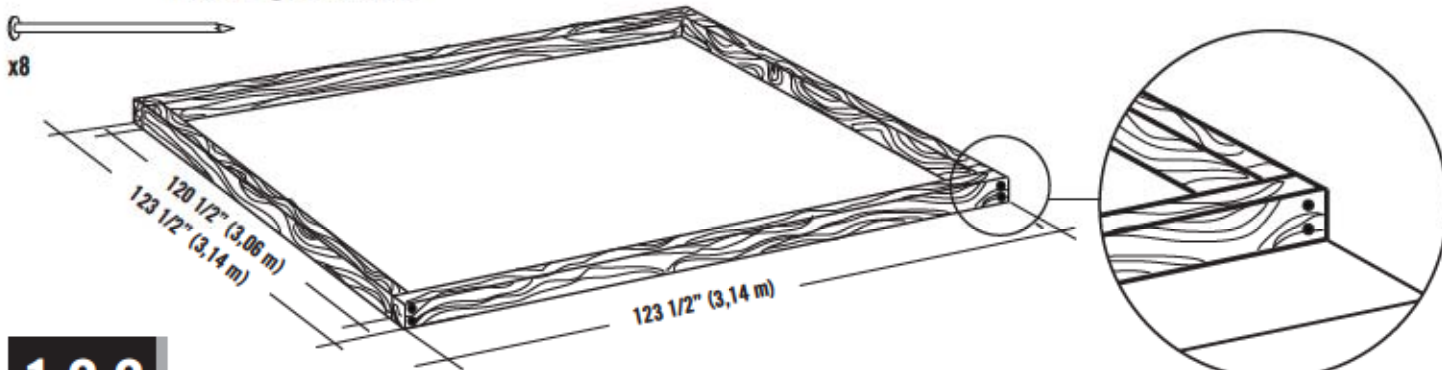

### 1.2.2

- To ensure studs are in the correct location for nailing plywood in the next step, start measuring from the corner 16" (40,1 cm), and then measure from center to center.
- Para asegurarse que los montantes están en las ubicaciones correctas para el contrachapado en el paso siguiente, comience a medir desde el borde del montante hasta el centro del próximo montante 40,1 cm (16"). Luego, tome la medida de centro a centro en los montantes restantes.
- Pour être sûr d'avoir assez de montant pour clouer le contreplaqué dans le prochaine étape, commencez à mesurer à partir de cette montant 40,1 cm (16") vers le centre du deuxième montant. Ensuite, mesurez de centre à centre pour les montants restants.

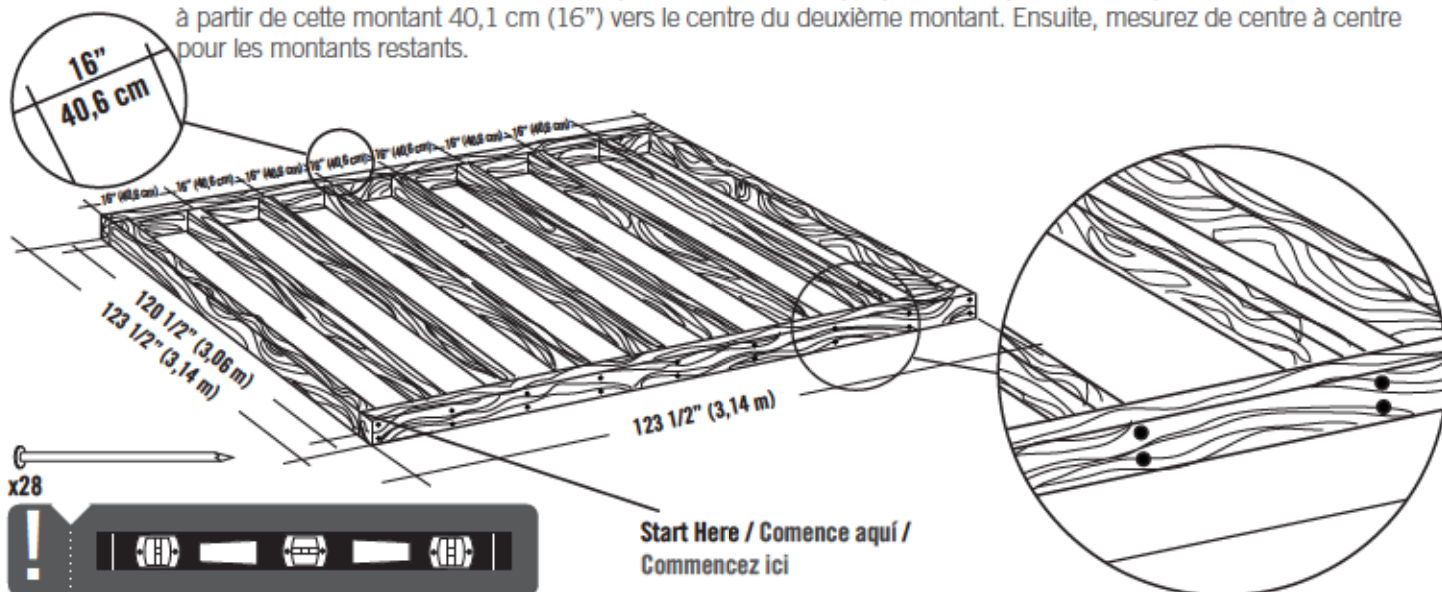

## ► SECTION 1 (CONTINUED) / SECCIÓN 1 (SIGUE) / SECTION 1 (SUITE)

TOOLS, PARTS, AND HARDWARE REQUIRED / HERRAMIENTAS, PIEZAS, Y ACCESORIOS REQUERIDOS / OUTILS, PIÈCES, ET ACCESSOIRES REQUIS



48" x 96" x 3/4" (1,22 m x 2,44 m x 19,1 cm) (x2)



27 1/2" x 96" x 3/4" (70 cm x 2,44 m x 19,1 cm) (x2)



27 1/2" x 27 1/2" x 3/4" (70 cm x 70 cm x 19,1 cm) (x1)



8d 1 1/2" Common Nail (8d x 12,7 mm) (x76)

### 1.2.3

- Square the frame, measuring from corner to corner. **Measurement A & B should be about the same length.**
- Cuadre el armazón midiendo de esquina a esquina. **La medida «A» y «B» deben ser aproximadamente el mismo largo.**
- Carrez le cadre en mesurant d'angle à angle. **La mesure «A» et «B» doivent être à peu près la même longueur.**

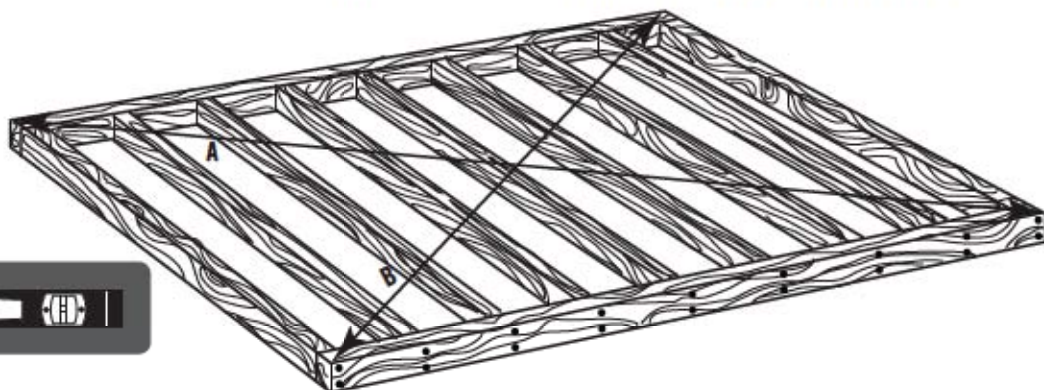

! A = B



### 1.2.4

- Using nails, fasten the plywood to the frame. Then, drill 5/16" holes for drainage.
- Usando unos clavos, sujete el contrachapado al armazón. Entonces, taladre agujeros de 7,9 mm para el drenaje.
- En utilisant des clous, attachez bien le contreplaqué au cadre. Ensuite, percez des trous de 7,9 mm pour le drainage.

x76

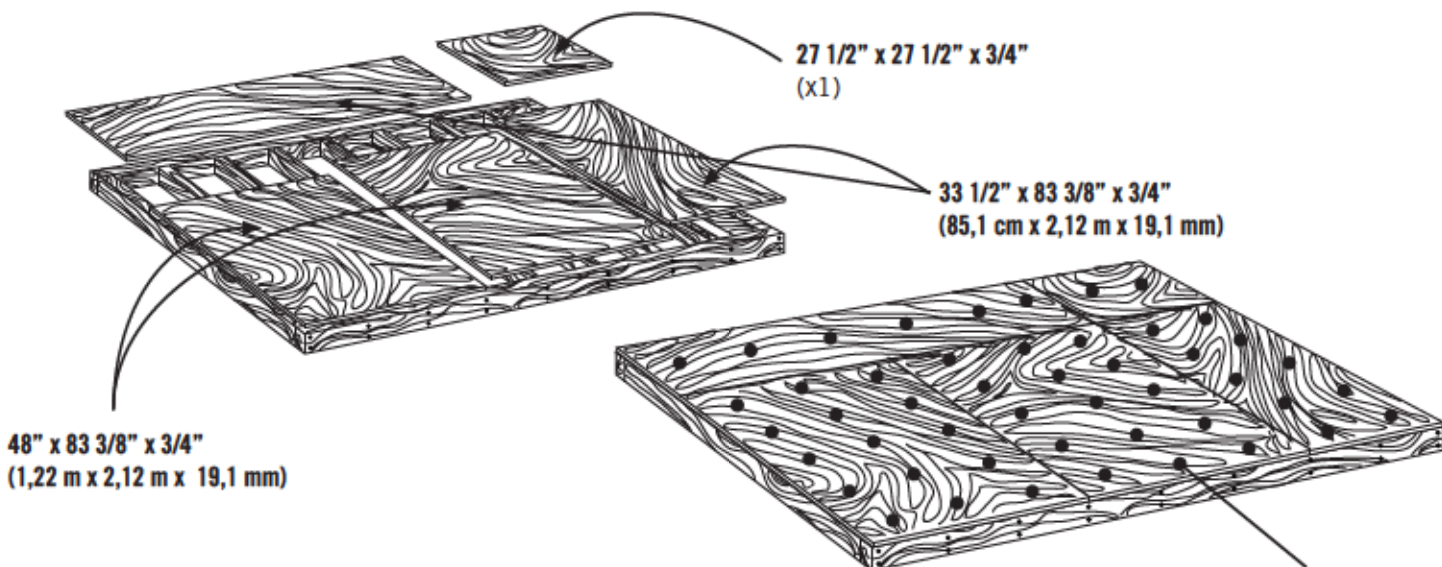

Drainage Holes  
Agujeros para canalización  
Trous de drainage

x48!



# 2

## TRUSS ASSEMBLY / ENSAMBLAJE DE LOS ARMAZONES / ASSEMBLAGE DES FERMES



### HARDWARE REQUIRED / ACCESORIOS REQUERIDOS / ACCESSOIRES REQUIS

Hardware Bag / Bolsa de accesorios / Sac d'accessoires

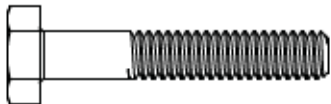

AAK (x40)



ADJ (x40)



AIP (x4)



AHT (x8)



### PARTS REQUIRED / PIEZAS REQUERIDAS / PIÈCES REQUISES

Metal Parts / Piezas de metal / Pièces en métal



71 11/16" (1,82 m)

AFH (x8)



79 1/2" (2,02 m)

AFG (x4)



79 1/2" (2,02 m)

AFQ (x8)



20 1/8" (51 cm)

AFP (x8)



### TOOLS REQUIRED / HERRAMIENTAS REQUERIDAS / OUTILS REQUIS



7/16" (11,1 mm) (x2)

## ► SECTION 2 (CONTINUED) / SECCIÓN 2 (SIGUE) / SECTION 2 (SUITE)

TOOLS AND HARDWARE REQUIRED / HERRAMIENTAS Y ACCESORIOS REQUERIDOS / OUTILS ET ACCESSOIRES REQUIS

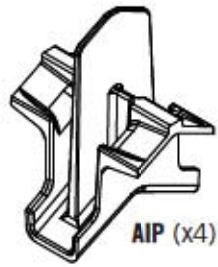

### 2.1

- Place a **Truss Connector (AIP)** down inside the ends of two **Truss Gutter Channels (AFH)** as shown.
- Coloque un **Connector de canales (AIP)** en los extremos de dos **Canalones del armazón (AFH)** como se muestra.
- Insérez un **Raccord à fermes (AIP)** dans les extrémités de deux **Canaux de gouttière (AFH)** comme illustré.

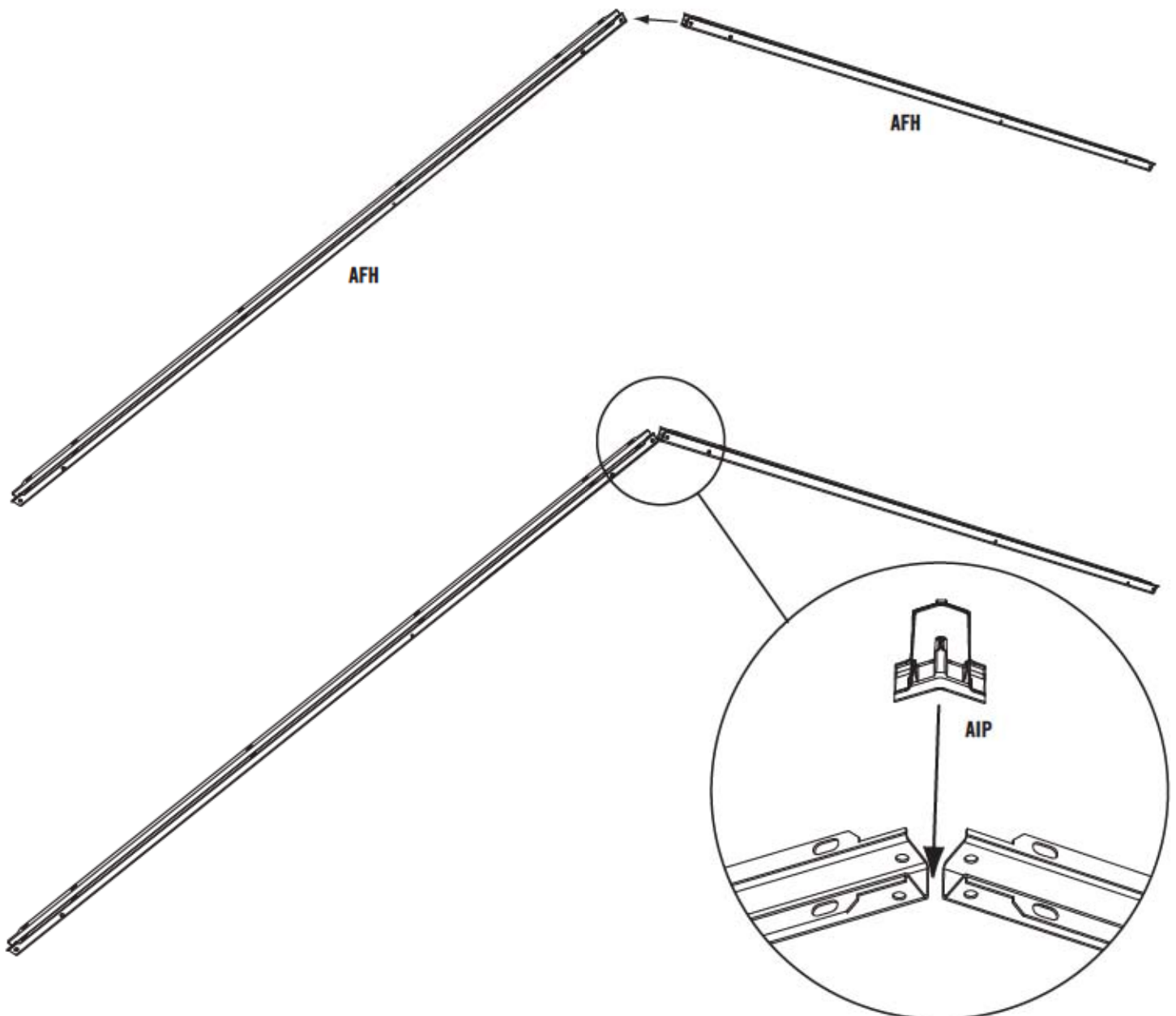

## ► SECTION 2 (CONTINUED) / SECCIÓN 2 (SIGUE) / SECTION 2 (SUITE)

TOOLS AND HARDWARE REQUIRED / HERRAMIENTAS Y ACCESORIOS REQUERIDOS / OUTILS ET ACCESSOIRES REQUIS



7/16" (x2)  
11,1 mm (x2)

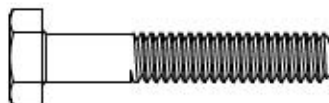

AAK (x8)



ADJ (x8)

### 2.2

• Insert two (2) **Bolts (AAK)** through the first **Vertical Truss Brace (AFP)**, the holes in the Truss Gutter Channels, over the Truss Connector, and out through the Truss Gutter Channels and second **Vertical Truss Support (AFP)**. Secure with two **Cap Nuts (ADJ)**. **Do not overtighten the Nuts.**

• Inserte dos (2) **Pernos (AAK)** a través del primer **Soporte vertical (AFP)**, los agujeros en los Canales del armazón, encima del Conector de canales, y a través de los Canales del armazón y el segundo **Soporte vertical (AFP)**. Sujételos con dos **Tuercas ciegas (ADJ)**. **No apriete demasiado las Tuercas.**

• Insérez deux (2) **Boulons (AAK)** à travers le premier **Support vertical (AFP)**, les trous dans les Canaux de gouttière, over le Raccord à fermes, et à travers les Canaux et le deuxième **Support vertical (AFP)**. Attachez-les bien à l'aide de deux **Écrous à chape (ADJ)**. **Ne pas trop serrer.**

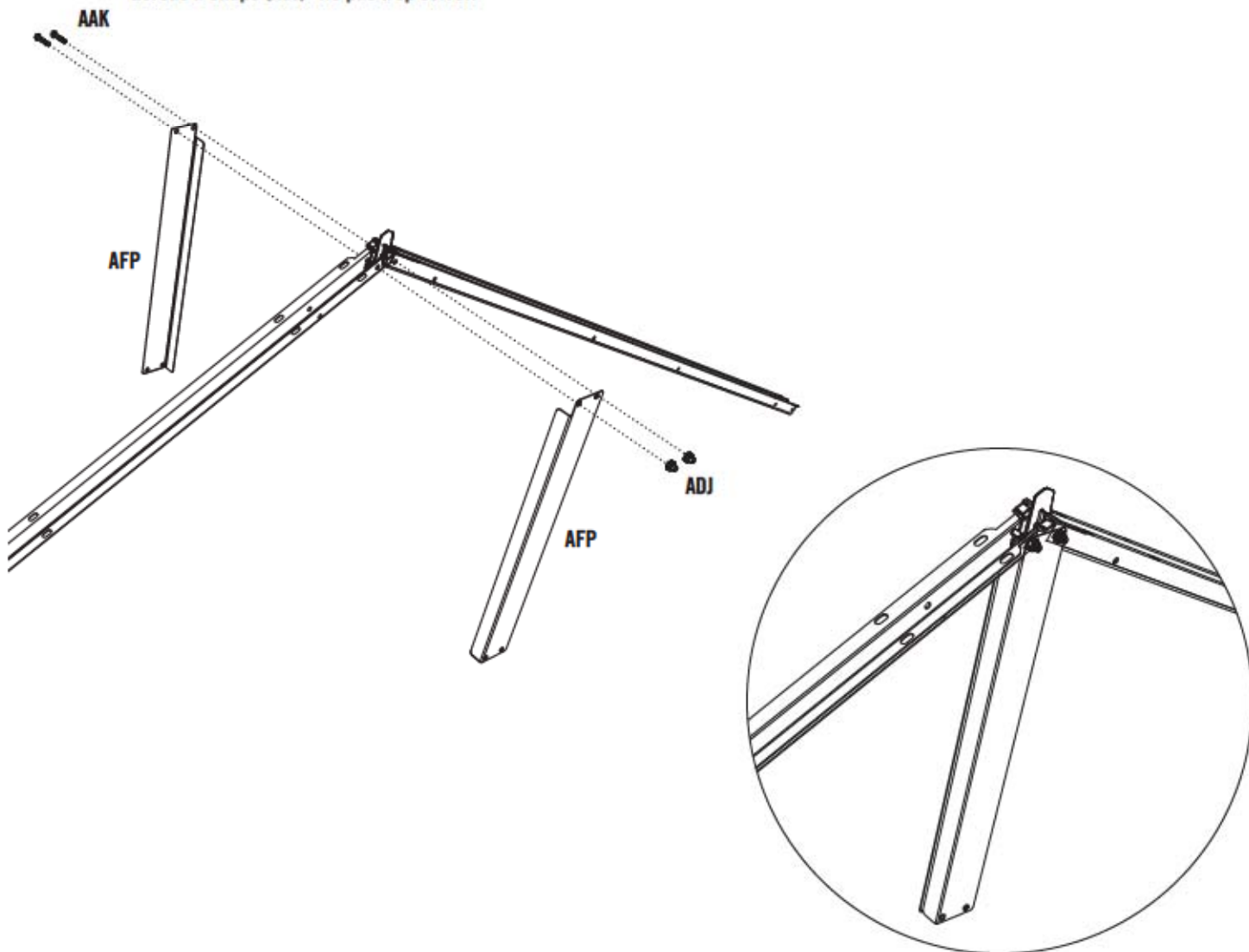

## ► SECTION 2 (CONTINUED) / SECCIÓN 2 (SIGUE) / SECTION 2 (SUITE)

TOOLS AND HARDWARE REQUIRED / HERRAMIENTAS Y ACCESORIOS REQUERIDOS / OUTILS ET ACCESSOIRES REQUIS



7/16" (x2)  
11,1 mm (x2)

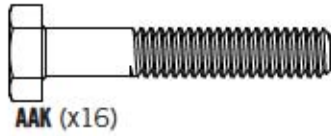

AAK (x16)



ADJ (x16)

### 2.3

- Secure a **Horizontal Truss Brace (AFG)** to the Channels and the Vertical Truss Braces using four (4) **Bolts (AAK)** and **Cap Nuts (ADJ)**. **Do not overtighten the Nuts.**
- Sujete un **Soporte horizontal (AFG)** a los Canalones y los Soportes verticales usando cuatro (4) **Pernos (AAK)** y **Tuercas ciegas (ADJ)**. **No apriete demasiado las Tuercas.**
- Attachez bien un **Support horizontal (AFG)** aux Canaux et aux Supports verticaux à l'aide de quatre (4) **Boulons (AAK)** et **Écrous à chape (ADJ)**. **Ne pas trop serrer.**

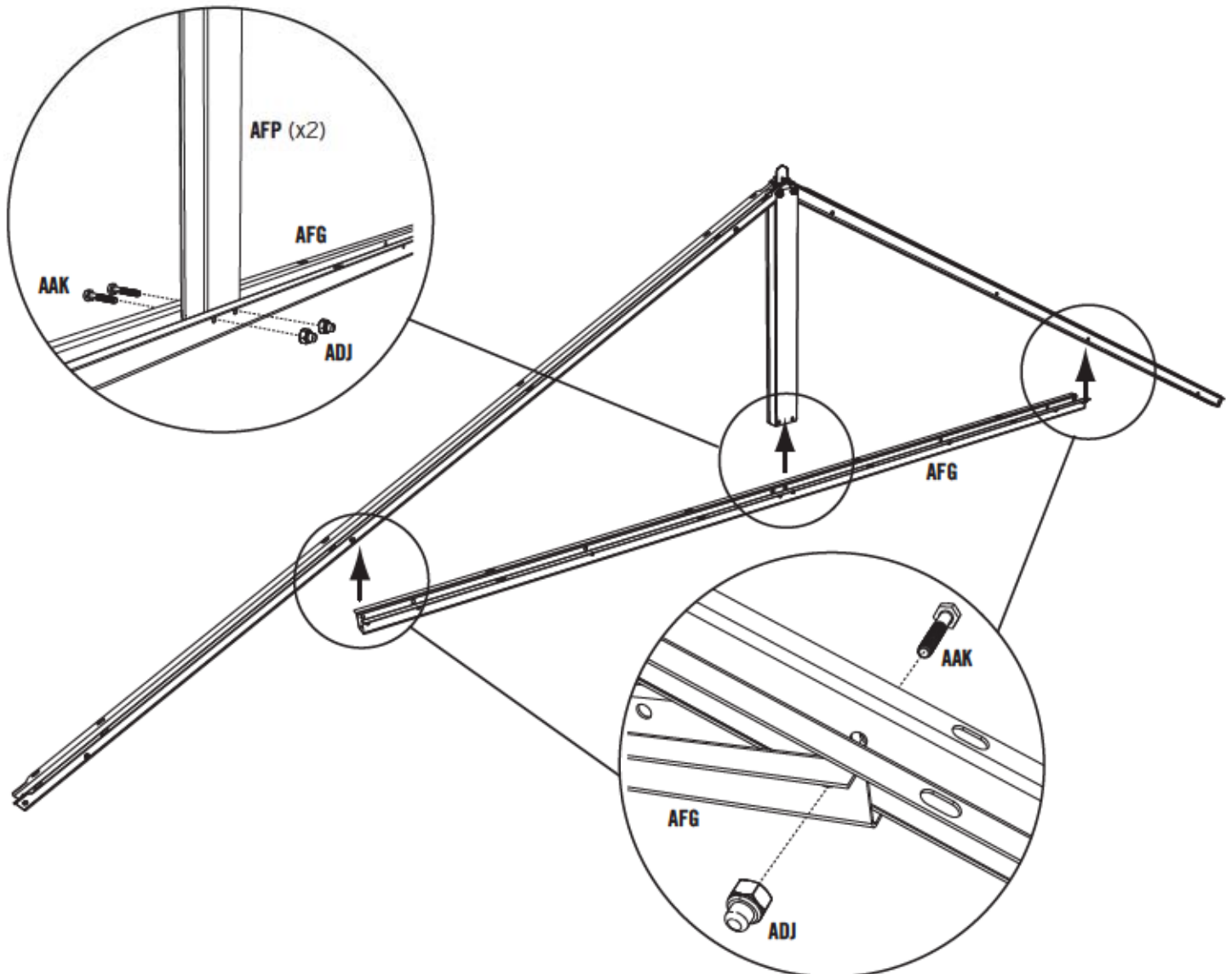

## ► SECTION 2 (CONTINUED) / SECCIÓN 2 (SIGUE) / SECTION 2 (SUITE)

TOOLS AND HARDWARE REQUIRED / HERRAMIENTAS Y ACCESORIOS REQUERIDOS / OUTILS ET ACCESSOIRES REQUIS



7/16" (x2)  
11,1 mm (x2)

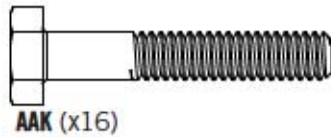

AAK (x16)



ADJ (x16)



AHT (x8)

### 2.4

- Attach a **Wall Support Channel (AFQ)** to each end of the Truss Assembly using the hardware provided. **Do not overtighten.**
- Sujete un **Canal de soporte para el muro (AFQ)** a cada extremo del Conjunto del armazón usando los accesorios provistos. **No apriete demasiado.**
- Attachez un **Canal de support à mur (AFQ)** à chaque extrémité de l'Ensemble de la ferme à l'aide des accessoires fournis. **Ne pas trop serrer.**

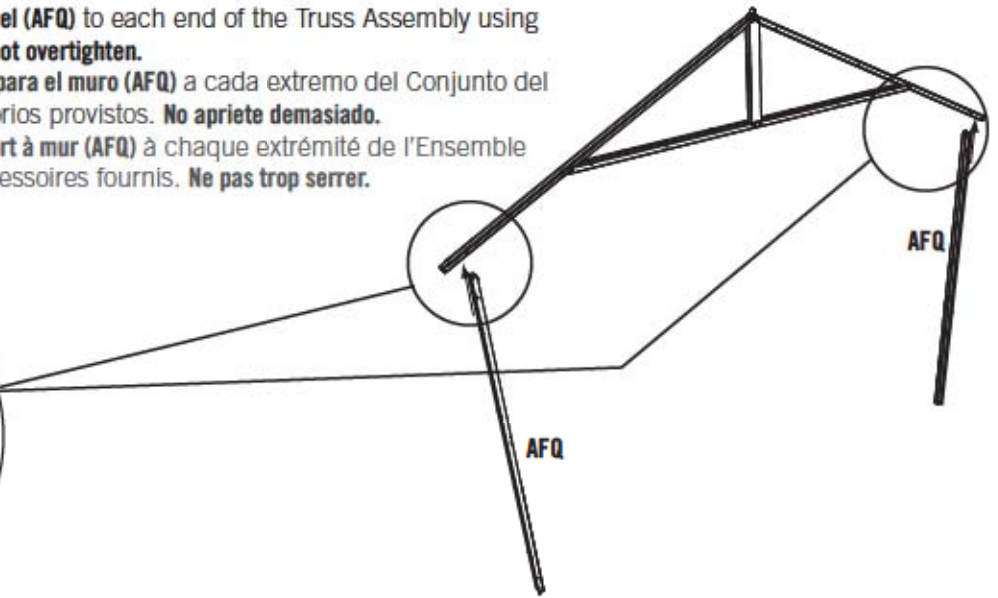
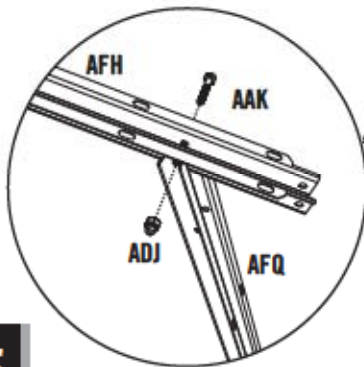

### 2.5

- Attach a **Floor Bracket (AHT)** to the bottom of each Wall Support Channel. **Do not overtighten. Repeat this section three times.**
- Sujete un **Soporte para el piso (AHT)** al extremo inferior de cada Canal de soporte para el muro. **No apriete demasiado. Repita esta sección tres veces.**
- Attachez un **Support à plancher (AHT)** à l'extrémité inférieure de chaque Canal de support à mur. **Ne pas trop serrer. Répétez cette section trois fois.**

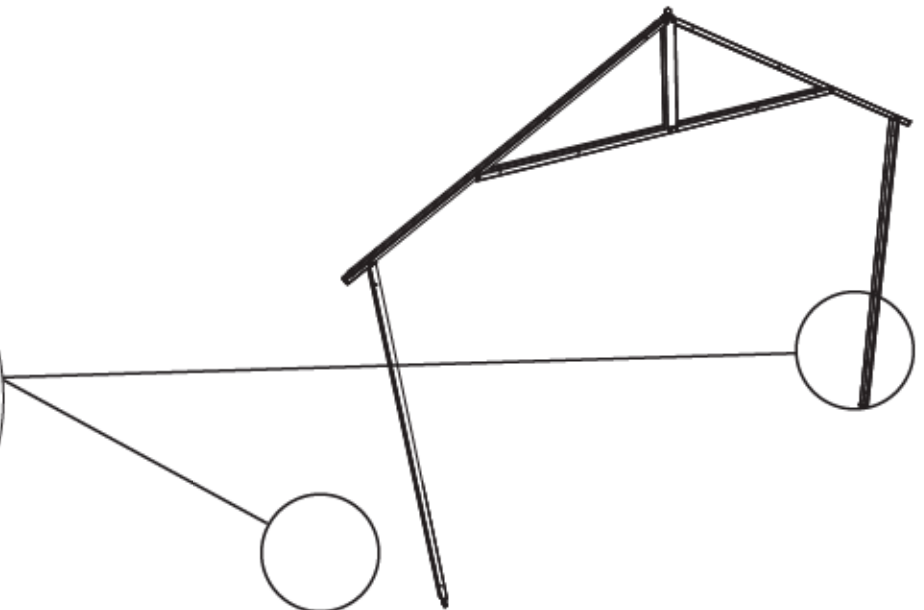
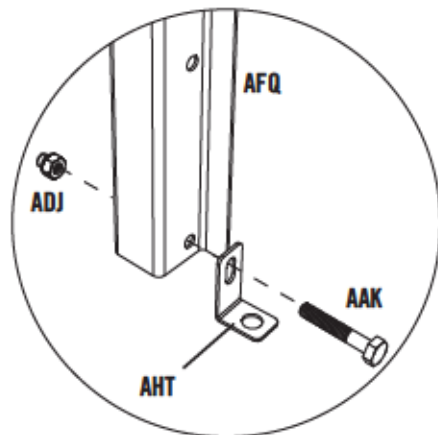

# 3

## GABLE ASSEMBLY / ENSAMBLAJE DE LAS FACHADAS / ASSEMBLAGE DES TOITS À PIGNON



### HARDWARE REQUIRED / ACCESORIOS REQUERIDOS / ACCESSOIRES REQUIS

Hardware Bag / Bolsa de accesorios / Sac d'accessoires



AEE (x10)

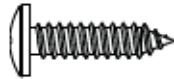

ADW (x10)

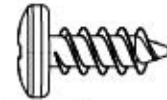

ADZ (x8)

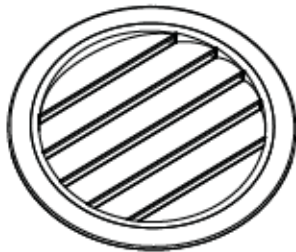

AGP (x2)

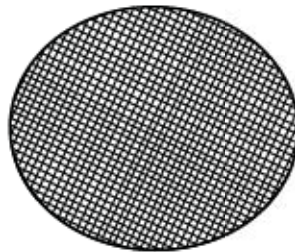

AIQ (x2)



### PARTS REQUIRED / PIEZAS REQUERIDAS / PIÈCES REQUISES

Plastic Parts / Piezas de plástico / Pièces en plastique

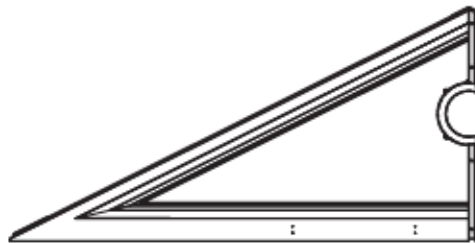

AGH (x2)

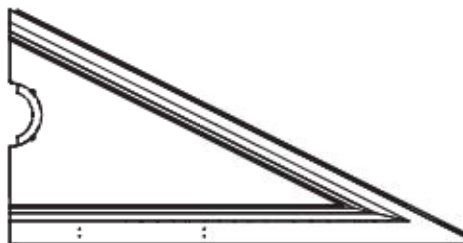

AGI (x2)



### TOOLS REQUIRED / HERRAMIENTAS REQUERIDAS / OUTILS REQUIS



## ► SECTION 3 (CONTINUED) / SECCIÓN 3 (SIGUE) / SECTION 3 (SUITE)

TOOLS AND HARDWARE REQUIRED / HERRAMIENTAS Y ACCESORIOS REQUERIDOS / OUTILS ET ACCESSOIRES REQUIS

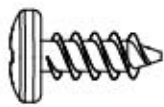

ADZ (x8)



AEE (x10)



ADW (x10)

### 3.1

- Set the edge of **Gable Side A (AGI)** over the edge of **Gable Side B (AGH)**, and align the four holes.
- Coloque el borde de la **Fachada A (AGI)** encima del borde de la **Fachada B (AGH)**, y alinee los cuatro agujeros.
- Mettez le bord du **Toit à pignon A (AGI)** sur le bord du **Toit à pignon B (AGH)**, et alignez les quatre trous.

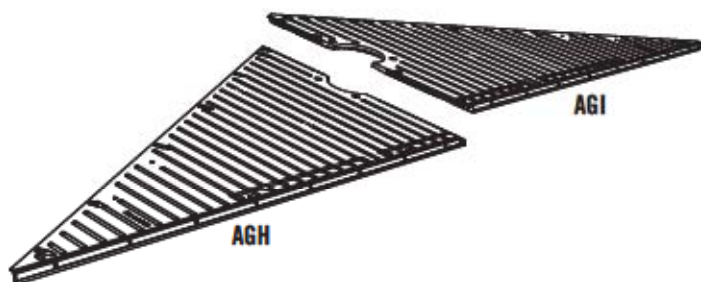

### 3.2

- Secure Gable Side A to Gable Side B using the hardware provided.
- Sujete la Fachada A a la Fachada B usando los accesorios provistos.
- Attachez le Toit à pignon A au Toit à pignon B à l'aide des accessoires fournis.

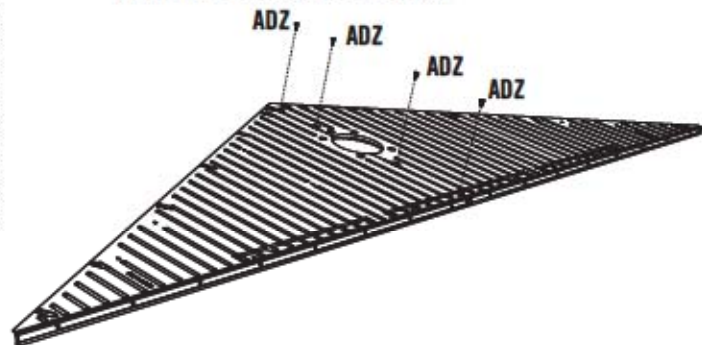

### 3.3

- Place a **Screen (AIQ)** over a **Vent (AGP)**. Set the Gable Assembly over the Screen and Vent so the holes in the Gable align with those in the Vent. Secure with the hardware provided.
- Coloque un **Mosquitero (AIQ)** encima de una **Ventila (AGP)**. Coloque la Fachada encima del Mosquitero y la Ventila para que los agujeros en la Fachada se alineen con ellos en la Ventila. Sujete la la Ventila a la Fachada usando los accesorios provistos.
- Mettez un **Mosquitaire (AIQ)** sur un **Évent (AGP)**. Mettez le Toit à pignon sur le Mosquitaire et l'Évent pour que les trous dans le Toit à pignon s'alignent avec ceux de l'Évent. Attachez l'Évent au Toit à pignon à l'aide des accessoires fournis.

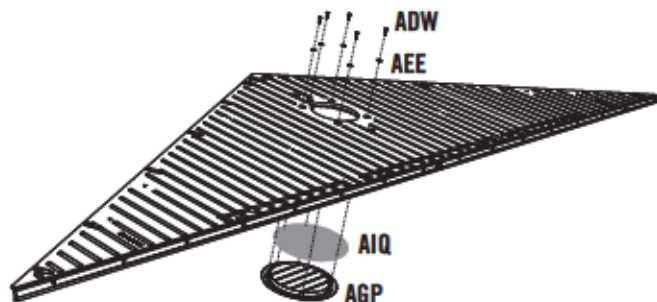

### 3.4

- Repeat these steps for the second Gable.
- Repita estos pasos para la segunda Fachada.
- Répétez ces étapes pour le deuxième Toit à pignon.

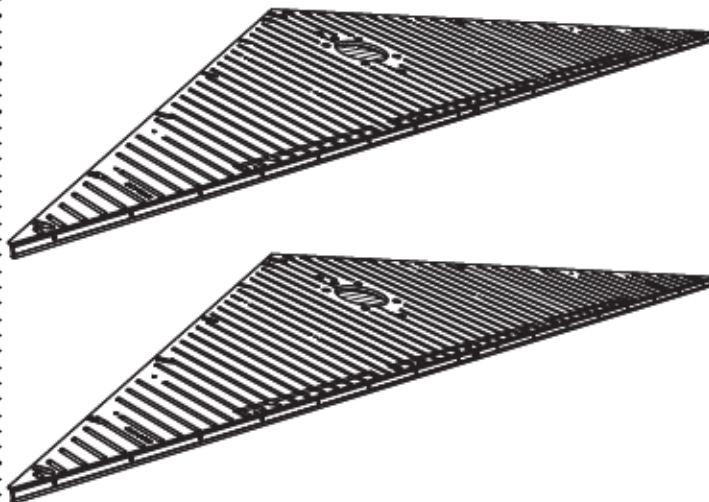

# 4

## LEFT DOOR ASSEMBLY / ENSAMBLAJE DE LA PUERTA IZQUIERDA / ASSEMBLAGE DE LA PORTE GAUCHE



### HARDWARE REQUIRED / ACCESORIOS REQUERIDOS / ACCESSOIRES REQUIS

Hardware Bags / Bolsas de accesorios / Sacs d'accessoires

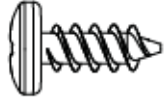

ADZ (x9)



ADW (x3)



ACH (x2)



ADJ (x2)



AEE (x3)



AHZ (x1)



AHM (x2)



AIB (x1)



AIA (x1)



### PARTS REQUIRED / PIEZAS REQUERIDAS / PIÈCES REQUISES

Metal Parts / Piezas de metal / Pièces en métal

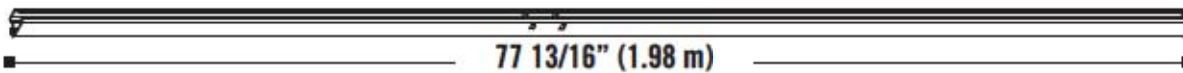

AFC (x1)



18 1/2" (47 cm)  
AFB (x3)

Plastic Parts / Piezas de plástico / Pièces en plastique

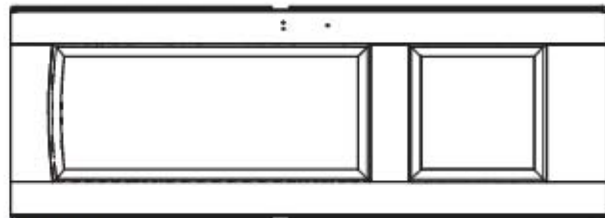

AGO (x1)



### TOOLS REQUIRED / HERRAMIENTAS REQUERIDAS / OUTILS REQUIS



7/16" (11 mm)



## ► SECTION 4 (CONTINUED) / SECCIÓN 4 (SIGUE) / SECTION 4 (SUITE)

TOOLS AND HARDWARE REQUIRED / HERRAMIENTAS Y ACCESORIOS REQUERIDOS / OUTILS ET ACCESSOIRES REQUIS



AHM (x2)

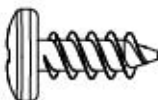

ADZ (x9)

### 4.1

- Set the **Deadbolts (AHM)** down into the recesses at the top and bottom of the Door. Then, slide the **Door End Channel (AFC)** over the edge of the Door and the bottom of the Deadbolts as shown.
- Ponga los **Cerrojos (AHM)** en las muescas a las partes superior et inferior de la Puerta. Entonces, deslice el **Canal para el borde de la puerta (AFC)** sobre el borde de la Puerta y las partes inferiores de los Cerrojos como se muestra.
- Mettez les **Loquets à pêne dormant (AHM)** dans les encoches aux parties supérieure et inférieure de la Porte. Ensuite, faites glisser le **Canal pour l'extrémité de la porte (AFC)** sur le bord de la Porte et les parties inférieures des Loquets à pêne dormant comme illustré.

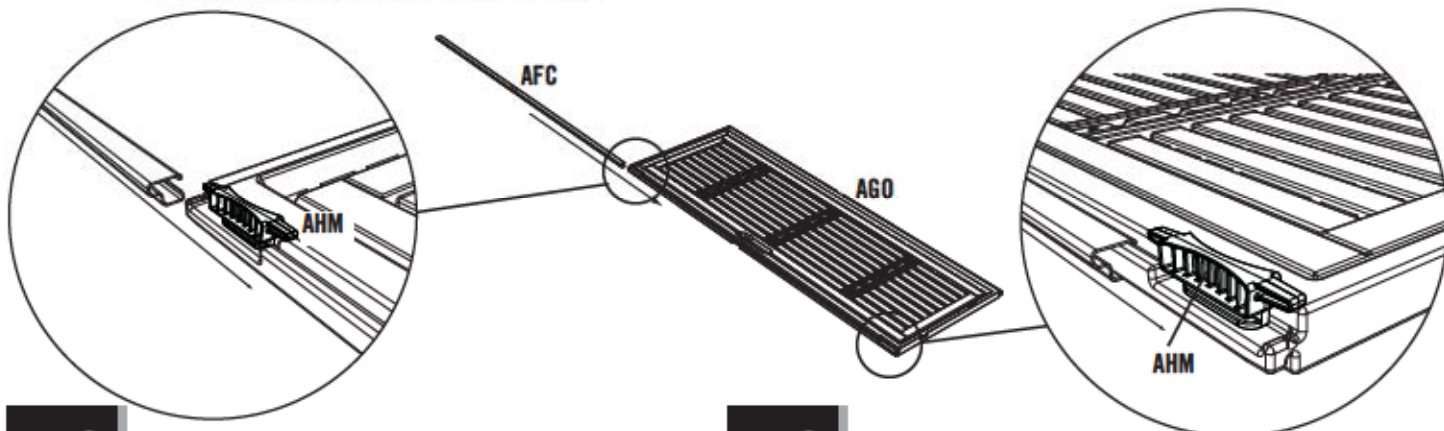

### 4.2

- **Note:** The Deadbolts are used for locking the door. They may not move freely at first. You may need to tap them up and down a few times with a rubber mallet to work them in.
- **Nota:** Se usan los Cerrojos para cerrar la Puerta. Al principio, pueden que no se desplacen libremente. Puede que necesite darlos unos golpecitos con un mazo de goma para aflojarlos.
- **Note :** On utilise les Loquets pour fermer la Porte. Au debut, il se peut que les Loquets ne se déplacent librement. Vous devrez peut-être les taper légèrement à l'aide d'un maillet en caoutchouc pour les desserrer.

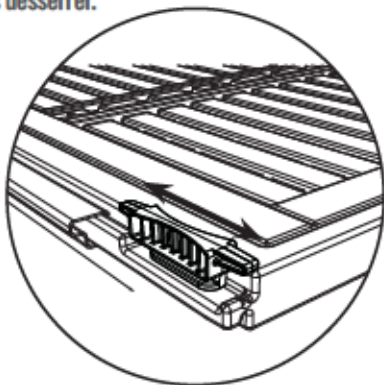

### 4.3

- Attach three (3) **Door Braces (AFB)** to the back of the Left Door.
- Sujete tres (3) **Soportes para la puerta (AFB)** a la cara trasera de la Puerta izquierda.
- Attachez trois (3) **Supports à la porte (AFB)** au côté arrière de la Porte gauche.

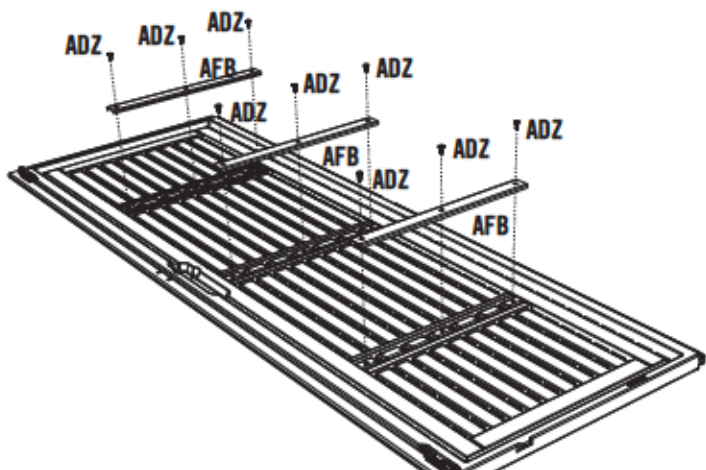

## ► SECTION 4 (CONTINUED) / SECCIÓN 4 (SIGUE) / SECTION 4 (SUITE)

TOOLS AND HARDWARE REQUIRED / HERRAMIENTAS Y ACCESORIOS REQUERIDOS / OUTILS ET ACCESSOIRES REQUIS

  
7/16" (x2)  
11,1 mm (x2)



ACH (x2)



AEE (x3)



ADJ (x2)



AHZ (x1)



AIB (x1)



AIA (x1)



ADW (x3)

### 4.4

- Slide the **Strike Plate (AIB)** over the Door End Channel, and align the holes.
- Deslice la **Placa de refuerzo (AIB)** sobre el Canal para el borde de la puerta, y alinee los agujeros.
- Glissez la **Gâche (AIB)** sur le Canal au bord de la porte, et alignez les trous.

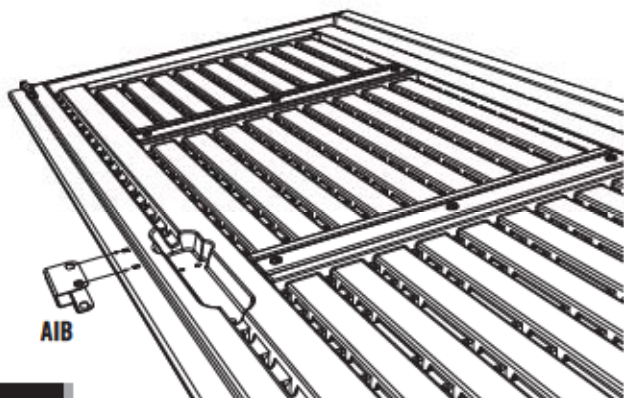

### 4.5

- Secure the **Left Door Latch (AIA)** to the Left Door using the hardware provided. **Do not overtighten.**
- Sujete el **Pestillo de cierre izquierdo (AIA)** a la Puerta izquierda usando los accesorios provistos. **No apriete demasiado.**
- Attachez bien le **Loquet gauche (AIA)** à la Porte gauche à l'aide des accessoires fournis. **Ne pas trop serrer.**

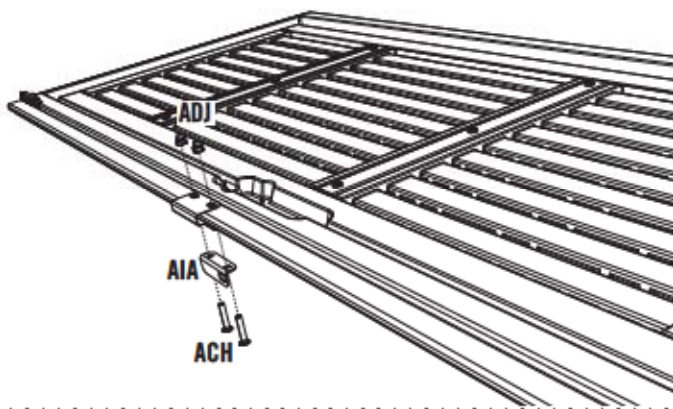

### 4.6

- Secure the **Left Door Handle (AHZ)** to the Left Door using the hardware provided. **Do not overtighten.**
- Sujete el **Picaporte izquierdo (AHZ)** a la Puerta izquierda usando los accesorios provistos. **No apriete demasiado.**
- Attachez bien la **Poignée (AHZ)** à la Porte gauche à l'aide des accessoires fournis. **Ne pas trop serrer.**

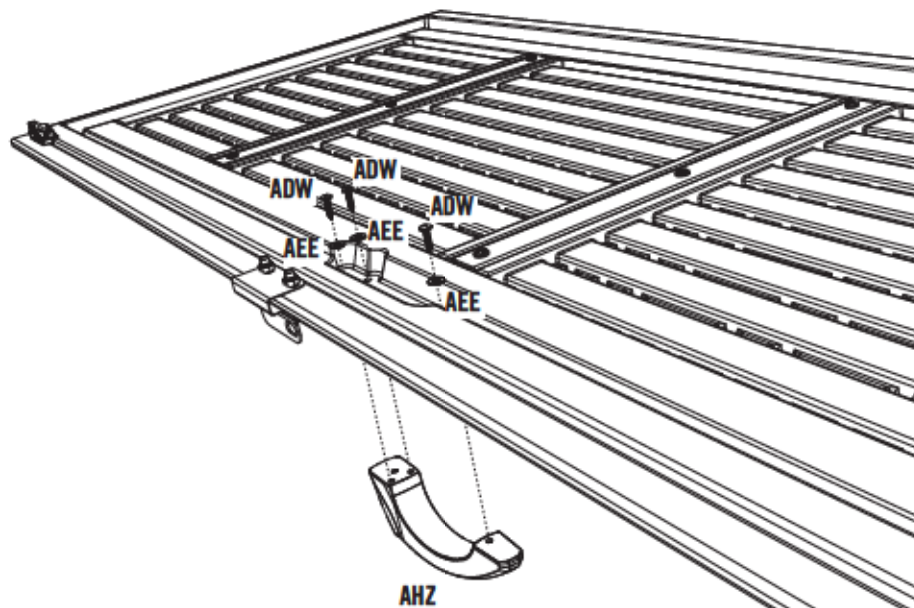

# 5

## RIGHT DOOR ASSEMBLY / ENSAMBLAJE DE LA PUERTA DERECHA / ASSEMBLAGE DE LA PORTE DROITE



### HARDWARE REQUIRED / ACCESORIOS REQUERIDOS / ACCESSOIRES REQUIS

Hardware Bags / Bolsas de accesorios / Sacs d'accessoires



ADZ (x9)



ADW (x4)



AEE (x3)



ADB (x2)



AEB (x2)

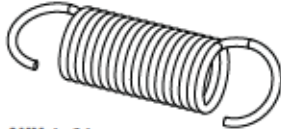

AHY (x1)



ACI (x2)

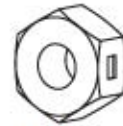

AAB (x2)



AIO (x1)



AHV (x1)



AIK (x1)



AHW (x1)



AIL (x1)



AHX (x1)



### PARTS REQUIRED / PIEZAS REQUERIDAS / PIÈCES REQUISES

Metal Parts / Piezas de metal / Pièces en métal

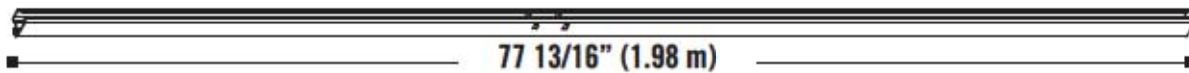

AFC (x1)

77 13/16" (1.98 m)



18 1/2" (47 cm)

AFB (x3)

Plastic Parts / Piezas de plástico / Pièces en plastique

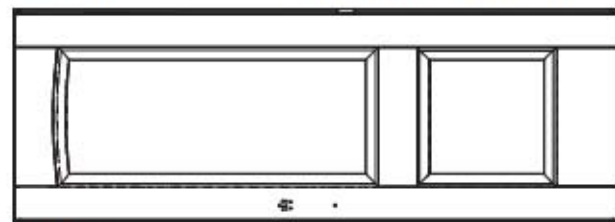

AGZ (x1)



### TOOLS REQUIRED / HERRAMIENTAS REQUERIDAS / OUTILS REQUIS



7/16" (11 mm)



## ► SECTION 5 (CONTINUED) / SECCIÓN 5 (SIGUE) / SECTION 5 (SUITE)

TOOLS AND HARDWARE REQUIRED / HERRAMIENTAS Y ACCESORIOS REQUERIDOS / OUTILS ET ACCESSOIRES REQUIS

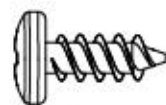

ADZ (9)



AIO (x1)

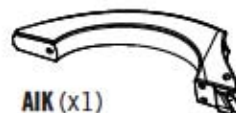

AIK (x1)

### 5.1

- Slide the **Door End Channel (AFC)** over the edge of the Door as shown.
- Deslice el **Canal para el borde de la puerta (AFC)** sobre el borde de la Puerta como se muestra.
- Faites glisser le **Canal pour l'extrémité de la porte (AFC)** sur le bord de la Porte comme illustré.

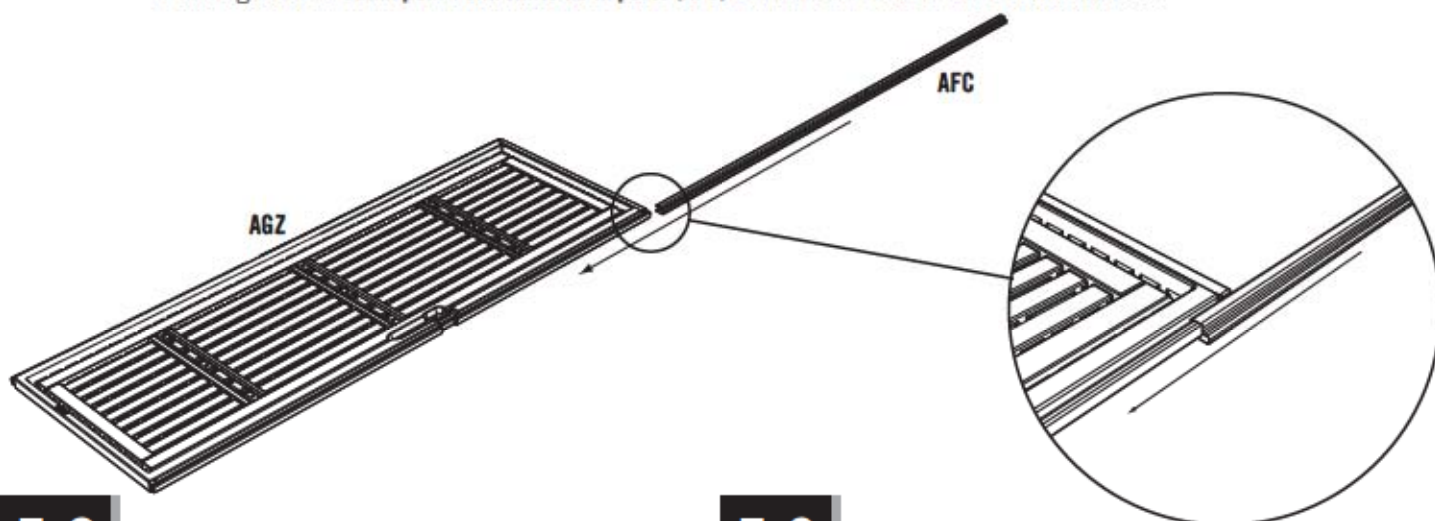

### 5.2

- Attach three (3) **Door Braces (AFB)** to the back of the Right Door.
- Sujete tres (3) **Soportes para la puerta (AFB)** a la cara trasera de la Puerta derecha.
- Attachez trois (3) **Supports à la porte (AFB)** au côté arrière de la Porte droite.

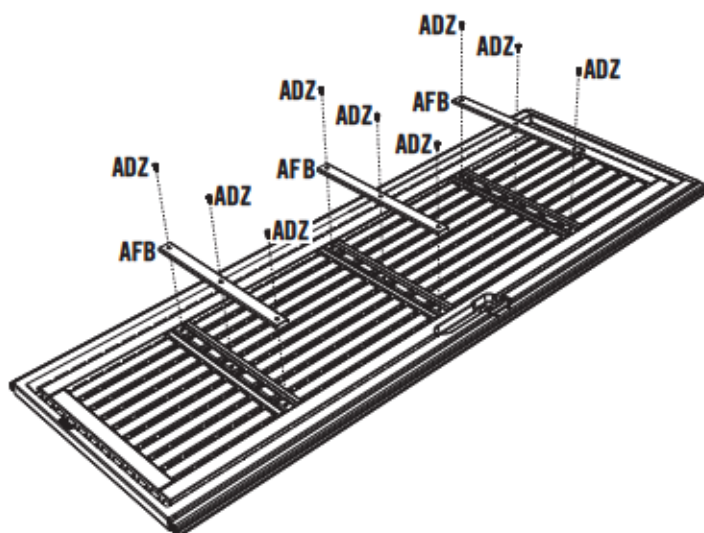

### 5.3

- Slide the **Thumb Lever (AIO)** down into the grooves in the **Door Handle (AIK)** until the nubs fit into the holes.
- Deslice la **Palanca de pulgar (AIO)** en las ranuras del **Picaporte (AIK)** hasta que los nudos se encajen en los agujeros.
- Glissez le **Levier poussoir (AIO)** dans les rainures de la **Poignée (AIK)** jusqu'à ce que les petites bosses se fixent dans les trous.

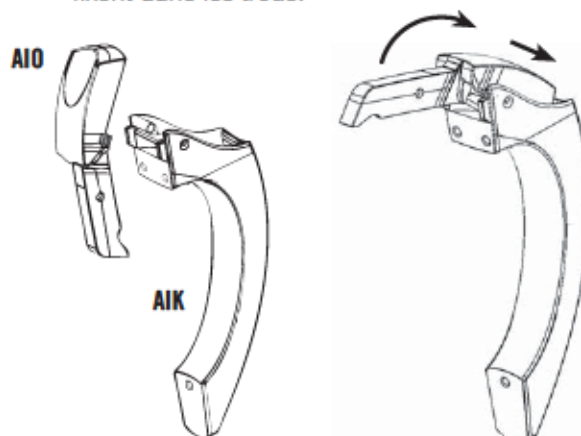

## ► SECTION 5 (CONTINUED) / SECCIÓN 5 (SIGUE) / SECTION 5 (SUITE)

TOOLS AND HARDWARE REQUIRED / HERRAMIENTAS Y ACCESORIOS REQUERIDOS / OUTILS ET ACCESSOIRES REQUIS

  
 7/16" (x2)  
 11,1 mm (x2)

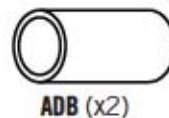
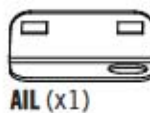
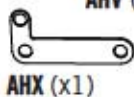
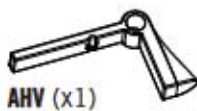
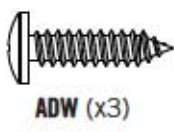

### 5.4

- Insert the Thumb Lever through the slot, and attach the Handle using the hardware provided.
- Inserte la Palanca de pulgar a través de la ranura, y sujete el Picaporte usando los accesorios provistos.
- Insérez le Levier poussoir à travers la fente, et attachez la Poignée à l'aide des accessoires fournis.

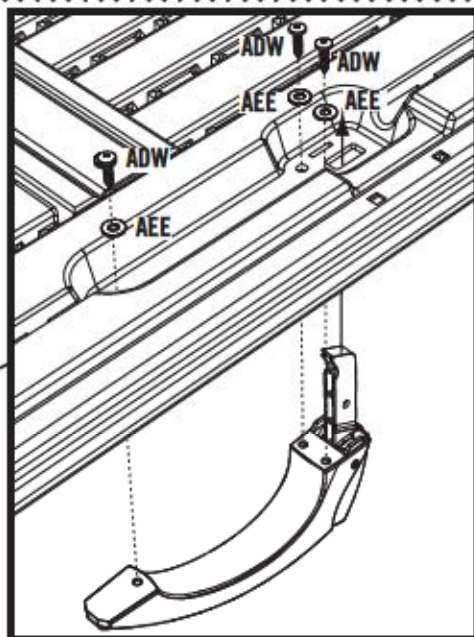
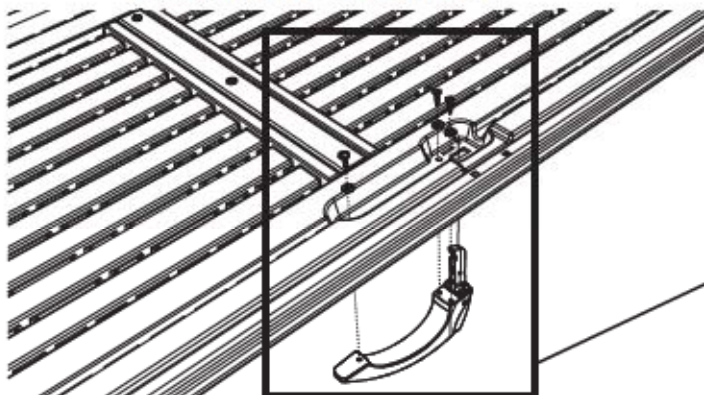

### 5.5

- Attach the Locking Hardware using the hardware provided. **The arm of the Latch rests on top of the Thumb Lever.**
- Sujete los accesorios de cierre usando los accesorios provistos. **El brazo del Pestillo se queda sobre la Palanca de pulgar.**
- Attachez les accessoires de verrouillage à l'aide des accessoires fournis. **Le bras du Loquet doit rester sur le Levier poussoir.**

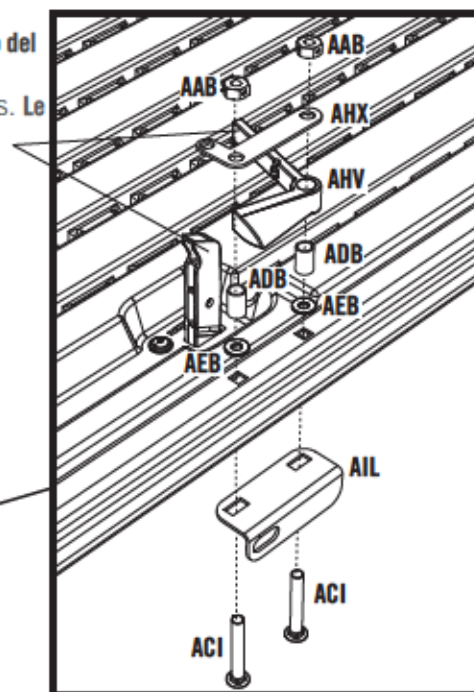
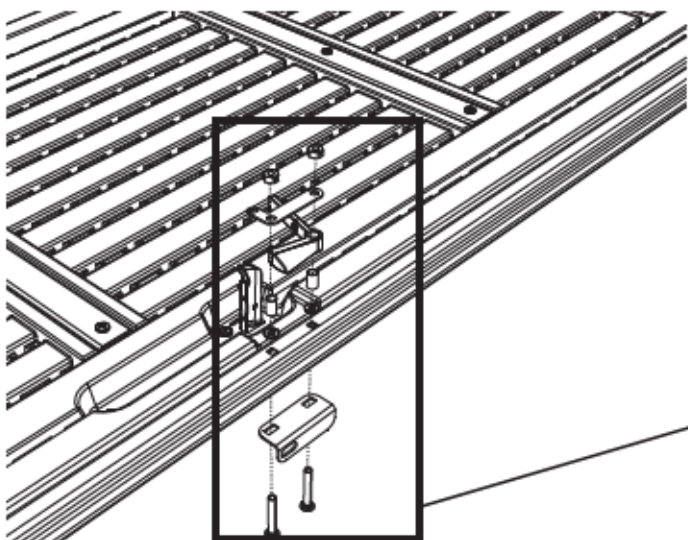

## ► SECTION 5 (CONTINUED) / SECCIÓN 5 (SIGUE) / SECTION 5 (SUITE)

TOOLS AND HARDWARE REQUIRED / HERRAMIENTAS Y ACCESORIOS REQUERIDOS / OUTILS ET ACCESSOIRES REQUIS

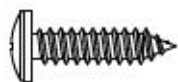

ADW (x1)



AHW (x1)

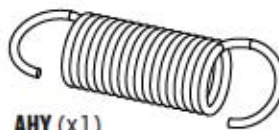

AHY (x1)

### 5.6

- Attach the **Thumb Lever Support (AHW)** to the Thumb Lever (AIO) using a **Screw (ADW)**. The edge of the Support goes underneath the Thumb Lever.
- Sujete el **Soporte de la palanca de pulgar (AHW)** a la Palanca de pulgar (AIO) usando un **Tornillo (ADW)**. El borde del Soporte se fija debajo la Palanca de pulgar.
- Attachez le **Support du levier poussoir (AHW)** au Levier poussoir (AIO) à l'aide d'une **Vis (ADW)**. Le bord du Support se fixe sous le Levier poussoir.

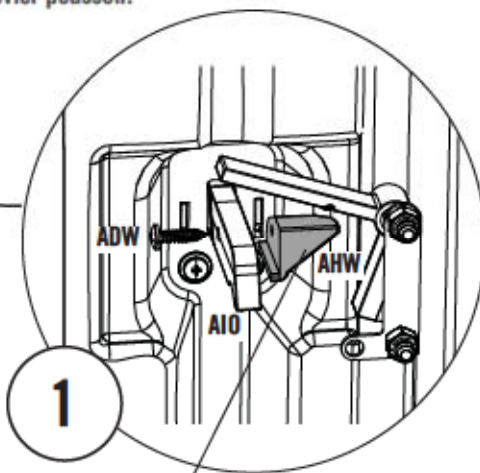

1

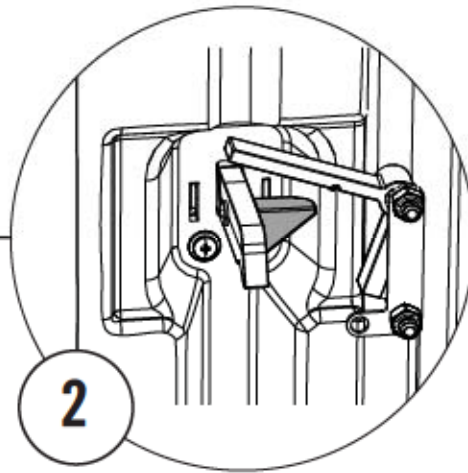

2

The Edge of the Support / El borde de la Palanca de pulgar / Le bord du Levier poussoir

### 5.7

- Attach the **Spring (AHY)** to the Latch (AHV) and Latch Cover Plate (AHX) as shown.
- Sujete el **Resorte (AHY)** al Pestillo (AHV) y a la Placa cubrepestillo (AHX) como se muestra.
- Attachez le **Ressort (AHY)** au Loquet (AHV) et la Plaque protectrice du loquet (AHX) comme illustré.

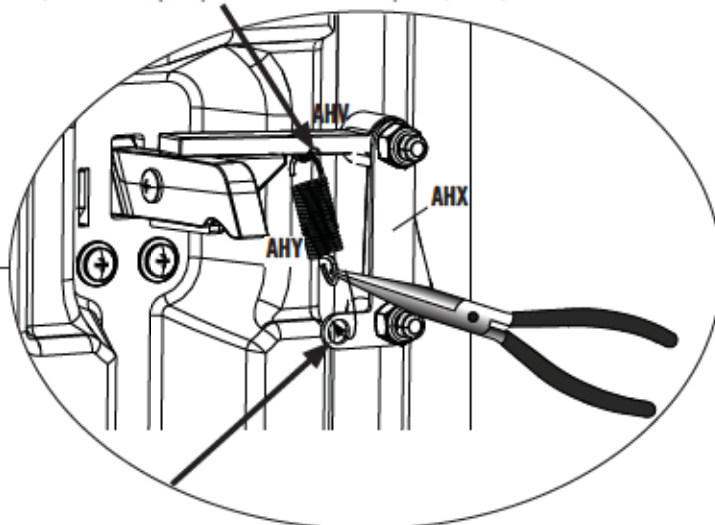

# 6

## DOMED SKYLIGHT ASSEMBLY / ENSAMBLAJE DE LOS TRAGALUCES EN FORMA DE CÚPULA / ASSEMBLAGE DES LUCARNES EN FORME DE DÔME



### HARDWARE REQUIRED / ACCESORIOS REQUERIDOS / ACCESSOIRES REQUIS

Hardware Bags / Bolsas de accesorios / Sacs d'accessoires



EFA (x24)



ADK (x24)



AEE (x48)



AHI (x2)



### PARTS REQUIRED / PIEZAS REQUERIDAS / PIÈCES REQUISES

Plastic Parts / Piezas de plástico / Pièces en plastique

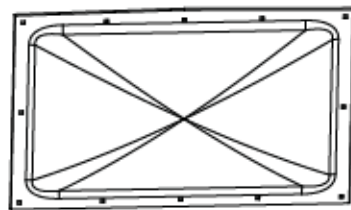

AGB (x2)

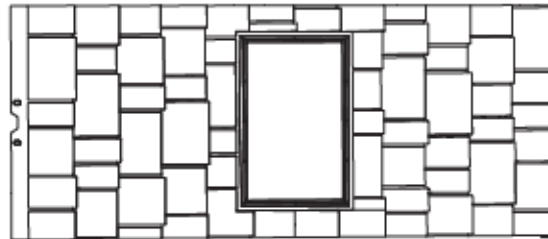

AHB (x2)



### TOOLS REQUIRED / HERRAMIENTAS REQUERIDAS / OUTILS REQUIS



3/8" (10 mm)



## ► SECTION 6 (CONTINUED) / SECCIÓN 6 (SIGUE) / SECTION 6 (SUITE)

TOOLS AND HARDWARE REQUIRED / HERRAMIENTAS Y ACCESORIOS REQUERIDOS / OUTILS ET ACCESSOIRES REQUIS



AHI (x2)

### 6.1

- Remove any excess plastic from the holes along the opening.
- Retire cualquier plástico en exceso de los agujeros a lo largo de la abertura.
- Enlevez de l'excès de plastique des trous le long de l'ouverture.

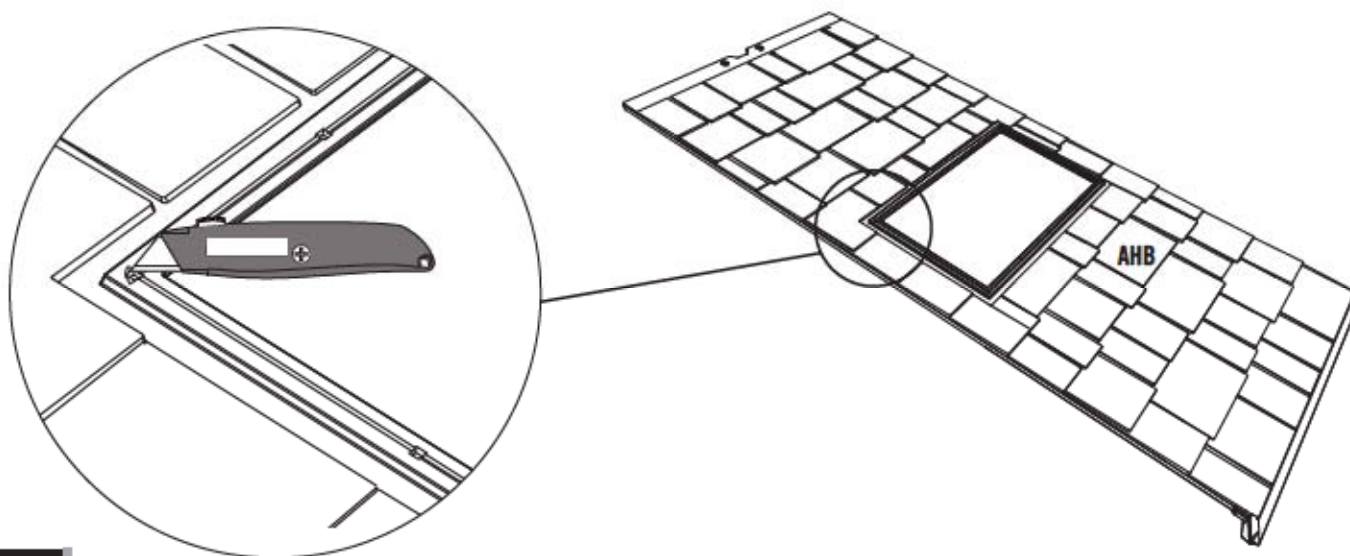

### 6.2

- Lay **Butyl Tape (AHI)** along the groove running along the top edge of the opening of the Panel. Cut the Butyl Tape.
- Coloque la **Cinta de butilo (AHI)** a lo largo de la ranura que corre a lo largo del borde superior de la abertura del Panel. Corte la Cinta de butilo.
- Mettez le **Ruban butylique (AHI)** le long de la rainure qui s'étend le long du bord supérieur de la couverture du Panneau. Coupez le Ruban butylique.

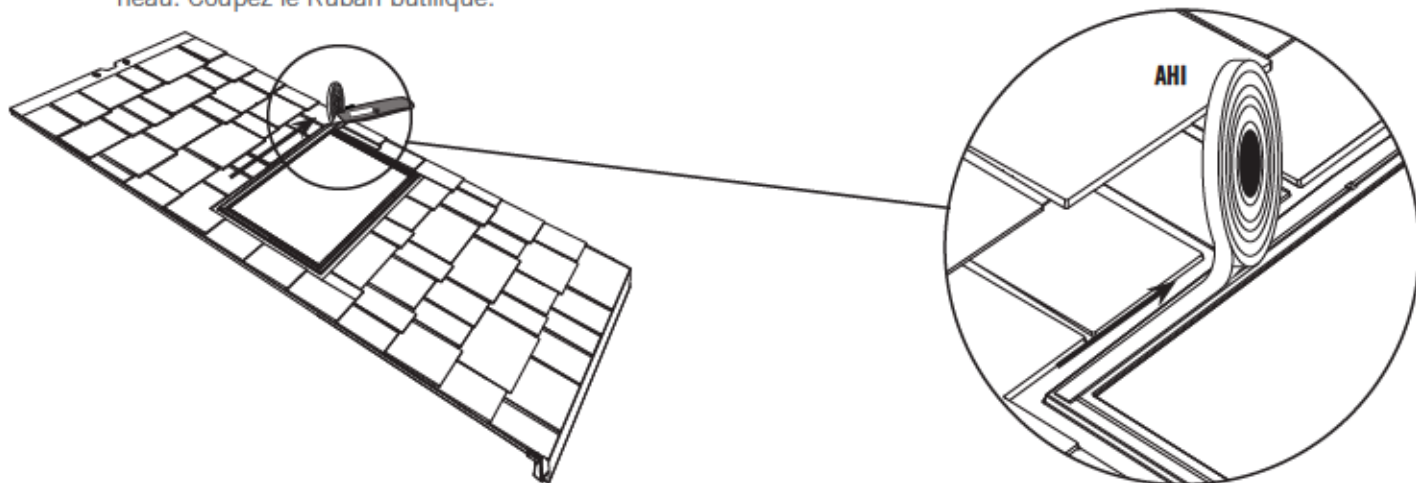

## ► SECTION 6 (CONTINUED) / SECCIÓN 6 (SIGUE) / SECTION 6 (SUITE)

TOOLS AND HARDWARE REQUIRED / HERRAMIENTAS Y ACCESORIOS REQUERIDOS / OUTILS ET ACCESSOIRES REQUIS



AHI (x2)

### 6.3

- **Do not remove any paper backing yet!** Lay **Butyl Tape (AHI)** along the groove running along the right edge of the opening of the Panel. Cut the Tape.
- **¡No retire todavía el papel protector!** Coloque la **Cinta de butilo (AHI)** a lo largo de la ranura que corre a lo largo del borde derecho de la abertura del Panel. Corte la Cinta.
- **Ne pas retirer encore le papier protecteur !** Mettez le **Ruban butylique (AHI)** le long de la rainure qui s'étend le long du bord droit de la couverture du Panneau. Coupez le Ruban.

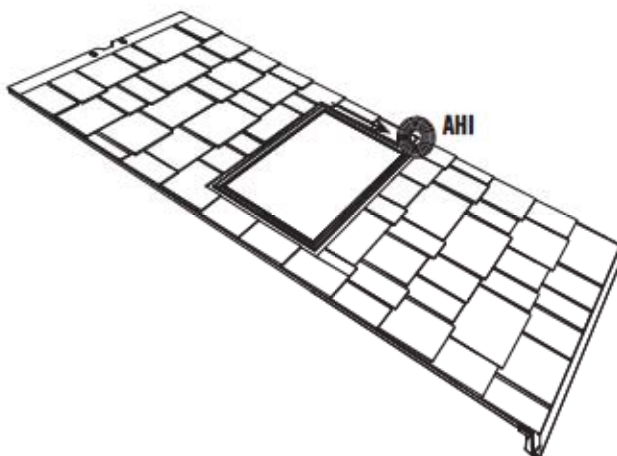

### 6.4

- **Do not remove any paper backing yet!** Lay **Butyl Tape (AHI)** along the groove running along the bottom edge of the opening of the Panel. Cut the Tape.
- **¡No retire todavía el papel protector!** Coloque la **Cinta de butilo (AHI)** a lo largo de la ranura que corre a lo largo del borde inferior de la abertura del Panel. Corte la Cinta.
- **Ne pas retirer encore le papier protecteur !** Mettez le **Ruban butylique (AHI)** le long de la rainure qui s'étend le long du bord inférieur de la couverture du Panneau. Coupez le Ruban.

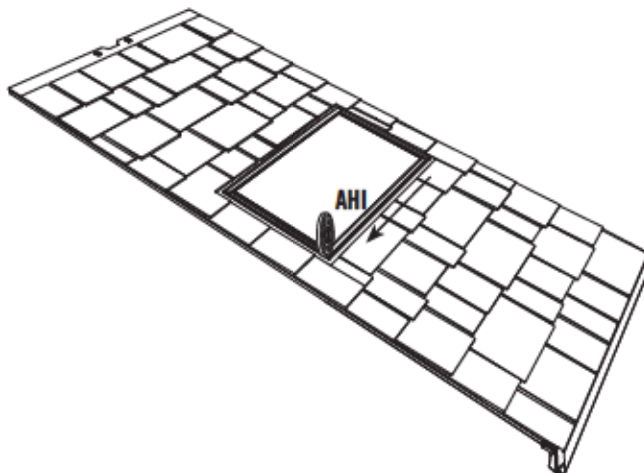

## ► SECTION 6 (CONTINUED) / SECCIÓN 6 (SIGUE) / SECTION 6 (SUITE)

TOOLS AND HARDWARE REQUIRED / HERRAMIENTAS Y ACCESORIOS REQUERIDOS / OUTILS ET ACCESSOIRES REQUIS



AHI (x2)

### 6.5

- **Do not remove any paper backing yet!** Lay **Butyl Tape (AHI)** along the groove running along the left edge of the opening of the Panel. Cut the Tape.
- **¡No retire todavía el papel protector!** Coloque la **Cinta de butilo (AHI)** a lo largo de la ranura que corre a lo largo del borde izquierdo de la abertura del Panel. Corte la Cinta.
- **Ne pas retirer encore le papier protecteur !** Mettez le **Ruban butylique (AHI)** le long de la rainure qui s'étend le long du bord gauche de la couverture du Panneau. Coupez le Ruban.

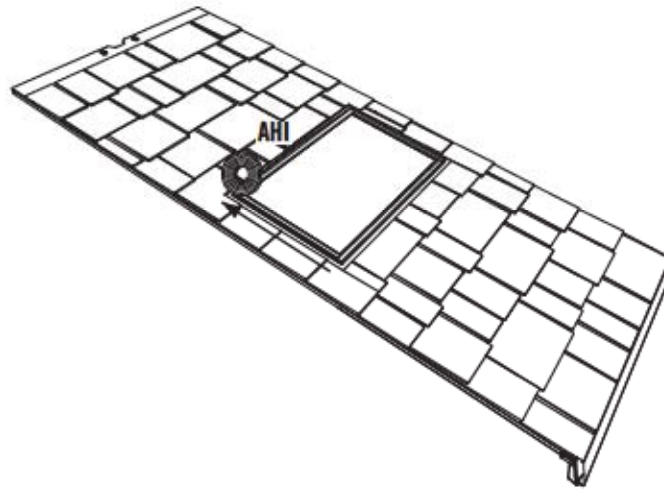

### 6.6

- **Smooth out the Tape to remove any bubbles.** Remove the paper backing. Using a plain screwdriver, poke holes through the Butyl Tape and through the holes in the Roof Panel. The holes in the Roof Panel must remain square.
- **Alise la Cinta para eliminar cualquier burbuja.** Retire el papel protector. Mete un destornillador de punta plana a través de la Cinta butilo y los agujeros cuadrados en el Panel de tejado. Los agujeros en el Panel de tejado deben quedarse cuadrados.
- **Lissez le Ruban pour éliminer des bulles.** Enlevez la pellicule protectrice. Mettez un tournevis plat dans le Ruban butylique et à travers les trous carrés dans le Panneau de toit. Les trous dans le Panneau de toit doivent rester carrés.

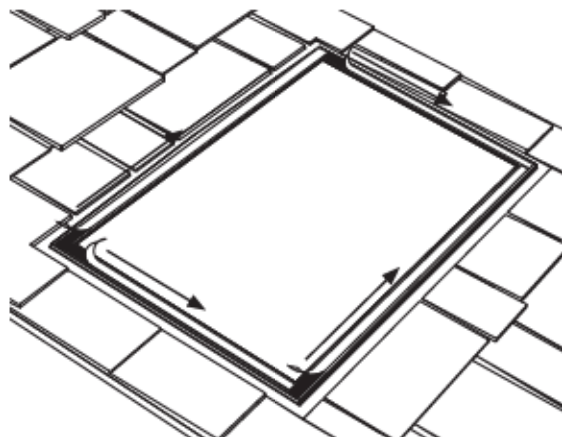

## ► SECTION 6 (CONTINUED) / SECCIÓN 6 (SIGUE) / SECTION 6 (SUITE)

TOOLS AND HARDWARE REQUIRED / HERRAMIENTAS Y ACCESORIOS REQUERIDOS / OUTILS ET ACCESSOIRES REQUIS



3/8"  
(10 mm)



EFA (x24)



ADK (x24)



AEE (x48)

### 6.7

- Remove the protective film from both sides of the **Skylight (AGB)**.
- Retire la capa protectora de los dos caras del **Tragaluz (AGB)**.
- Soulevez la pellicule protectrice des deux côtés de la **Lucarne (AGB)**.

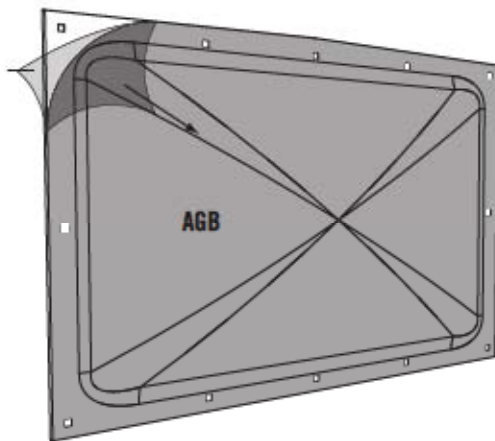

### 6.8

- Align the holes in the Skylight with those in the Panel, and lay the Skylight on the Panel. Press the Skylight onto the Butyl Tape to remove any bubbles.
- Alinee los agujeros en el Tragaluz con ellos en el Panel, y coloque el Tragaluz en el Panel. Empuje el Tragaluz contra la Cinta para eliminar las burbujas.
- alignez les trous dans la Lucarne avec ceux dans le Panneau, et mettez la Lucarne sur le Panneau. Poussez la Lucarne contre le Ruban pour éliminer des bulles.

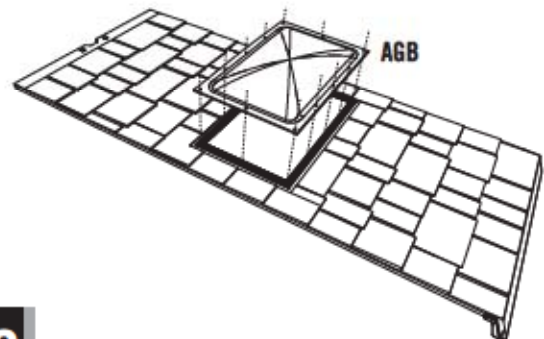

### 6.9

- Secure the Skylight to the Panel using the hardware provided.
- Sujete el Tragaluz al Panel usando los accesorios provistos.
- Attachez la Lucarne au Panneau à l'aide des accessoires fournis.

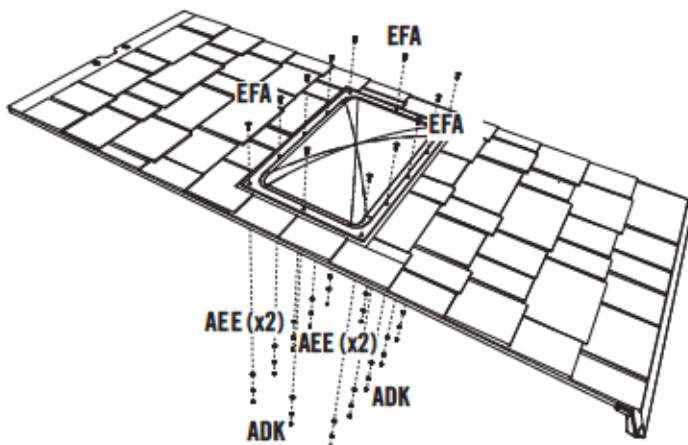

### 6.10

- Repeat this section for the second Domed Skylight.
- Repita esta sección para el segundo Tragaluz en forma de cúpula.
- Répétez cette section pour la deuxième Lucarne en forme de dôme.

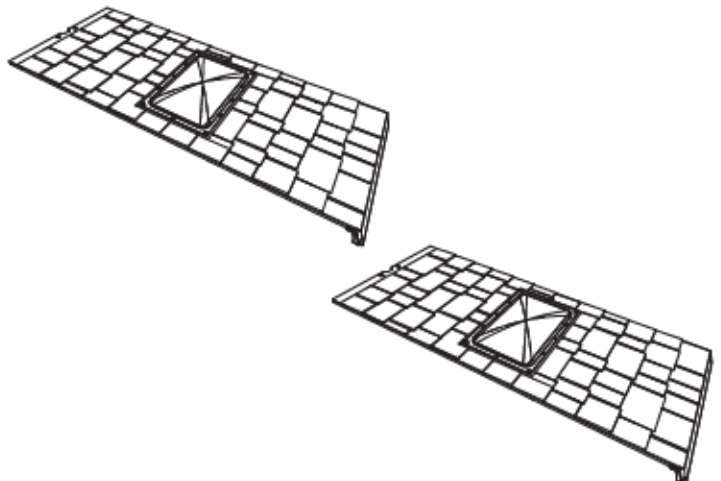

# 7

## FLOOR ASSEMBLY / ENSAMBLAJE DEL PISO / ASSEMBLAGE DU PLANCHER



### HARDWARE REQUIRED / ACCESORIOS REQUERIDOS / ACCESSOIRES REQUIS

*Hardware Bags / Bolsas de accesorios / Sacs d'accessoires*



### PARTS REQUIRED / PIEZAS REQUERIDAS / PIÈCES REQUISES

*Plastic Parts / Piezas de plástico / Pièces en plastique*



**AGJ (x6)**



**AGS (x2)**



**AGT (x2)**



### TOOLS REQUIRED / HERRAMIENTAS REQUERIDAS / OUTILS REQUIS

## ► SECTION 7 (CONTINUED) / SECCIÓN 7 (SIGUE) / SECTION 7 (SUITE)

TOOLS AND HARDWARE REQUIRED / HERRAMIENTAS Y ACCESORIOS REQUERIDOS / OUTILS ET ACCESSOIRES REQUIS



### 7.1



• Hold an **Outer Floor Panel (AGS)** at an angle and slide the tabs along the edge underneath the other **Outer Floor Panel (AGT)**. The tabs interlock. Lay Panel down flat.

• Coloque un **Panel de piso exterior (AGS)** a un ángulo y deslice las lengüetas a lo largo del borde debajo el otro **Panel de piso exterior (AGT)**. Las lengüetas se entrelazan las unas con las otras. Aplane el Panel.

• Posez un **Panneau de plancher extérieur (AGS)** à un angle et glissez les languettes le long du bord au-dessus de l'autre **Panneau de plancher extérieur (AGT)**. Les languettes s'enclenchent les uns les autres. Étendez-le par terre.

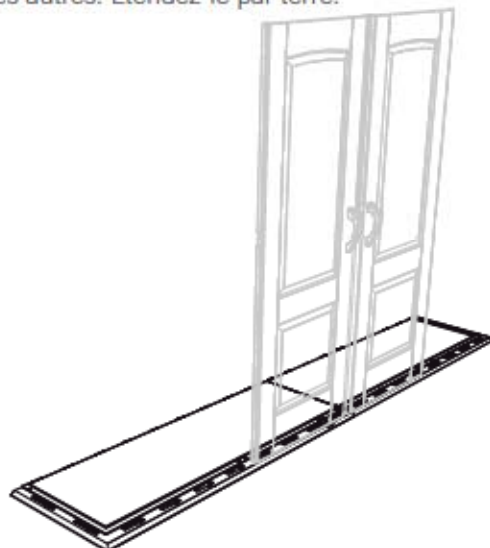
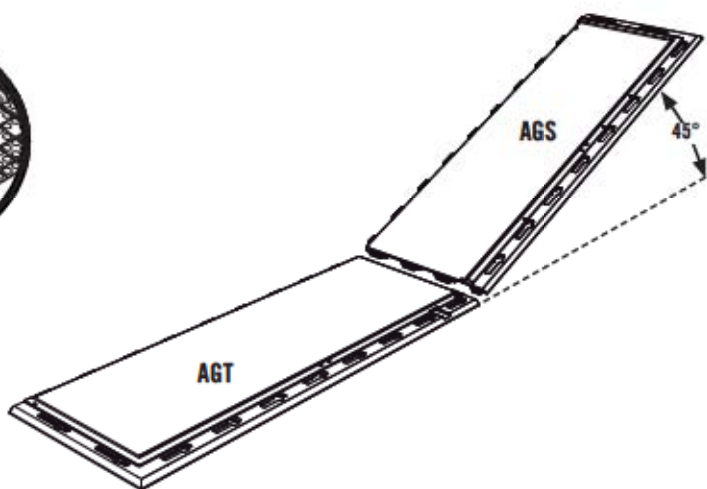

### 7.2

• Join two **Inner Floor Panels (AGJ)**. Then, slide the tabs along the edge underneath the first two Outer Floor Panels. The tabs interlock. Lay the Panels down flat.

• Junte dos **Paneles de piso interiores (AGJ)**. Entonces, deslice las lengüetas a lo largo del borde debajo los otros Paneles de piso exteriores. Las lengüetas se entrelazan las unas con las otras. Aplane los Paneles.

• Attachez deux **Panneaux de plancher intérieurs (AGJ)**. Ensuite, glissez les languettes le long du bord au-dessus des autres **Panneaux de plancher extérieurs**. Les languettes s'enclenchent les uns les autres. Étendez-les par terre.

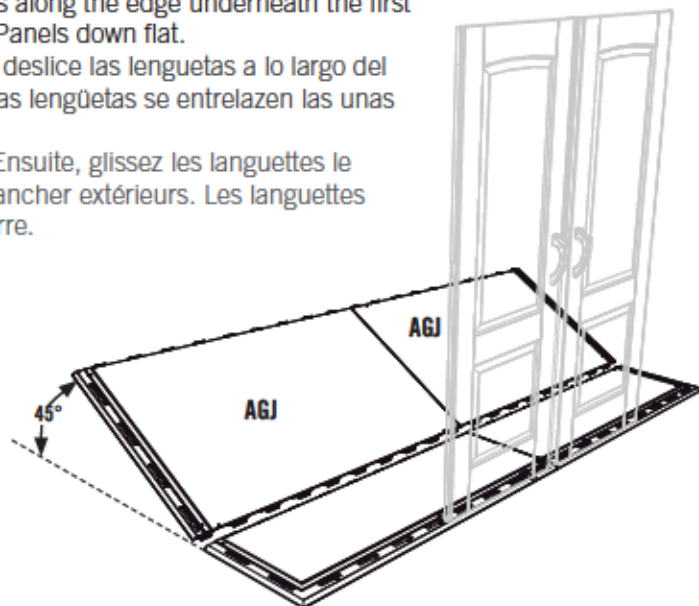
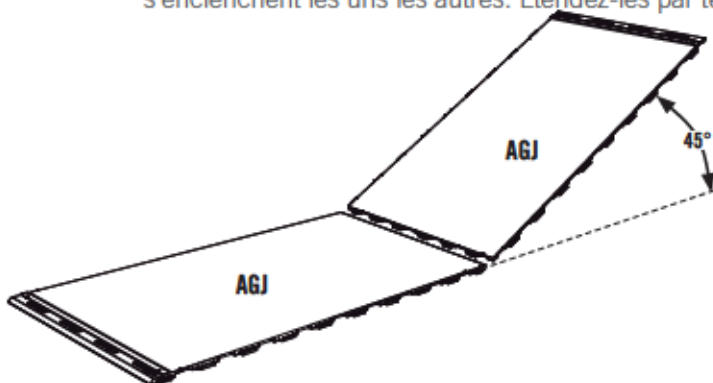

## ► SECTION 7 (CONTINUED) / SECCIÓN 7 (SIGUE) / SECTION 7 (SUITE)

TOOLS AND HARDWARE REQUIRED / HERRAMIENTAS Y ACCESORIOS REQUERIDOS / OUTILS ET ACCESSOIRES REQUIS



### 7.3

- Continue joining two **Inner Floor Panels (AGJ)** and connecting them to the previous Panels. Lay the Panels down flat.
- Continúe a juntar dos **Paneles de piso interiores (AGJ)** y a conectarlo a los Paneles anteriores. Aplane los Paneles.
- Continuez à assembler deux **Panneaux de plancher intérieurs (AGJ)** et à attacher les Panneaux aux Panneaux précédents. Étendez-les par terre.

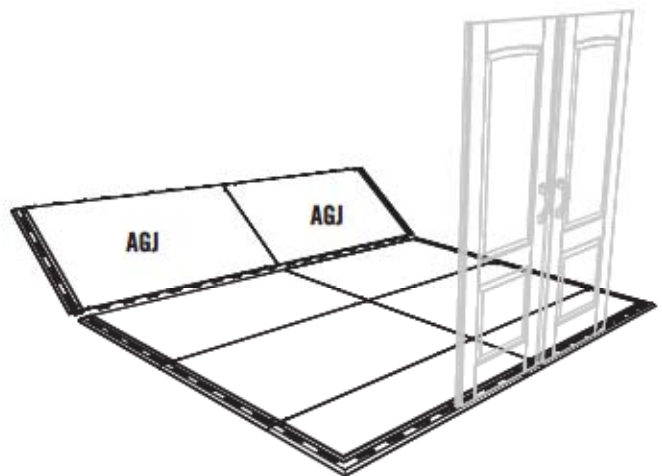
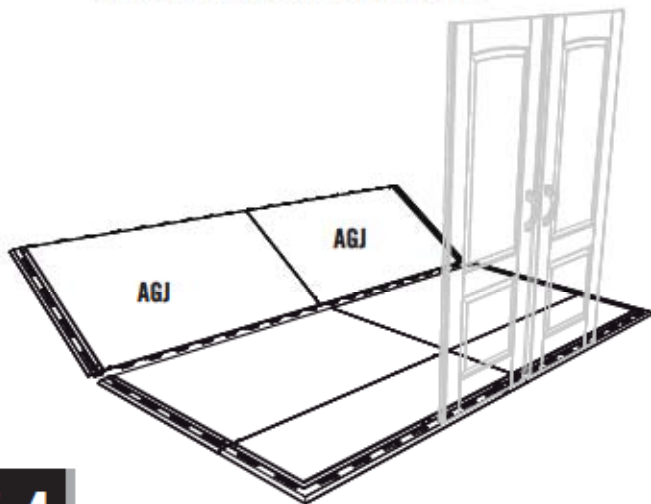

### 7.4

- Repeat the first step to join two more **Outer Floor Panels (AGS & AGT)**. Then, slide the tabs along the edge underneath the last two Inner Floor Panels. Lay the Panels down flat.
- Repita el primer paso para unir dos más **Paneles de piso exteriores (AGS & AGT)**. Entonces, deslice las lenguetas a lo largo del borde debajo los otros Paneles de piso exteriores. Aplane los Paneles.
- Répétez la première étape pour assembler deux plus **Panneaux de plancher extérieurs (AGS & AGT)**. Ensuite, glissez les languettes le long du bord au-dessus des autres Panneaux de plancher extérieurs. Étendez-les par terre.

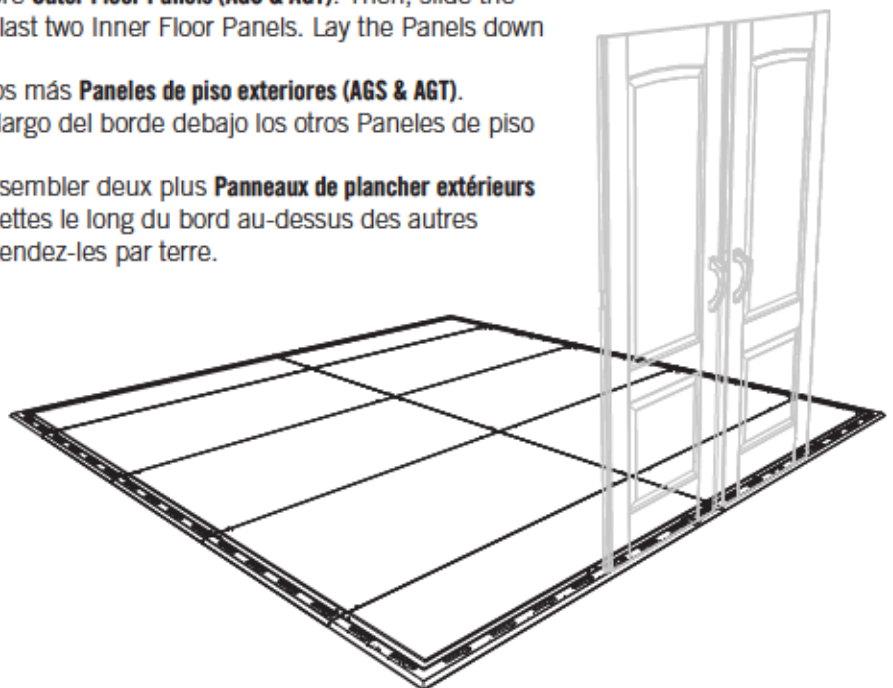
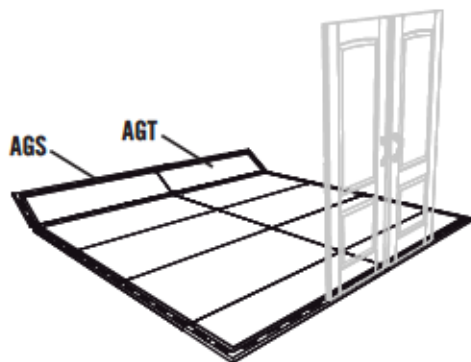

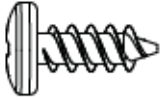

**HARDWARE REQUIRED / ACCESORIOS REQUERIDOS / ACCESSOIRES REQUIS**

Hardware Bags / Bolsas de accesorios / Sacs d'accessoires

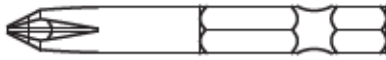

ADZ (x116)



ADC (x1)

**PARTS REQUIRED / PIEZAS REQUERIDAS / PIÈCES REQUISES**

Metal Parts / Piezas de metal / Pièces en métal

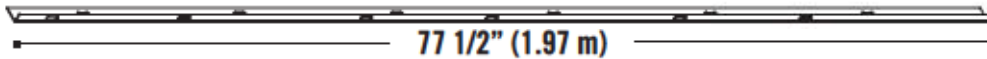

AFR (x4)



Plastic Parts / Piezas de plástico / Pièces en plastique

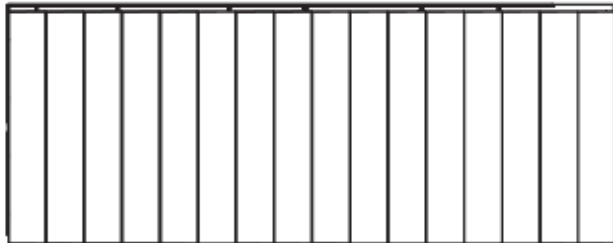

AHD (x12)

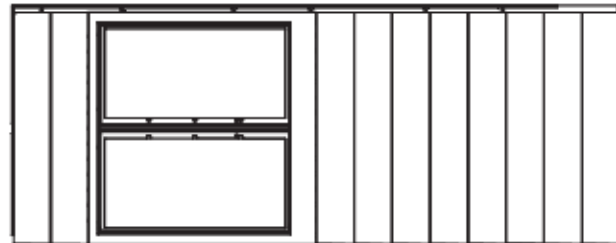

AHH (x2)

**TOOLS REQUIRED / HERRAMIENTAS REQUERIDAS / OUTILS REQUIS**

## ► SECTION 8 (CONTINUED) / SECCIÓN 8 (SIGUE) / SECTION 8 (SUITE)

TOOLS AND HARDWARE REQUIRED / HERRAMIENTAS Y ACCESORIOS REQUERIDOS / OUTILS ET ACCESSOIRES REQUIS



### 8.1



- Insert the tabs at the bottom of the **Wall Panel (AHD)** into the four slots along the front, right corner of the Floor.
- Introduzca las lengüetas al borde inferior del **Panel mural (AHD)** en las cuatro ranuras a lo largo de la esquina delantera derecha del Piso.
- Insérez les languettes au bord inférieur du **Panneau mural (AHD)** dans les quatre rainures le long du coin avant droit du Plancher.

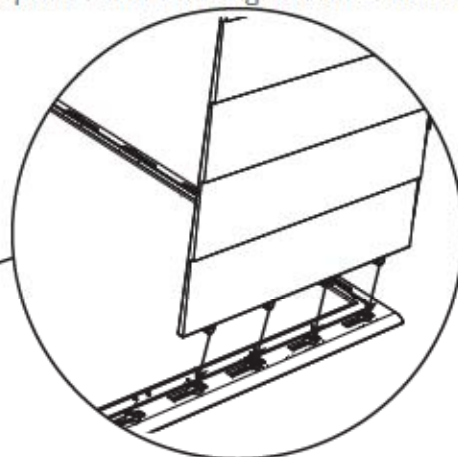
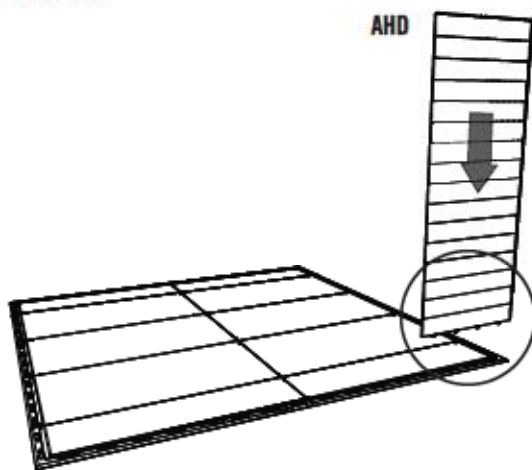

### 8.2

- Slide the Wall Panel to the left.
- Deslice el Panel mural a la izquierda.
- Faites glisser le Panneau mural à gauche.

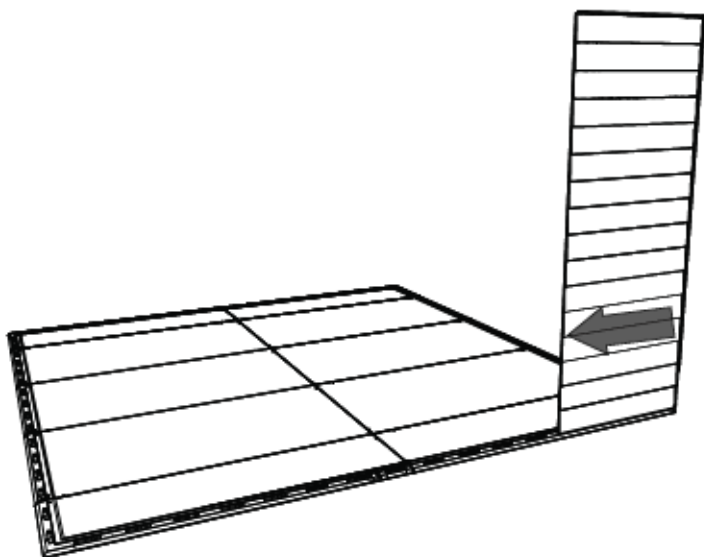

### 8.3

- Repeat the previous steps for the first Wall Panel along the right side of the Floor.
- Repita los pasos anteriores para el primer Panel mural a lo largo del borde derecho del Piso.
- Répétez les étapes précédentes pour le premier Panneau mural le long du bord droit du Plancher.

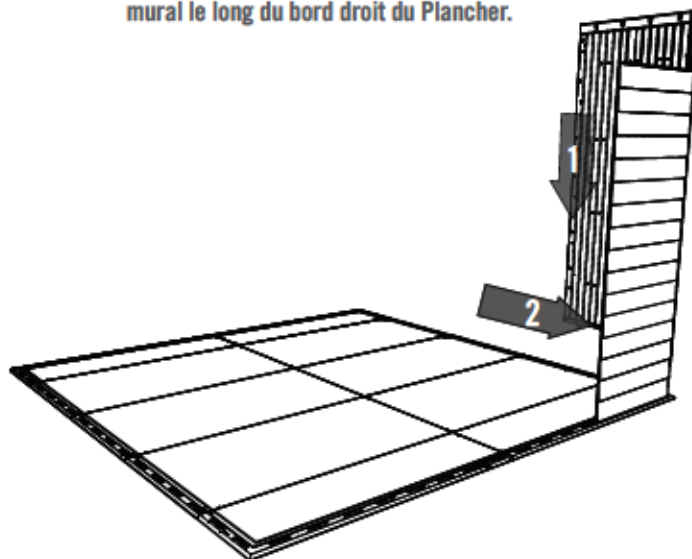

## ► SECTION 8 (CONTINUED) / SECCIÓN 8 (SIGUE) / SECTION 8 (SUITE)

TOOLS AND HARDWARE REQUIRED / HERRAMIENTAS Y ACCESORIOS REQUERIDOS / OUTILS ET ACCESSOIRES REQUIS

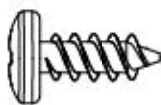

ADZ (x30)

### 8.4

- Align the holes in a **Corner Channel (AFR)** with the holes where the two Panels connect. Attach the Corner Channel to the Panels using the required hardware. **This step is done for each corner.**
- Alinee los agujeros en un **Canal angular (AFR)** con los agujeros a lo largo de los dos Paneles que forman l'angle. Sujete el Canal angular a los Paneles usando los elementos requeridos. **Se hace este paso para cada esquina.**
- Alignez les trous dans le **Canal angulaire (AFR)** avec les trous le long des bords des deux Panneaux qui forment l'encoignure. Attachez le Canal angulaire aux Panneaux à l'aide des accessoires requis. **Il faut faire cette étape pour chaque coin.**

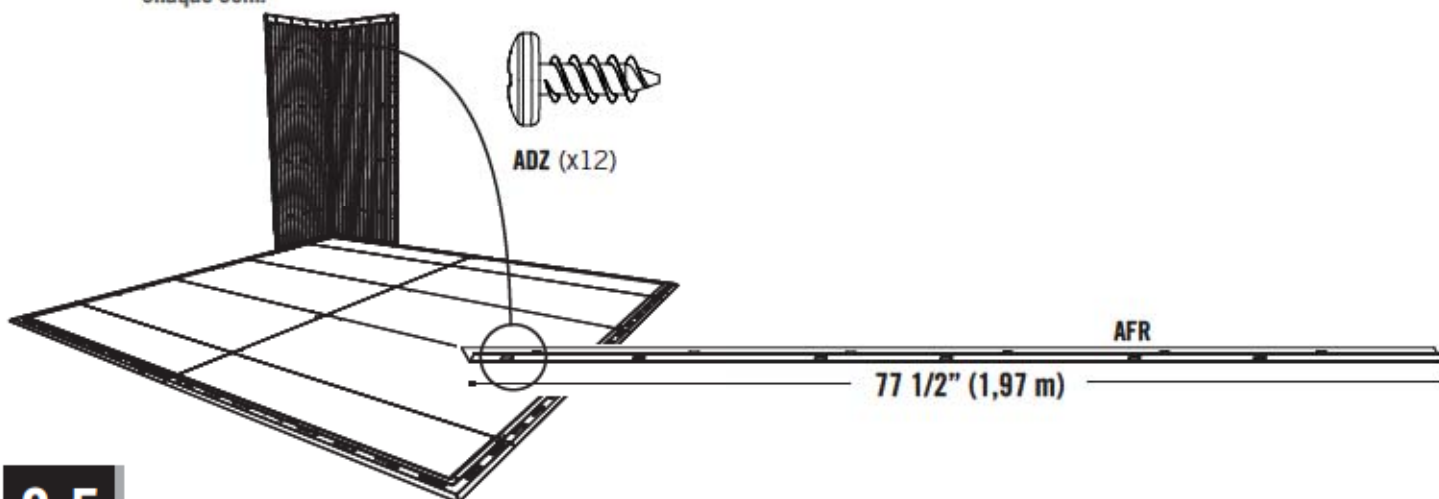

### 8.5

- One by one, insert the **Wall Panels (AHD & AHH)** into the slots along the right side of the Floor, and then slide them toward the front. **The Window Wall Panel may be placed in any non-corner position along the sides of the shed.** Secure the Panels to one another using six (6) **Screws (ADZ)** at each union.
- Uno por uno, inserte los **Paneles murales (AHD & AHH)** en las ranuras a lo largo del borde derecho del Piso, y entonces deslícelos hacia el borde delantero. **Se puede insertar el Panel mural para la ventana en cualquier posición, salvo las esquinas, a lo largo de los bordes laterales.** Sujete los Paneles entre sí usando seis (6) **Tornillos (ADZ)** a cada junta.
- Un par un, insérez les **Panneaux muraux (AHD & AHH)** dans les fentes le long du bord droit du Plancher, et ensuite glissez-les vers le bord avant. **Vous pouvez insérer le Panneau mural à fenêtre dans quiconque emplacement, sauf les encoignures, le long des bords latéraux.** Attachez les Panneaux les un aux autres à l'aide de six (6) **Vis (ADZ)** à chaque jointure.

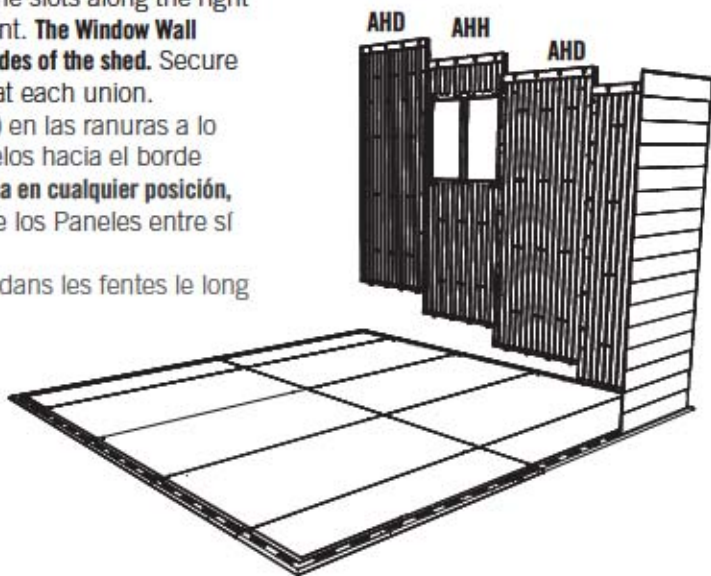

## ► SECTION 8 (CONTINUED) / SECCIÓN 8 (SIGUE) / SECTION 8 (SUITE)

TOOLS AND HARDWARE REQUIRED / HERRAMIENTAS Y ACCESORIOS REQUERIDOS / OUTILS ET ACCESSOIRES REQUIS

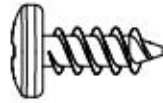

ADZ (x30)

### 8.6

- Secure the two corner Panels together using a **Corner Channel (AFR)** and twelve (12) **Screws (ADZ)**.
- Sujete los dos Paneles entre sí usando un **Canal angular (AFR)** y doce (12) **Tornillos (ADZ)**.
- Attachez les deux Panneaux l'un à l'autre à l'aide d'un **Canal angulaire (AFR)** et douze (12) **Vis (ADZ)**.

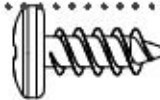

ADZ (x12)

AHD

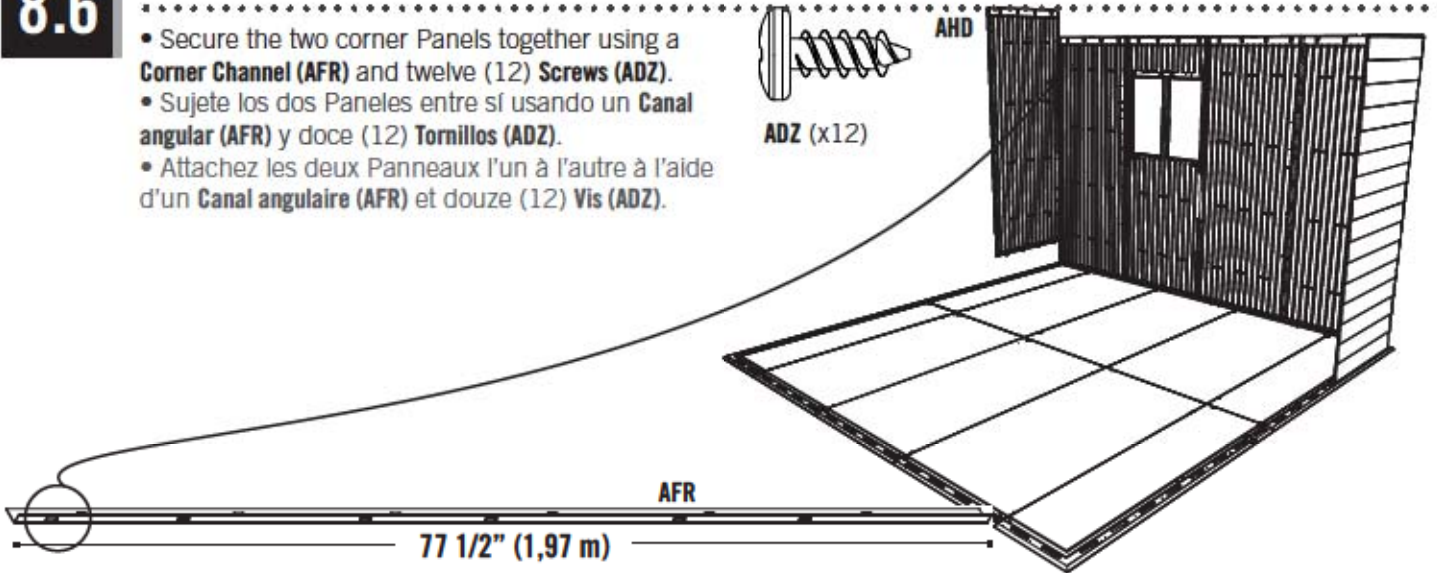

### 8.7

- Starting at the right, attach the next three Wall Panels along the rear of the Floor, and secure them together using six (6) **Screws (ADZ)** at each seam.
- Empezando al lado derecho, sujete los próximos tres Paneles murales a lo largo del borde trasero del Piso, y sujételos usando seis (6) **Tornillos (ADZ)** a cada juntura.
- En commençant au côté droit, attachez les trois Panneaux muraux suivants le long du bord arrière du Plancher. Attachez les Panneaux les uns aux autres à l'aide de six (6) **Vis (ADZ)** à chaque jointure.

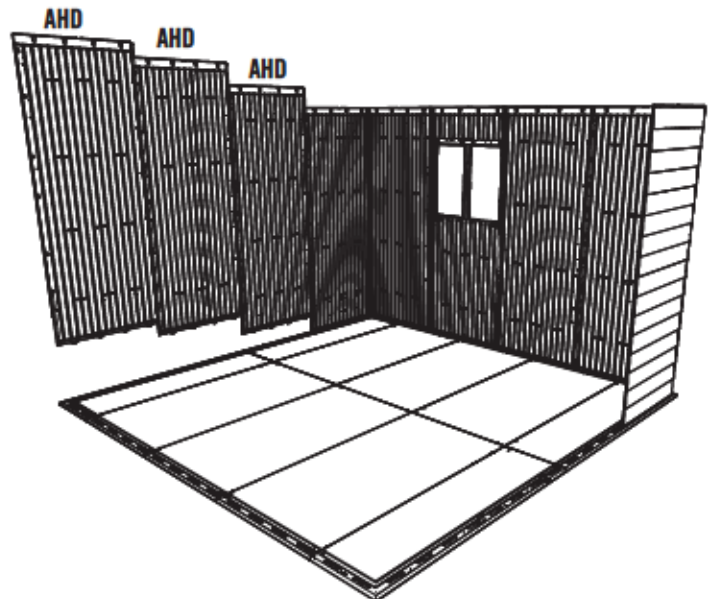

## ► SECTION 8 (CONTINUED) / SECCIÓN 8 (SIGUE) / SECTION 8 (SUITE)

TOOLS AND HARDWARE REQUIRED / HERRAMIENTAS Y ACCESORIOS REQUERIDOS / OUTILS ET ACCESSOIRES REQUIS



ADZ (x42)

### 8.8

- Insert the tabs at the bottom of a Wall Panel into the four slots along the left edge of the Floor, and slide the Panel to the rear. Secure the two corner Panels together using a **Corner Channel (AFR)** and twelve (12) **Screws (ADZ)**.
- Introduzca las lengüetas al borde inferior de un Panel mural en las cuatro ranuras a lo largo del borde izquierdo del Piso, y deslice el Panel hacia atrás. Sujete los dos Paneles de la entre sí usando un **Canal angular (AFR)** y doce (12) **Tornillos (ADZ)**.
- Insérez les languettes au bord inférieur du Panneau mural dans les quatre rainures le long du bord gauche du Plancher, et glissez le Panneau vers l'arrière du Plancher. Attachez les deux Panneaux du coin l'un à l'autre à l'aide d'un **Canal angulaire (AFR)** et douze (12) **Vis (ADZ)**.

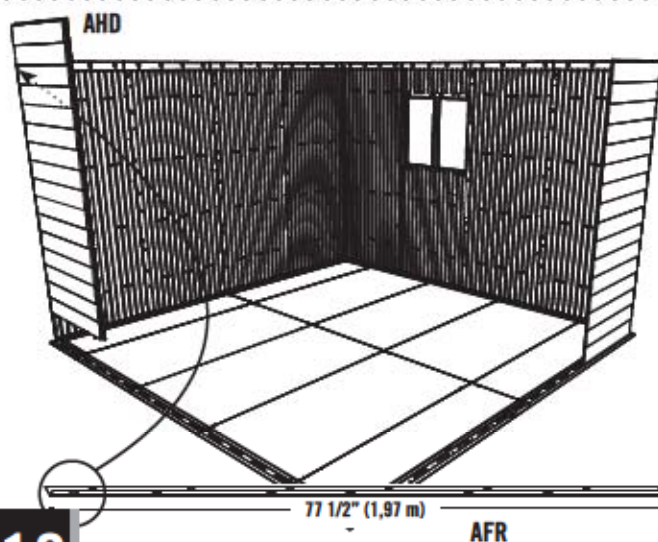

### 8.9

- Attach these **Wall Panels (AHD & AHH)** to the Floor. **The Window Wall Panel may be placed in any non-corner position along the sides of the shed.** Secure the Panels together.
- Sujete estos **Paneles murales (AHD & AHH)** al Piso. **Se puede insertar el Panel mural para la ventana en cualquier posición, salvo las esquinas, a lo largo de los bordes laterales.** Sujete los Paneles los entre sí.
- Attachez ces **Panneaux muraux (AHD & AHH)** au Plancher. **Vous pouvez insérer le Panneau mural à fenêtre dans quiconque emplacement, sauf les encoignures, le long des bords latéraux.** Attachez les Panneaux les un aux autres.

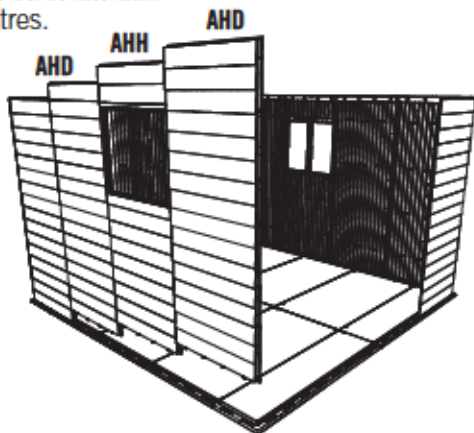

### 8.10

- Attach the last Wall Panel to the Floor, and secure the two corner Panels together using a **Corner Channel (AFR)** and twelve (12) **Screws (ADZ)**.
- Sujete el último Panel mural al Piso, y sujete los dos Paneles usando un **Canal angular (AFR)** y doce (12) **Tornillos (ADZ)**.
- Attachez le dernier Panneau mural au Plancher, et attachez les deux Panneaux l'aide d'un **Canal angulaire (AFR)** et douze (12) **Vis (ADZ)**.

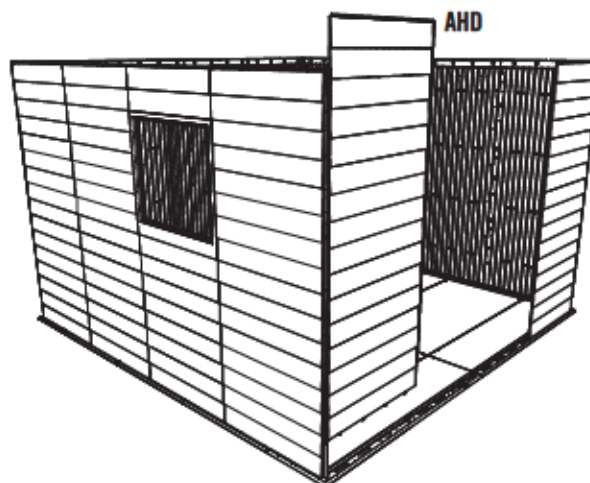



HARDWARE REQUIRED / ACCESORIOS REQUERIDOS / ACCESSOIRES REQUIS

Hardware Bag / Bolsa de accesorios / Sac d'accessoires

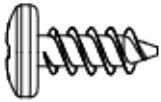

ADZ (x112)

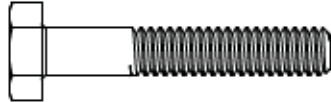

AAK (x18)



ADJ (x18)



AHT (x6)



PARTS REQUIRED / PIEZAS REQUERIDAS / PIÈCES REQUISES

Metal Parts / Piezas de metal / Pièces en métal

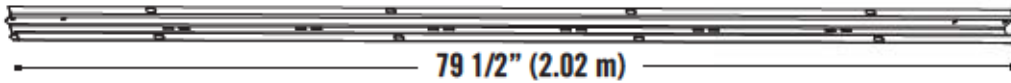

AFQ (x6)

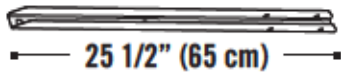

AFJ (x2)

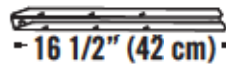

AFN (x4)

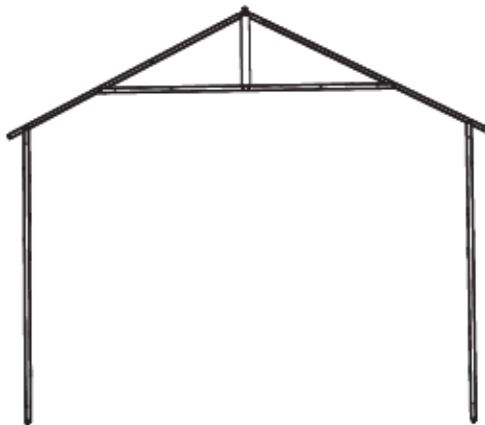

(x4)



TOOLS REQUIRED / HERRAMIENTAS REQUERIDAS / OUTILS REQUIS



7/16" (11 mm) (x2)

## ► SECTION 9 (CONTINUED) / SECCIÓN 9 (SIGUE) / SECTION 9 (SUITE)

TOOLS AND HARDWARE REQUIRED / HERRAMIENTAS Y ACCESORIOS REQUERIDOS / OUTILS ET ACCESSOIRES REQUIS

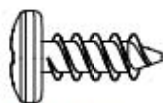

ADZ (x60)

### 9.1

- One by one, place the four (4) Trusses in the centers of opposite Wall Panels (Regular and Window). Align the holes, and secure with eight (8) **Screws (ADZ)** per Truss for a regular Wall Panel and six (6) **Screws (ADZ)** per Truss on a Window Wall Panel.
- Uno por uno, coloque los cuatro (4) Armazones en los centros de los Paneles murales opuestos (los normales y los para las ventanas). Alinee los agujeros, y sujételos usando ocho (8) **Tornillos (ADZ)** por Armazón para un Panel mural normal y seis (6) **Tornillos (ADZ)** por Armazón para un Panel mural para la ventana.
- Un par un, mettez les quatre (4) Fermes aux centres des Panneaux muraux opposés (les normaux et ceux pour la fenêtre). Alignez les trous, et attachez les Fermes aux Panneaux à l'aide de huit (8) **Vis (ADZ)** par Ferme pour un Panneau mural normal et six (6) **Vis (ADZ)** pour les Panneaux muraux pour la fenêtre.

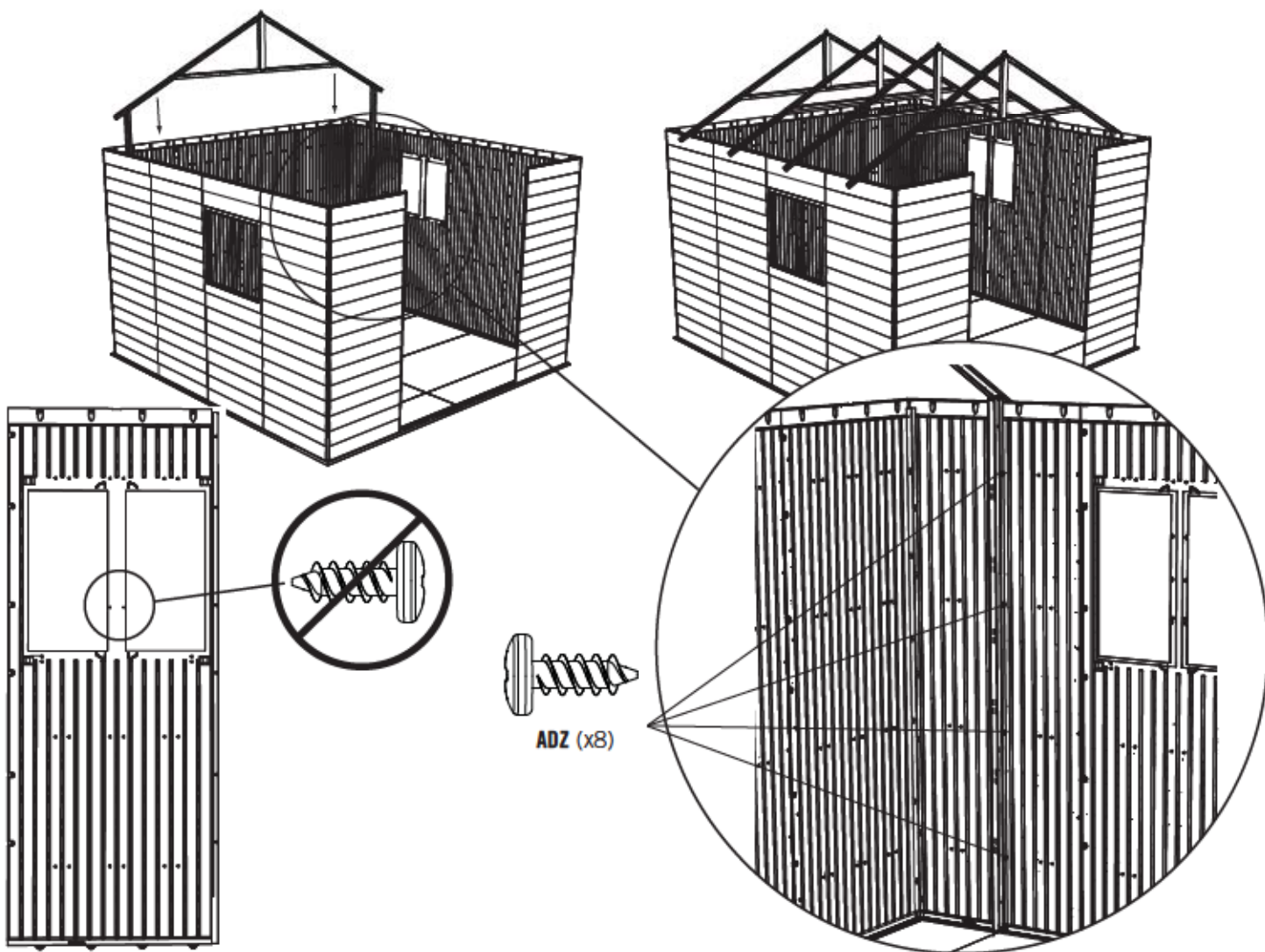

## ► SECTION 9 (CONTINUED) / SECCIÓN 9 (SIGUE) / SECTION 9 (SUITE)

TOOLS AND HARDWARE REQUIRED / HERRAMIENTAS Y ACCESORIOS REQUERIDOS / OUTILS ET ACCESSOIRES REQUIS



7/16" (x2)  
11 mm (x2)

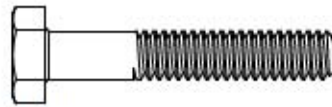

AAK (x12)



ADJ (x12)

### 9.2

- Place a **Short Wall Channel Extension (AFN)** into the top of the Wall Channel. Secure with two (2) **Bolts (AAK)** and two (2) **Cap Nuts (ADJ)**. **Do not overtighten.**
- Coloque una **Extensión corta para el soporte mural (AFN)** dentro del extremo superior del Soporte mural. Sujételo usando dos (2) **Pernos (AAK)** y dos (2) **Tuercas ciegas (ADJ)**. **No apriete demasiado.**
- Insérez un **Rallonge court pour le support mural (AFN)** dans l'extrémité supérieure du Support mural. Attachez-le au Support à l'aide de deux (2) **Boulons (AAK)** et deux (2) **Écrous à chape (ADJ)**. **Ne pas trop serrer.**

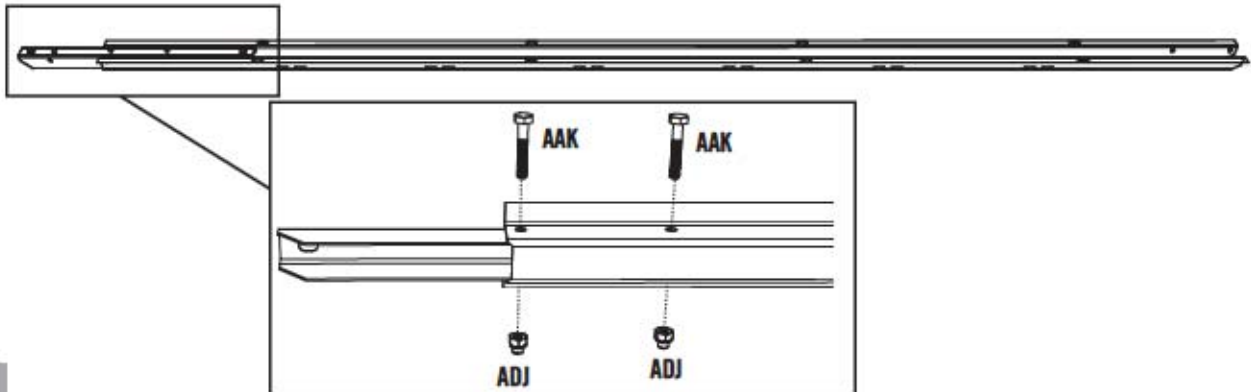

### 9.3

- Repeat this step three times.
- Repita este paso tres veces.
- Répétez cette étape trois fois.

## ► SECTION 9 (CONTINUED) / SECCIÓN 9 (SIGUE) / SECTION 9 (SUITE)

TOOLS AND HARDWARE REQUIRED / HERRAMIENTAS Y ACCESORIOS REQUERIDOS / OUTILS ET ACCESSOIRES REQUIS



7/16" (x2)  
11 mm (x2)

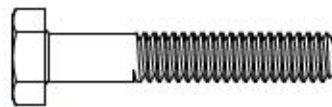

AAK (x12)



ADJ (x12)

### 9.4

- Place a **Long Wall Channel Extension (AFJ)** into the top of the Wall Channel. Secure with two (2) **Bolts (AAK)** and two (2) **Cap Nuts (ADJ)**. **Do not overtighten.**
- Coloque una **Extensión larga para el soporte mural (AFJ)** dentro del extremo superior del Soporte mural. Sujételo usando dos (2) **Pernos (AAK)** y dos (2) **Tuercas ciegas (ADJ)**. **No apriete demasiado.**
- Insérez un **Rallonge long pour le support mural (AFJ)** dans l'extrémité supérieure du Support mural. Attachez-le au Support à l'aide de deux (2) **Boulons (AAK)** et deux (2) **Écrous à chape (ADJ)**. **Ne pas trop serrer.**

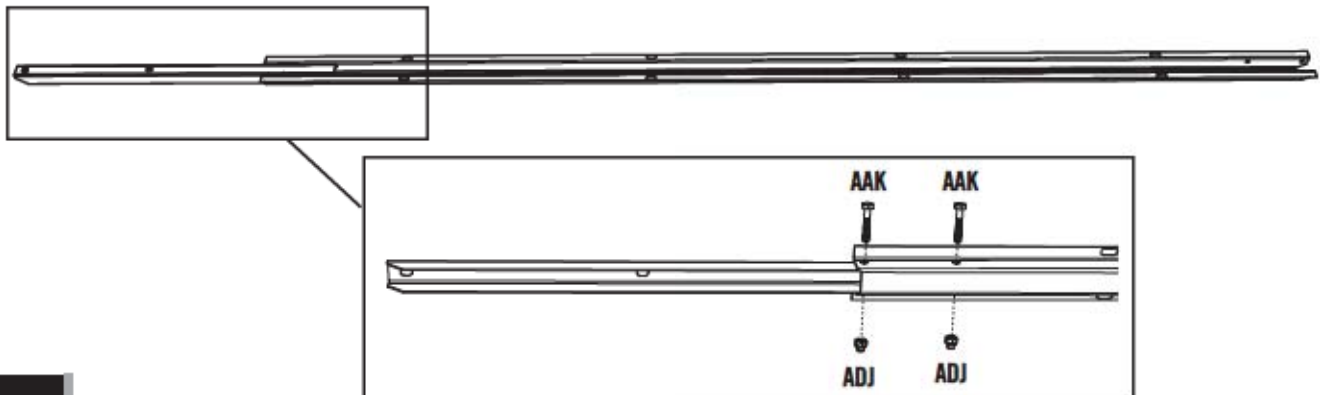

### 9.5

- **Repeat the last step one time.**
- **Repita este paso anterior una vez.**
- **Répétez l'étape précédente une fois.**

## ► SECTION 9 (CONTINUED) / SECCIÓN 9 (SIGUE) / SECTION 9 (SUITE)

TOOLS AND HARDWARE REQUIRED / HERRAMIENTAS Y ACCESORIOS REQUERIDOS / OUTILS ET ACCESSOIRES REQUIS



7/16" (x2)  
11 mm (x2)

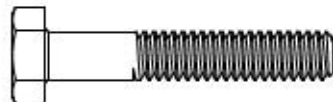

AAK (x6)



ADJ (x6)



AHT (x6)

### 9.6

- Secure a **Floor Bracket (AHT)** to the bottom of the Wall Channel using one (1) **Bolt (AAK)** and one (1) **Cap Nut (ADJ)**. **Do not overtighten.**
- Sujete un **Soporte del piso (AHT)** al extremo inferior del Soporte mural usando un (1) **Perno (AAK)** y una (1) **Tuerca ciega (ADJ)**. **No apriete demasiado.**
- Attachez **Support de plancher (AHT)** à l'extrémité inférieure du Support mural à l'aide d'un (1) **Boulon (AAK)** et un (1) **Écrou à chape (ADJ)**. **Ne pas trop serrer.**

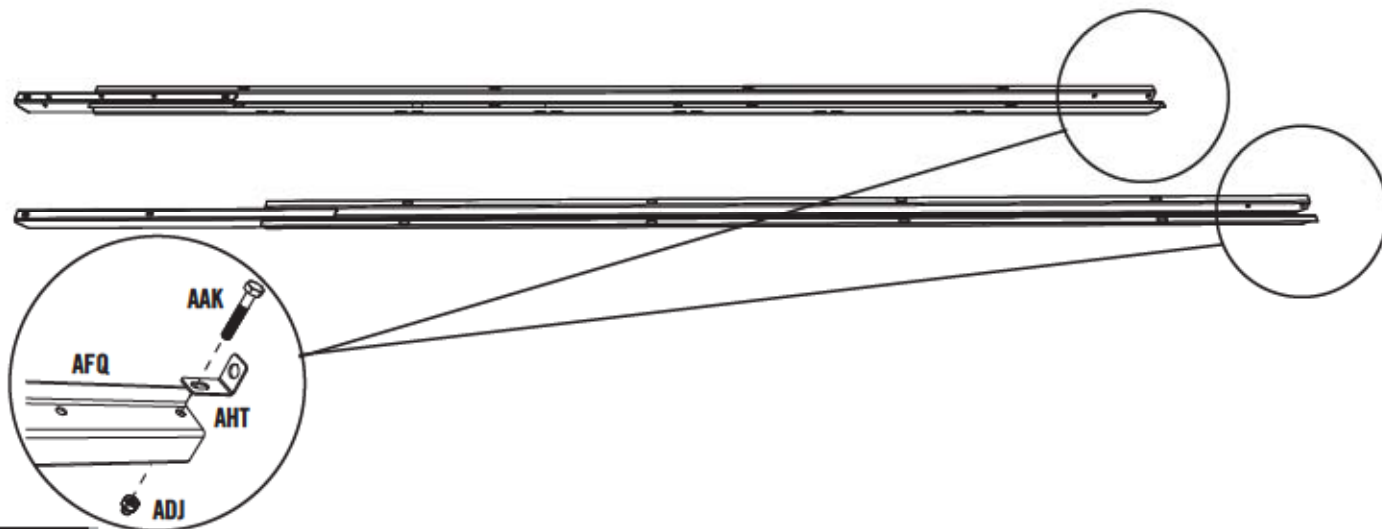

### 9.7

- Repeat the last step five times.
- Repita el paso anterior cinco veces.
- Répétez l'étape précédente cinq fois.

## ► SECTION 9 (CONTINUED) / SECCIÓN 9 (SIGUE) / SECTION 9 (SUITE)

TOOLS AND HARDWARE REQUIRED / HERRAMIENTAS Y ACCESORIOS REQUERIDOS / OUTILS ET ACCESSOIRES REQUIS

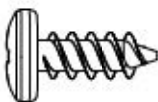

ADZ (x16)

### 9.8

#### FRONT WALL PANELS / PANELES MURALES DELANTEROS / PANNEAUX MURAUX AVANTS

- Secure a Wall Support Channel (with a Short Extension) to each of the front, corner Wall Panels as shown. **Do not overtighten.**
- Sujete un Soporte mural (con una Extensión corta) a cada Panel mural delantero como se muestra. **No apriete demasiado.**
- Attachez un Support mural (avec un Rallonge court) à chaque Panneau mural avant comme illustré. **Ne pas trop serrer.**

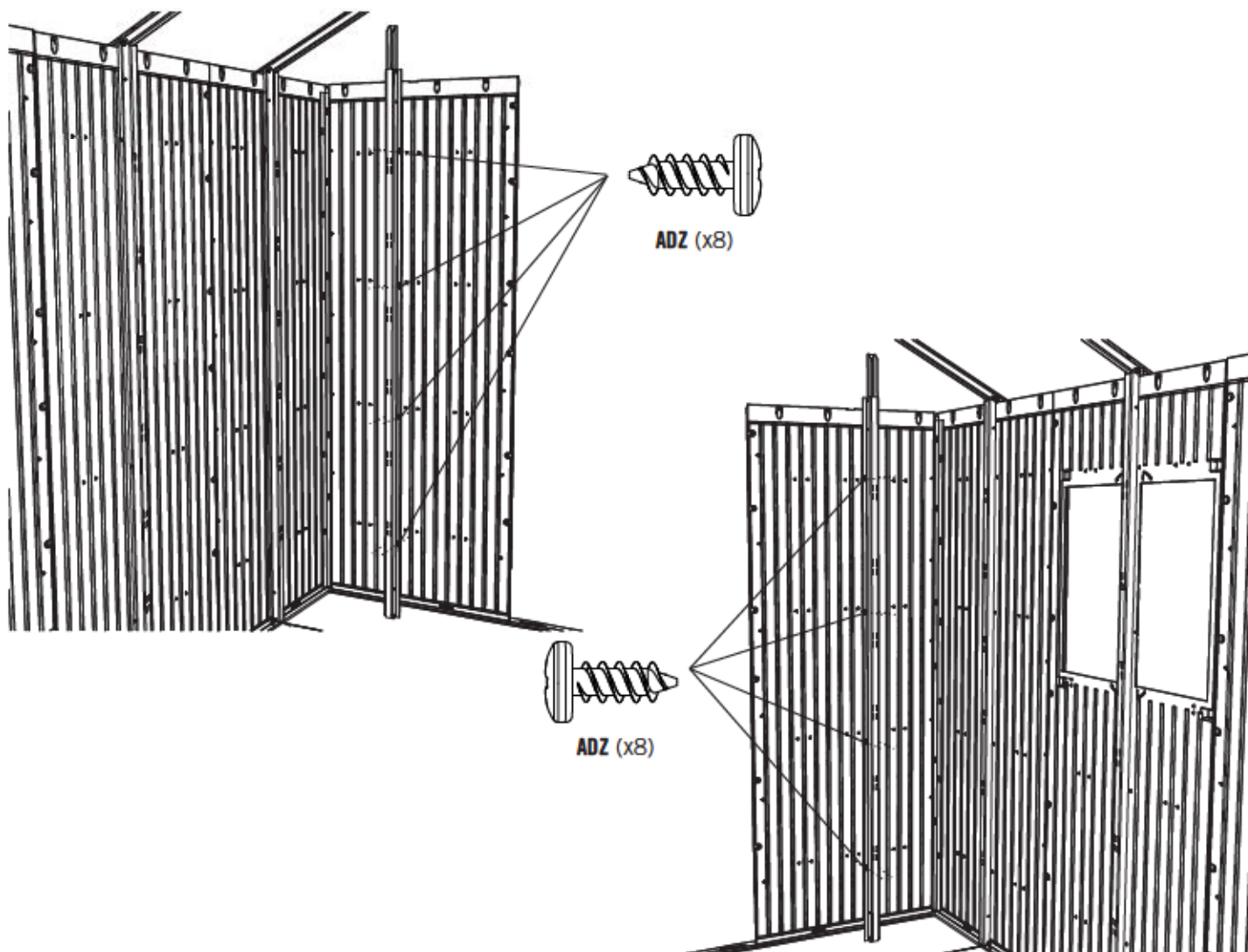

## ► SECTION 9 (CONTINUED) / SECCIÓN 9 (SIGUE) / SECTION 9 (SUITE)

TOOLS AND HARDWARE REQUIRED / HERRAMIENTAS Y ACCESORIOS REQUERIDOS / OUTILS ET ACCESSOIRES REQUIS

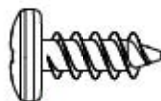

ADZ (x32)

### 9.9

#### REAR WALL PANELS / PANELES MURALES TRASEROS / PANNEAUX MURAUX ARRIÈRES

- Secure a Wall Support Channel (with a Short Extension) to each of the rear, corner Wall Panels as shown. **Do not overtighten.** Secure a Wall Support Channel (with a Long Extension) to each of the rear, center Wall Panels as shown. **Do not overtighten.**
- Sujete un Soporte mural (con una Extensión corta) a cada Panel mural trasero lateral como se muestra. **No apriete demasiado.** Sujete un Soporte mural (con una Extensión larga) a cada Panel mural trasero central como se muestra. **No apriete demasiado.**
- Attachez un Support mural (avec un Rallonge court) à chaque Panneau mural arrière latéral comme illustré. **Ne pas trop serrer.** Attachez un Support mural (avec un Rallonge long) à chaque Panneau mural arrière central comme illustré. **Ne pas trop serrer.**



Short / Corto / Court

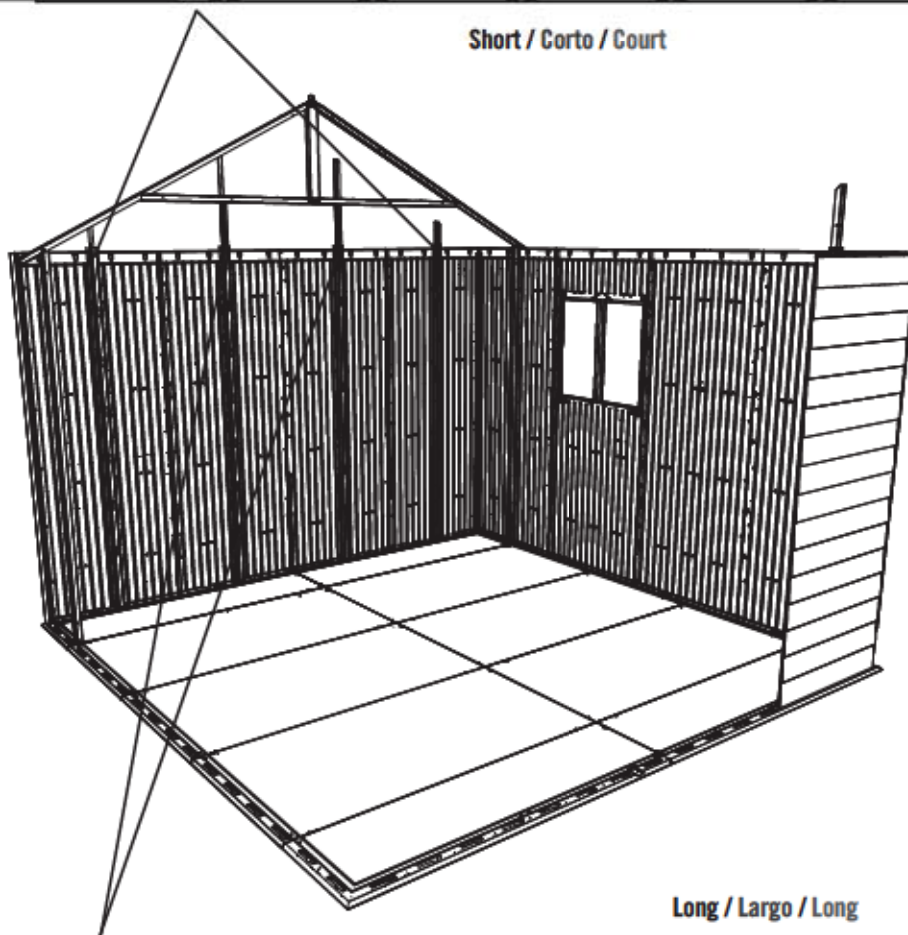

Long / Largo / Long



# 10

## SHELF INSTALLATION / INSTALACIÓN DE LOS ESTANTES / INSTALLATION DES ÉTAGÈRES



### HARDWARE REQUIRED / ACCESORIOS REQUERIDOS / ACCESSOIRES REQUIS

Hardware Bags / Bolsas de accesorios / Sacs d'accessoires

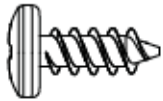

ADZ (x70)



AIY (x10)

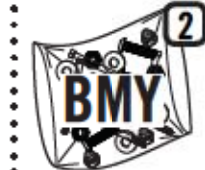

ADX (x8)



AEE (x8)



### PARTS REQUIRED / PIEZAS REQUERIDAS / PIÈCES REQUISES

Metal Parts / Piezas de metal / Pièces en métal



AIZ (x4)

Plastic Parts / Piezas de plástico / Pièces en plastique



AFS (x5)



AFT (x2)



### TOOLS REQUIRED / HERRAMIENTAS REQUERIDAS / OUTILS REQUIS



## ► SECTION 10 (CONTINUED) / SECCIÓN 10 (SIGUE) / SECTION 10 (SUITE)

TOOLS AND HARDWARE REQUIRED / HERRAMIENTAS Y ACCESORIOS REQUERIDOS / OUTILS ET ACCESSOIRES REQUIS



AIY (x10)

### 10.1

10" x 30" (25,4 cm x 76,2 cm) (AFS)

- Decide where you would like to place your 10" (25,4 cm) Shelves. Insert two **Shelf Brackets (AIY)** into opposite slots in the Shelf Support Channels as shown.
- Decida donde le gustaría colocar los Estantes de 25,4 cm (10"). Inserte dos **Escuadras (AIY)** en las ranuras opuestas en los Canales de soporte como se muestra.
- Décidez où vous voudriez placer vos Étagères de 25,4 cm (10"). Insérez deux **Équerres (AIY)** dans les fentes opposées dans les Canaux de support comme illustré.

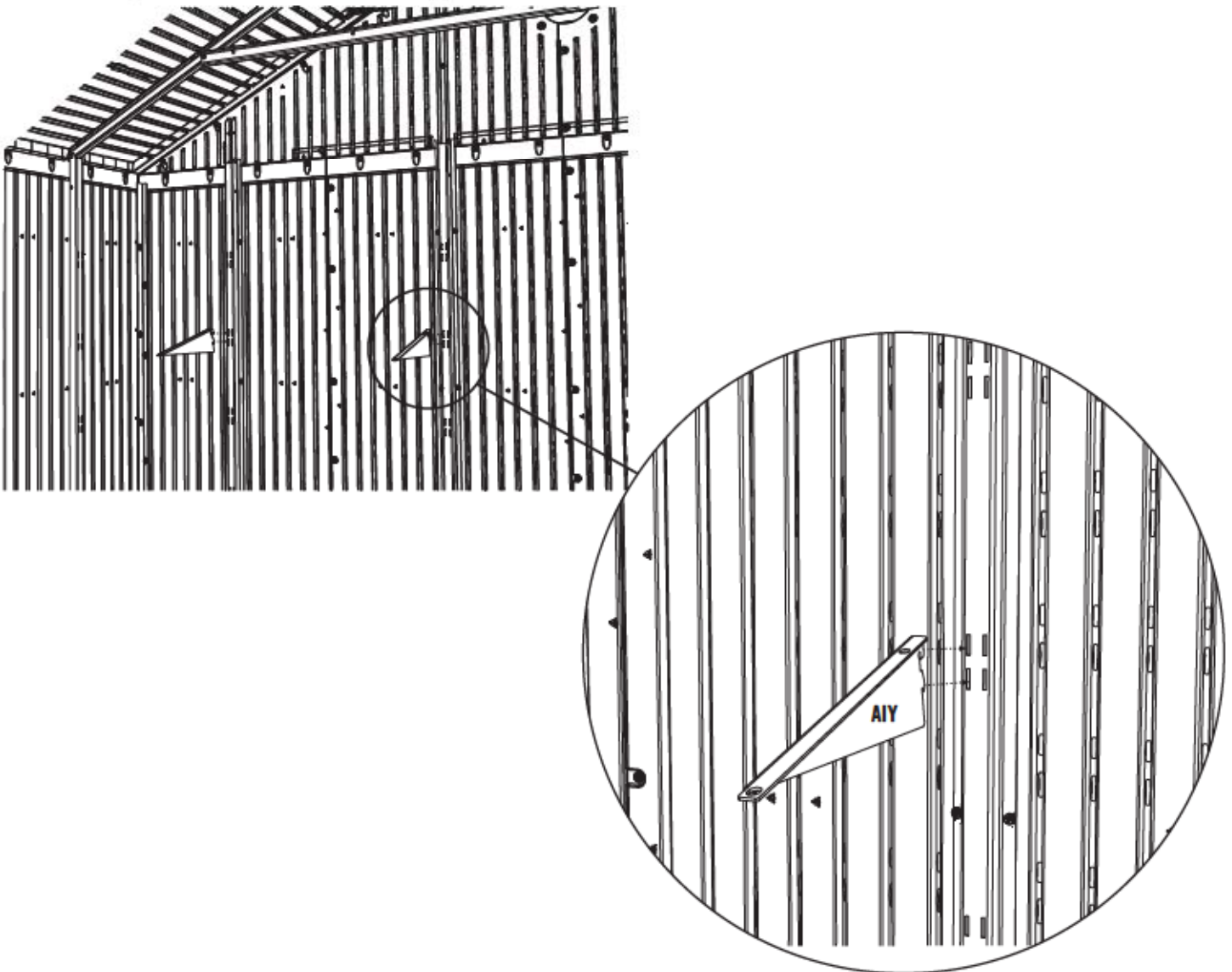



**THIS PAGE INTENTIONALLY LEFT BLANK  
ESTA PÁGINA SE HA DEJADO EN BLANCO INTENCIONADAMENTE.  
CETTE PAGE A ÉTÉ INTENTIONNELLEMENT LAISSÉE EN BLANC.**

**Remove This Section / Retire Esta Sección / Enlevez Cette Section**



# PARTS IDENTIFIER / IDENTIFICADOR DE PIEZAS / IDENTIFICATEUR DE PIÈCES

CONTENTS OF BOX 1 / CONTENIDO DE LA CAJA 1 / CONTENU DE LA BOÎTE 1

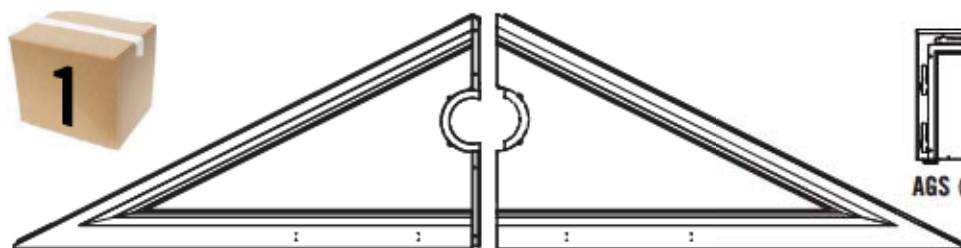

AGI (x2)

AGH (x2)



AGS (x2)



AFS (x5)

Remove This Section / Retire Esta Sección / Enlevez Cette Section

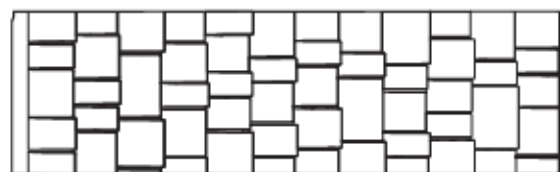

AGU (x2)



AGE (x2)



AGT (x2)

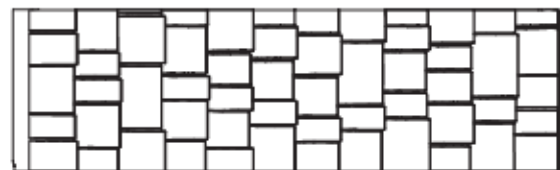

AGV (x2)

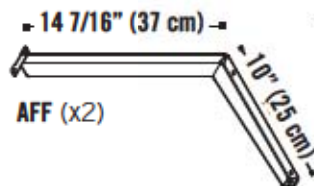

AFF (x2)

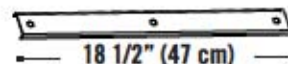

AFB (x6)



AFT (x2)

CONTENTS OF SMALL PARTS BOX / CONTENIDO DE LA CAJA DE PIEZAS PEQUEÑAS / CONTENU DE LA BOÎTE DE PETITES PIÈCES

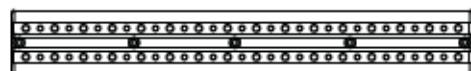

AFU (x2)



AIZ (x4)

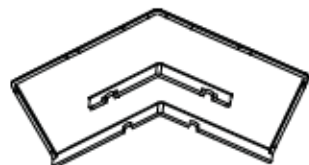

AHA (x2)

HARDWARE BAGS / BOLSAS DE ACCESORIOS DE FIJACIÓN / SACS DE ACCESSOIRES





# PARTS IDENTIFIER / IDENTIFICADOR DE PIEZAS / IDENTIFICATEUR DE PIÈCES

CONTENTS METAL KIT 1 / CONTENIDO DEL KIT 1 DE PIEZAS DE METAL / CONTENU DU KIT 1 DE PIÈCES EN MÉTAL

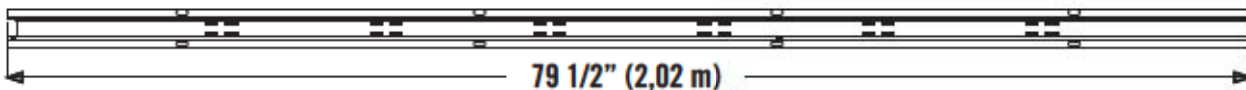

AFQ (x8)

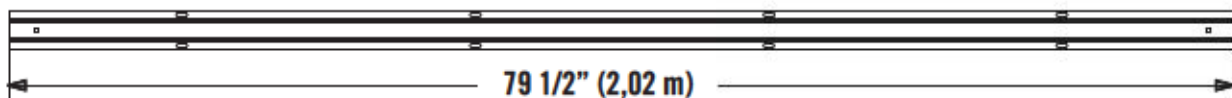

AFG (x1)

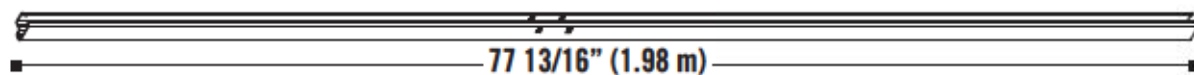

AFC (x2)

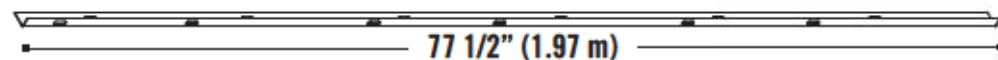

AFR (x4)

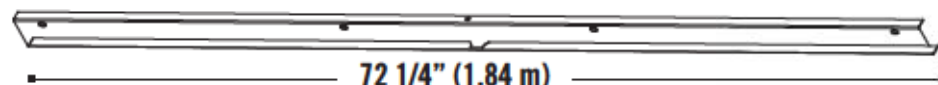

AFD (x1)

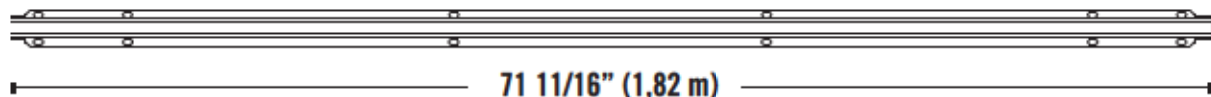

AFH (x2)

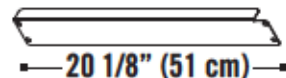

AFP (x2)

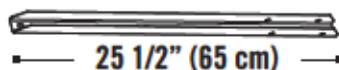

AFJ (x2)

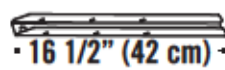

AFN (x4)

CONTENTS METAL KIT 2 / CONTENIDO DEL KIT 2 DE PIEZAS DE METAL / CONTENU DU KIT 2 DE PIÈCES EN MÉTAL



AFI (x1)



AFK (x1)



Remove This Section / Retire Esta Sección / Enlevez Cette Section



# PARTS IDENTIFIER / IDENTIFICADOR DE PIEZAS / IDENTIFICATEUR DE PIÈCES

CONTENTS OF BOX 2 / CONTENIDO DE LA CAJA 2 / CONTENU DE LA BOÎTE 2



Remove This Section / Retire Esta Sección / Enlevez Cette Section

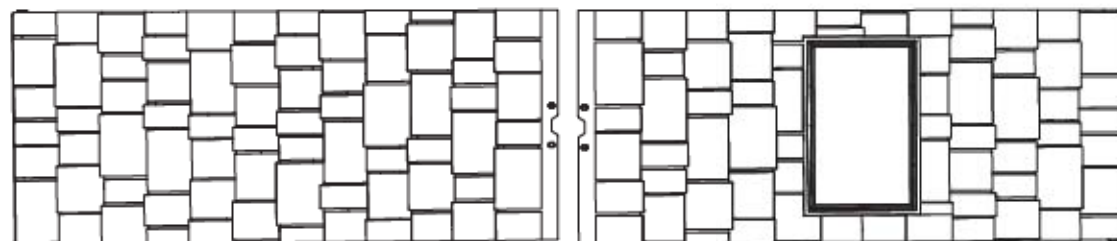

AGQ (x3)

AHB (x1)

28 7/8" (73 cm)



AHD (x3)

AHH (x1)

AFL (x12)



AGJ (x4)

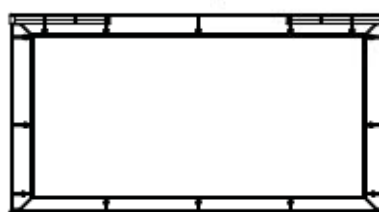

AHG (x2)

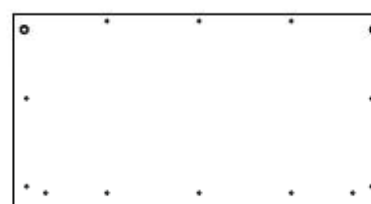

AHF (x2)



AFY (x2)

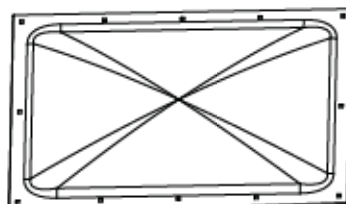

AGB (x1)

CONTENTS OF METAL KIT 3 / CONTENIDO DEL KIT DE PIEZAS DE METAL 3 / CONTENU DU KIT PIÈCES EN MÉTAL 3

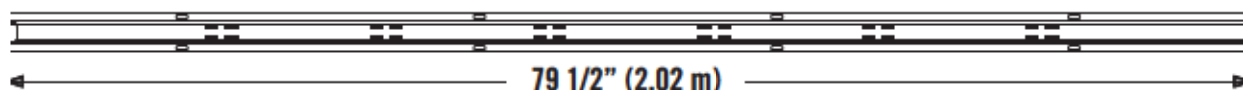

AFQ (x4)





# PARTS IDENTIFIER / IDENTIFICADOR DE PIEZAS / IDENTIFICATEUR DE PIÈCES

CONTENTS OF METAL KIT 4 / CONTENIDO DEL KIT DE PIEZAS DE METAL 4 / CONTENU DU KIT PIÈCES EN MÉTAL 4

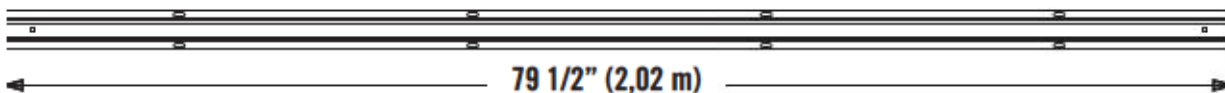

AFG (x2)

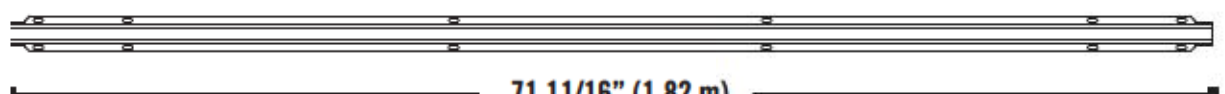

AFH (x4)

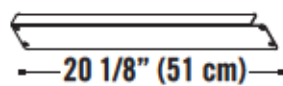

AFP (x4)



HARDWARE BAGS / BOLSAS DE ACCESORIOS DE FIJACIÓN / SACS D'ACCESSOIRES



CONTENTS OF BOX 3 / CONTENIDO DE LA CAJA 3 / CONTENU DE LA BOÎTE 3

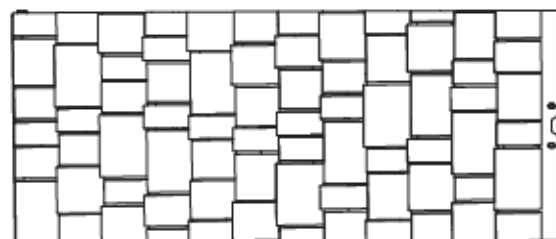

AGQ (x1)

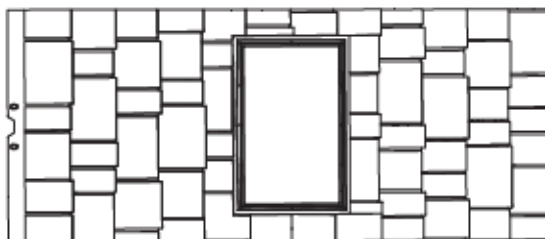

AHB (x1)



AHD (x1)

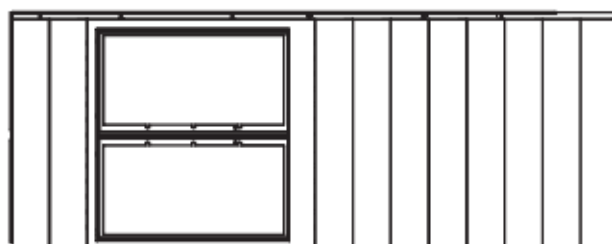

AHH (x1)

Remove This Section / Retire Esta Sección / Enlevez Cette Section



# PARTS IDENTIFIER / IDENTIFICADOR DE PIEZAS / IDENTIFICATEUR DE PIÈCES

CONTENTS OF BOX 3 / CONTENIDO DE LA CAJA 3 / CONTENU DE LA BOÎTE 3



AGJ (x2)

28 7/8" (73 cm)



AFY (x1)

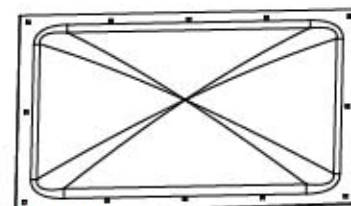

AGB (x1)

AFL (x6)

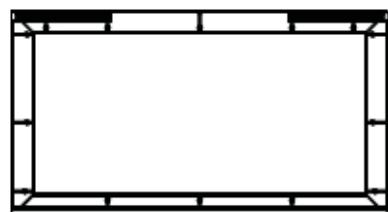

AHG (x2)

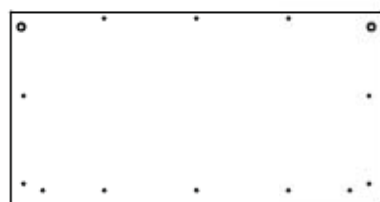

AHF (x2)

CONTENTS OF METAL KIT 5 / CONTENIDO DEL KIT DE PIEZAS DE METAL 5 / CONTENU DU KIT PIÈCES EN MÉTAL 5

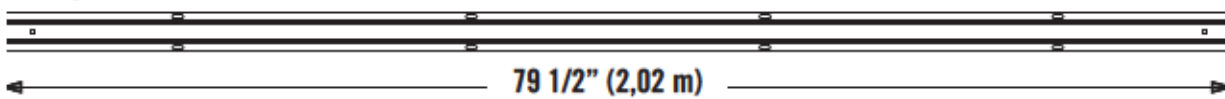

AFG (x1)

79 1/2" (2,02 m)



AFH (x2)

71 11/16" (1,82 m)



CONTENTS OF METAL KIT 6 / CONTENIDO DEL KIT DE PIEZAS DE METAL 6 / CONTENU DU KIT PIÈCES EN MÉTAL 6

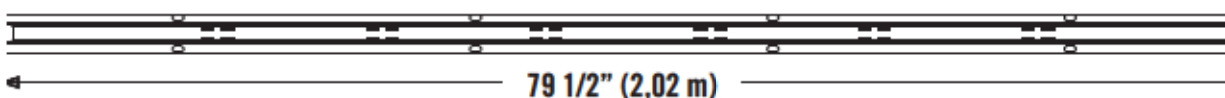

AFQ (x2)

79 1/2" (2,02 m)

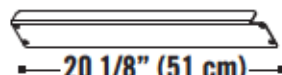

20 1/8" (51 cm)

AFP (x2)

Remove This Section / Retire Esta Sección / Enlevez Cette Section



# PARTS IDENTIFIER / IDENTIFICADOR DE PIEZAS / IDENTIFICATEUR DE PIÈCES

HARDWARE BAGS / BOLSAS DE ACCESORIOS DE FIJACIÓN / SACS D'ACCESSOIRES



CONTENTS OF BOX 4 / CONTENIDO DE LA CAJA 4 / CONTENU DE LA BOÎTE 4

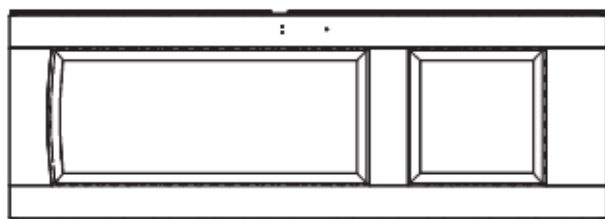

AGO (x1)

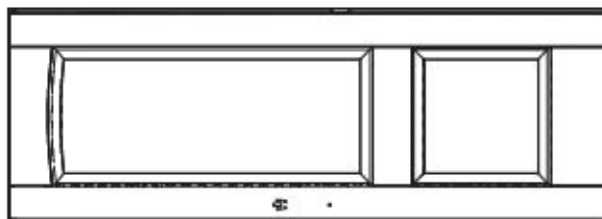

AGZ (x1)



AHD (x8)

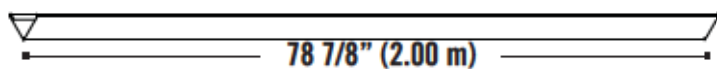

AQX (x4)

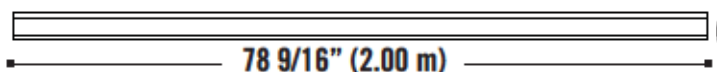

AGD (x2)

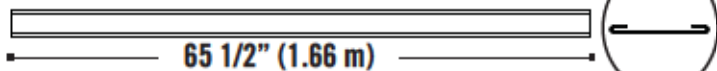

AGC (x1)

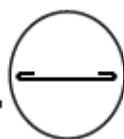

Remove This Section / Retire Esta Sección / Enlevez Cette Section



**THIS PAGE INTENTIONALLY LEFT BLANK  
ESTA PÁGINA SE HA DEJADO EN BLANCO INTENCIONADAMENTE.  
CETTE PAGE A ÉTÉ INTENTIONNELLEMENT LAISSÉE EN BLANC.**

**Remove This Section / Retire Esta Sección / Enlevez Cette Section**

## ► SECTION 10 (CONTINUED) / SECCIÓN 10 (SIGUE) / SECTION 10 (SUITE)

TOOLS AND HARDWARE REQUIRED / HERRAMIENTAS Y ACCESORIOS REQUERIDOS / OUTILS ET ACCESSOIRES REQUIS

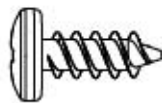

ADZ (x20)

### 10.2

- Attach a **Shelf (AFS)** to the Shelf Brackets using the hardware shown.
- Sujete un **Estante (AFS)** a las Escuadras usando los accesorios ilustrados.
- Attachez une **Étagère (AFS)** aux Équerres à l'aide des accessoires illustrés.

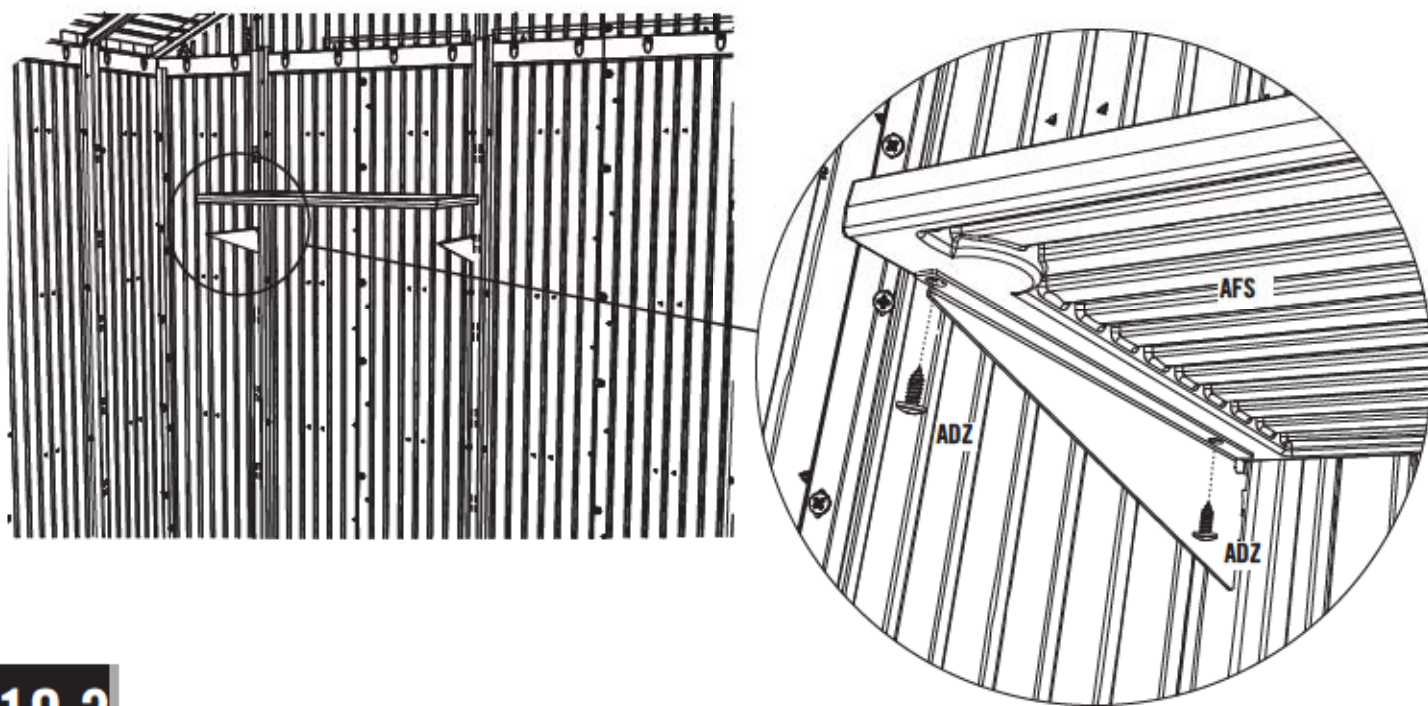

### 10.3

- Repeat steps 10.1–10.2 for the remaining 10" x 30" (25,4 cm x 76,2 cm) Shelves (AFS).
- Repita los pasos 10.1–10.2 para los Estantes de 25,4 cm x 76,2 cm (10" x 30") (AFS) restantes.
- Répétez les étapes 10.1 – 10.2 pour les Étagères de 25,4 cm x 76,2 cm (10" x 30") (AFS) restantes.



↓ 30 lb. (14 kg)

## ► SECTION 10 (CONTINUED) / SECCIÓN 10 (SIGUE) / SECTION 10 (SUITE)

TOOLS AND HARDWARE REQUIRED / HERRAMIENTAS Y ACCESORIOS REQUERIDOS / OUTILS ET ACCESSOIRES REQUIS



AIZ (x4)

### 10.4

14" x 30" (36,6 cm x 76,2 cm) (AFT)

- Decide where you would like to place your 14" (36,6 cm) Shelves. Insert two **Shelf Brackets (AIZ)** into opposite slots in the Shelf Support Channels as shown.
- Decida donde le gustaría colocar los Estantes de 36,6 cm (14"). Inserte dos **Escuadras (AIZ)** en las ranuras opuestas en los Canales de soporte como se muestra.
- Décidez où vous voudriez placer vos Étagères de 36,6 cm (14"). Insérez deux **Équerres (AIZ)** dans les fentes opposées dans les Canaux de support comme illustré.

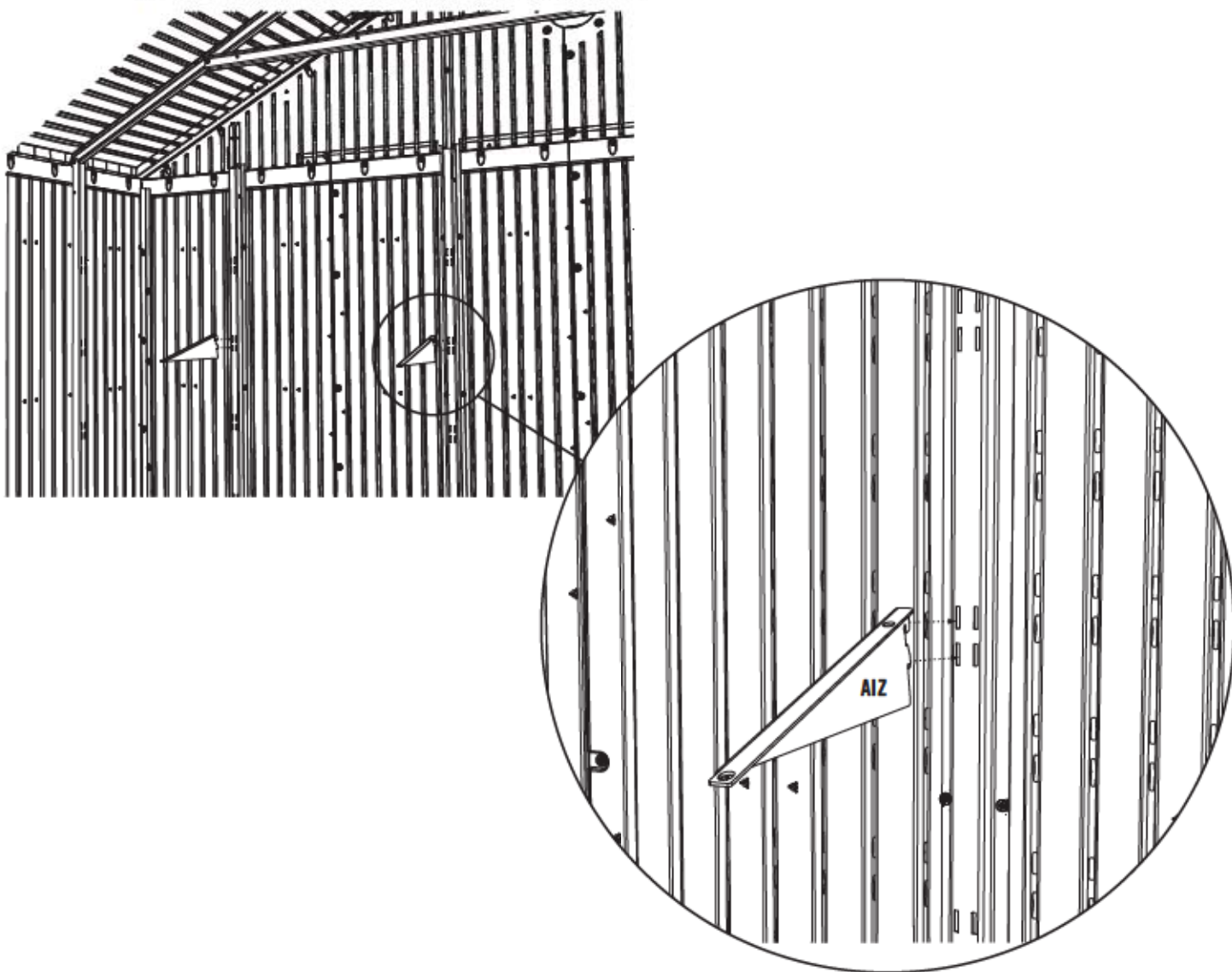

## ► SECTION 10 (CONTINUED) / SECCIÓN 10 (SIGUE) / SECTION 10 (SUITE)

TOOLS AND HARDWARE REQUIRED / HERRAMIENTAS Y ACCESORIOS REQUERIDOS / OUTILS ET ACCESSOIRES REQUIS



ADX (x8)



AEE (x8)

### 10.5

- Attach a **Shelf (AFT)** to the Shelf Brackets using the hardware shown.
- Sujete un **Estante (AFT)** a las Escuadras usando los accesorios ilustrados.
- Attachez une **Étagère (AFT)** aux Équerres à l'aide des accessoires illustrés.

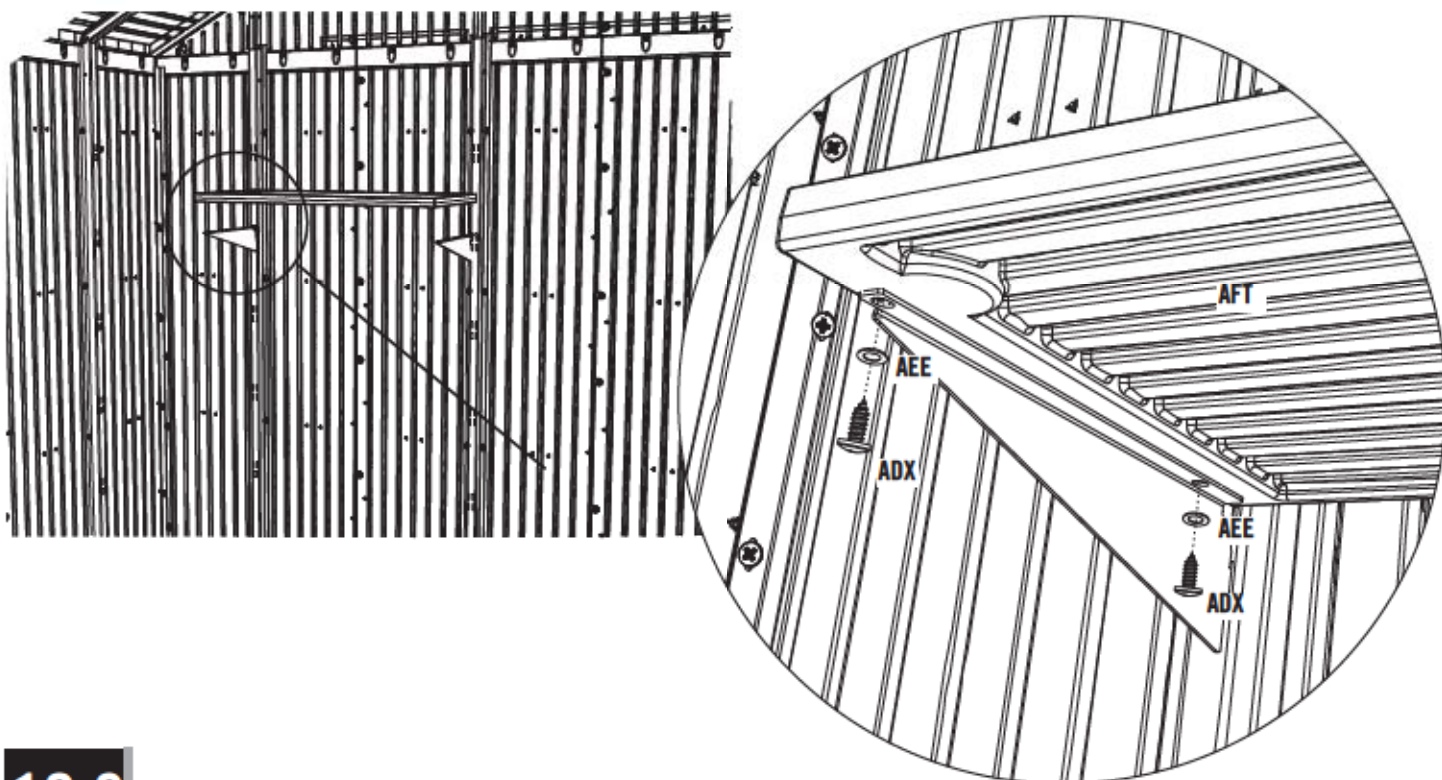

### 10.6

- Repeat steps 10.4–10.5 for the remaining 14" x 30" (36,6 cm x 76,2 cm ) Shelf (AFT).
- Repita los pasos 10.4–10.5 para el Estante de 36,6 cm x 76,2 cm (14" x 30") (AFT) restante.
- Répétez les étapes 10.4 – 10.5 pour l'Étagère de 36,6 cm x 76,2 cm (14" x 30") (AFT) restante.



↓ 30 lb. (14 kg)

# 11

## DOOR & ENTRY GABLE INSTALLATION / INSTALACIÓN DE LAS PUERTAS Y LA FACHADA DE ENTRADA / INSTALLATION DES PORTES ET LE TOIT À PIGNON D'ENTRÉE



### HARDWARE REQUIRED / ACCESORIOS REQUERIDOS / ACCESSOIRES REQUIS

Hardware Bags / Bolsas de accesorios / Sacs d'accessoires



ACH (x4)



ADZ (x24)



ADX (x2)

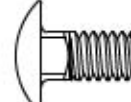

ACA (x4)



ADJ (x8)



AEB (x4)



AHN (x2)



AHL (x1)



### PARTS REQUIRED / PIEZAS REQUERIDAS / PIÈCES REQUISES

Metal Parts / Piezas de metal / Pièces en métal



AFI (x1)

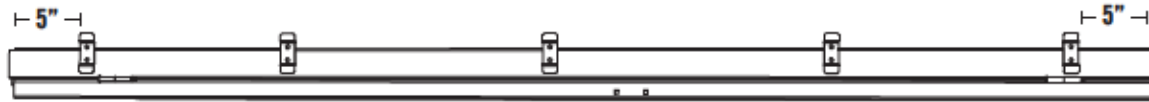

AFK (x1)

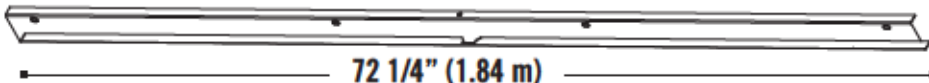

AFD (x1)



Plastic Parts / Piezas de plástico / Pièces en plastique

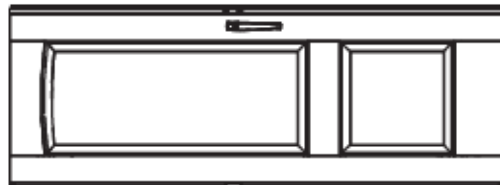

(x1)

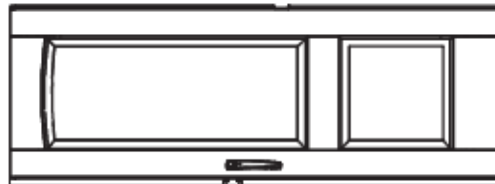

(x1)



### TOOLS REQUIRED / HERRAMIENTAS REQUERIDAS / OUTILS REQUIS



7/16" (11 mm)

## ► SECTION 11 (CONTINUED) / SECCIÓN 11 (SIGUE) / SECTION 11 (SUITE)

TOOLS AND HARDWARE REQUIRED / HERRAMIENTAS Y ACCESORIOS REQUERIDOS / OUTILS ET ACCESSOIRES REQUIS

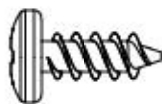

ADZ (x10)

### 11.1



- Set a Gable Assembly down onto the two front Wall Panels as shown.
- Coloque un Conjunto de la fachada encima de los Paneles murales delanteros como se muestra
- Mettez un Ensemble du toit à pignon sur les deux Panneaux muraux avants comme illustré.

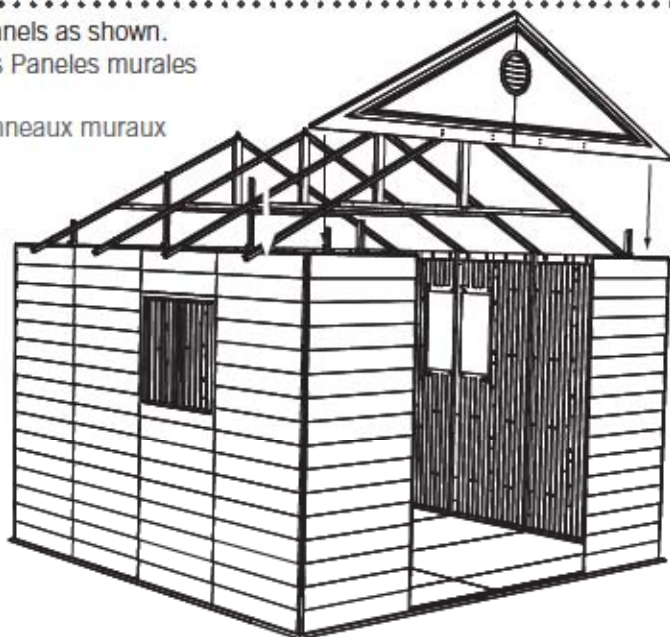

### 11.2

- Secure the Gable to the shed at the locations shown using ten (10) Screws (ADZ).
- Sujete la Fachada al cobertizo a las ubicaciones ilustradas usando diez (10) Tornillos (ADZ).
- Attachez bien le Toit à pignon à l'abri aux emplacements illustrés à l'aide de dix (10) Vis (ADZ).

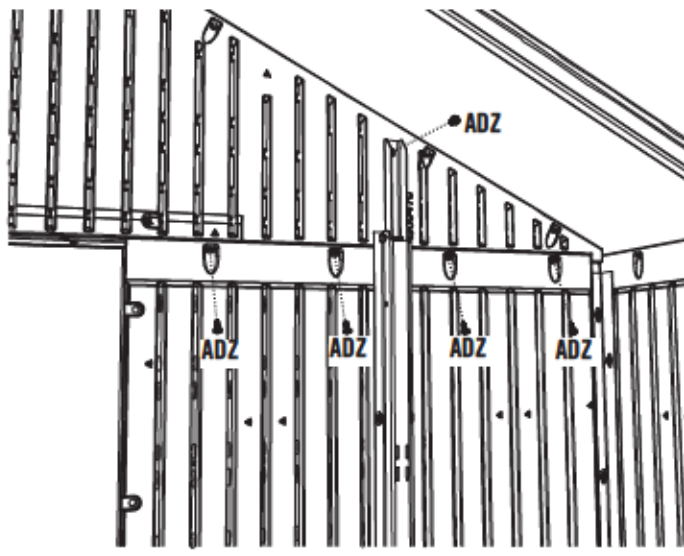
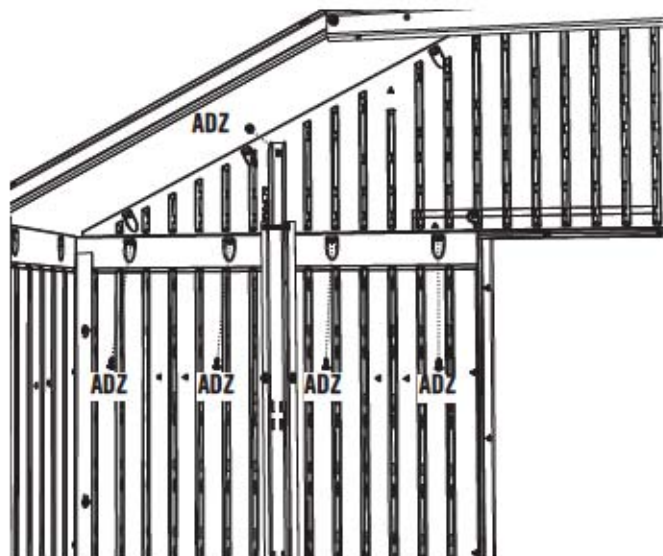

## ► SECTION 11 (CONTINUED) / SECCIÓN 11 (SIGUE) / SECTION 11 (SUITE)

TOOLS AND HARDWARE REQUIRED / HERRAMIENTAS Y ACCESORIOS REQUERIDOS / OUTILS ET ACCESSOIRES REQUIS

  
7/16" (x2)  
11,1 mm (x2)



AHN (x1)

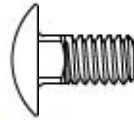

ACA (x2)



ADJ (x2)

### 11.3

- Attach the following hardware to the **Right Hinge (AFK)**. Only hand tighten the top Nut (ADJ).
- Sujete los accesorios siguientes a la **Bisagra derecha (AFK)**. Apriete la Tuerca (ADJ) superior sólo a mano.
- Attachez les accessoires suivants à la **Charnière droite (AFK)**. Serrez l'Écrou (ADJ) supérieur à la main seulement.

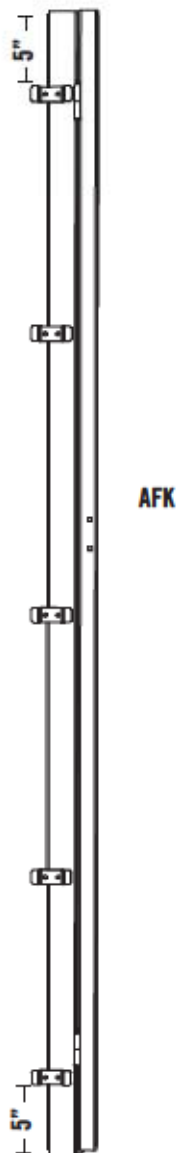

AFK

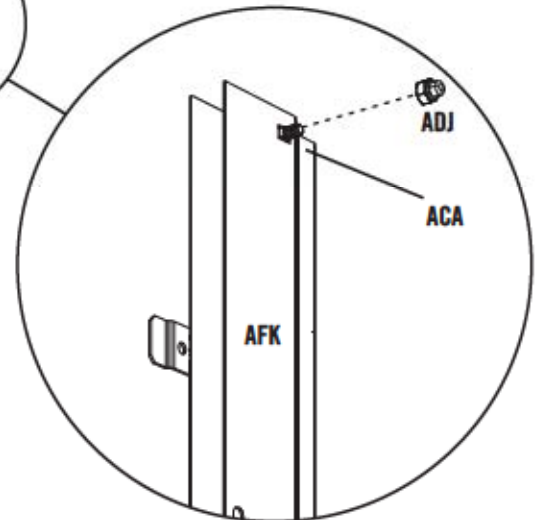

ADJ

ACA

AFK

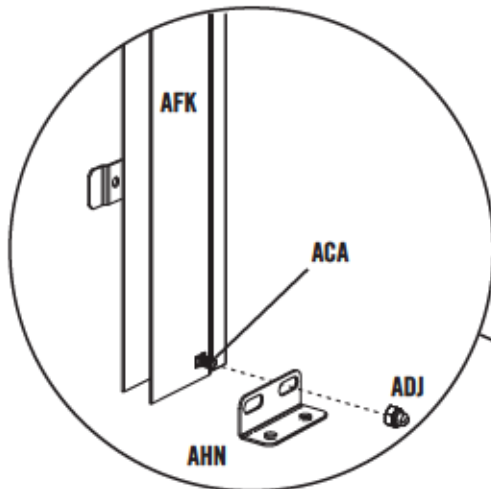

AFK

ACA

ADJ

AHN

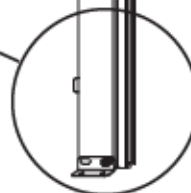

AFK

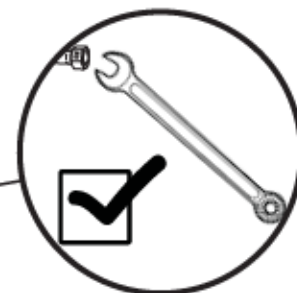

## ► SECTION 11 (CONTINUED) / SECCIÓN 11 (SIGUE) / SECTION 11 (SUITE)

TOOLS AND HARDWARE REQUIRED / HERRAMIENTAS Y ACCESORIOS REQUERIDOS / OUTILS ET ACCESSOIRES REQUIS

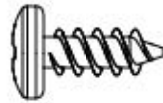

ADZ (x5)

### 11.4

- Slide the edge of the Right Hinge over right, front Wall Panel, align the holes, and secure with five (5) **Screws (ADZ)**.
- Deslice el borde de la Bisagra derecha sobre el Panel mural derecho delantero, alinee los agujeros, y sujételo usando cinco (5) **Tornillos (ADZ)**.
- Glissez le bord de la Charnière droite sur le Panneau mural droit avant, alignez les trous, et attachez-le à l'aide de cinq (5) **Vis (ADZ)**.

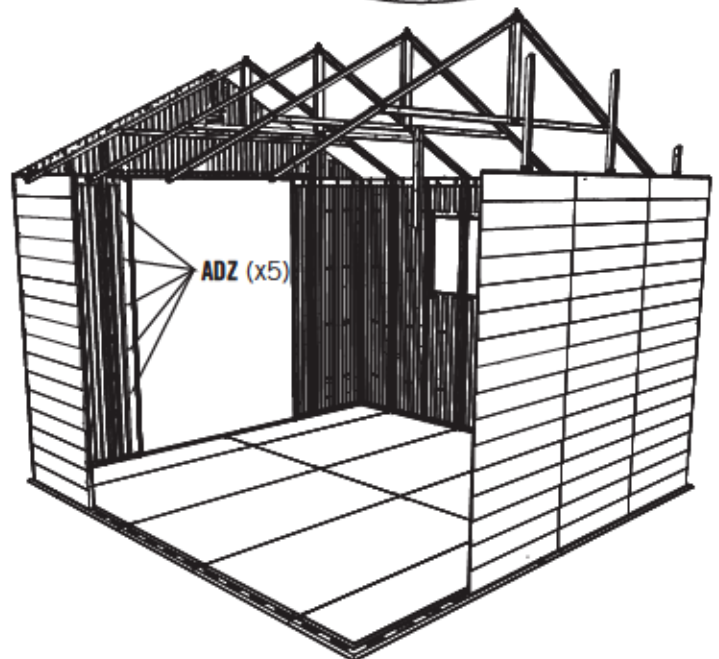
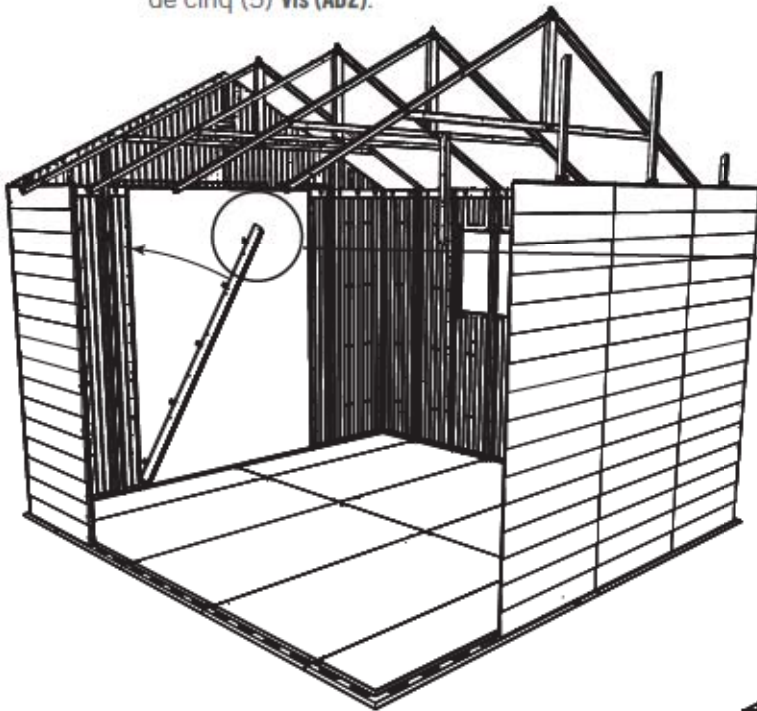

## ► SECTION 11 (CONTINUED) / SECCIÓN 11 (SIGUE) / SECTION 11 (SUITE)

TOOLS AND HARDWARE REQUIRED / HERRAMIENTAS Y ACCESORIOS REQUERIDOS / OUTILS ET ACCESSOIRES REQUIS

  
7/16" (x2)  
11,1 mm (x2)



AHN (x1)

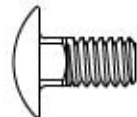

ACA (x2)



ADJ (x2)

### 11.5

- Attach the following hardware to the **Left Hinge (AFI)**. Only hand tighten the top **Nut (ADJ)**.
- Sujete los accesorios siguientes a la **Bisagra izquierda (AFI)**. Apriete la **Tuerca (ADJ)** superior sólo a mano.
- Attachez les accessoires suivants à la **Charnière gauche (AFI)**. Serrez l'**Écrou (ADJ)** supérieur à la main seulement.

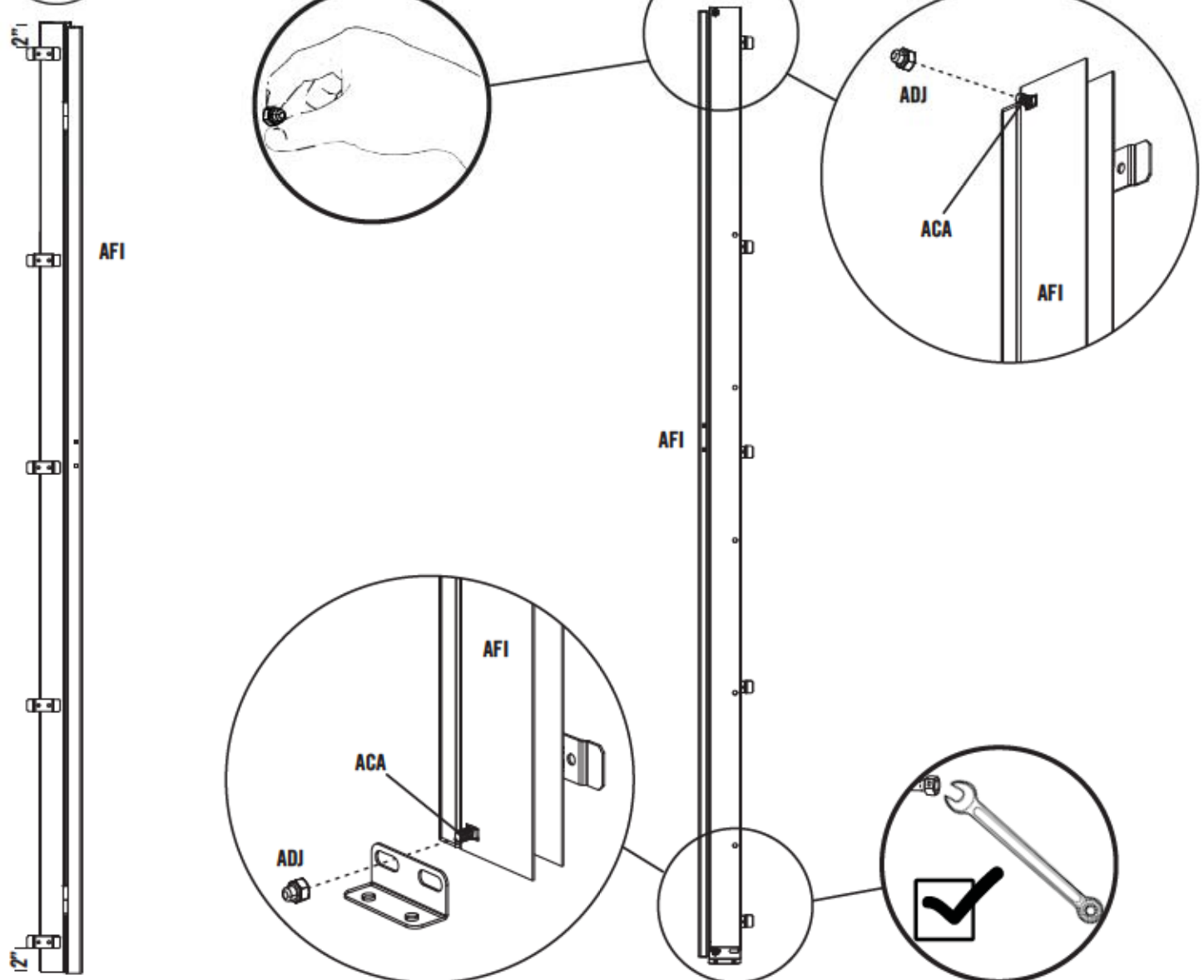

## ► SECTION 11 (CONTINUED) / SECCIÓN 11 (SIGUE) / SECTION 11 (SUITE)

TOOLS AND HARDWARE REQUIRED / HERRAMIENTAS Y ACCESORIOS REQUERIDOS / OUTILS ET ACCESSOIRES REQUIS



ADZ (x5)

### 11.6

- Slide the edge of the Left Hinge over right, front Wall Panel, align the holes, and secure with five (5) **Screws (ADZ)**.
- Deslice el borde de la Bisagra izquierda sobre el Panel mural derecho delantero, alinee los agujeros, y sujételo usando cinco (5) **Tornillos (ADZ)**.
- Glissez le bord de la Charnière gauche sur le Panneau mural droit avant, alignez les trous, et attachez-le à l'aide de cinq (5) **Vis (ADZ)**.

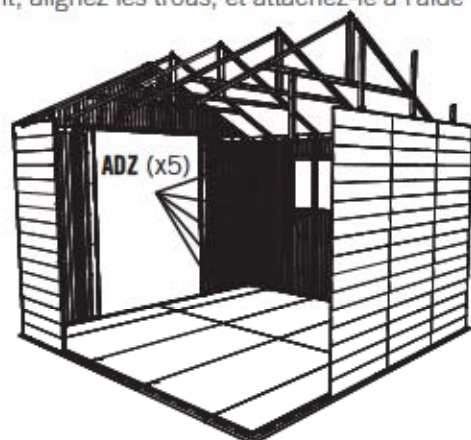
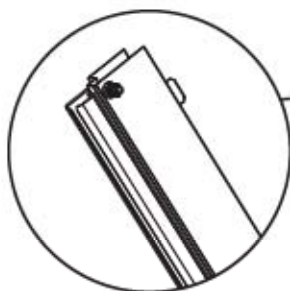

### 11.7

- Remove the Nuts you tightened by hand in the previous steps from the top of the Hinges. **Remove only the two Nuts.**
- Retire las Tuercas que apretó a mano en los pasos anteriores de los extremos superiores de las Bisagras. **Retire sólo las dos Tuercas.**
- Soulevez les Écrous que vous avez serrés à la main dans les étapes précédentes des extrémités supérieures des Charnières. **Soulevez seulement les deux Écrous.**

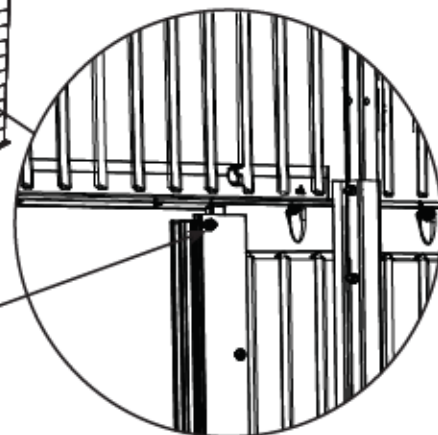
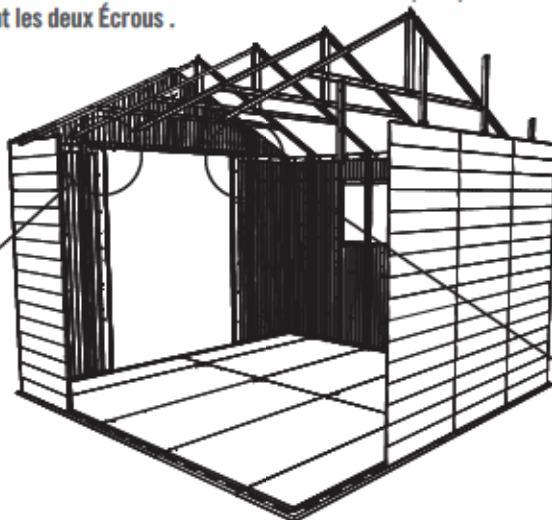
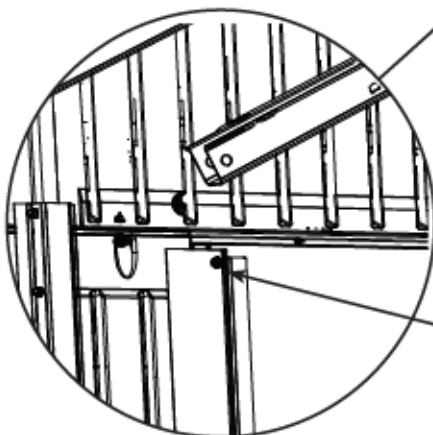

Nuts / Tuercas / Écrous

## ► SECTION 11 (CONTINUED) / SECCIÓN 11 (SIGUE) / SECTION 11 (SUITE)

TOOLS AND HARDWARE REQUIRED / HERRAMIENTAS Y ACCESORIOS REQUERIDOS / OUTILS ET ACCESSOIRES REQUIS



7/16" (x2)  
11,1 mm (x2)

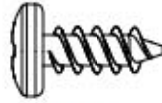

ADZ (x4)

### 11.8

- Place the **Door Header (AFD)** over the Bolts and, with a wrench, retighten the Nuts you removed in the previous step.
- Sujete el **Dintel (AFD)** sobre los Pernos y, avec una llave, reapriete las Tuercas que retiró en el paso anterior.
- Placez le **Lintheau (AFD)** sur les Boulons et, à l'aide d'un clé, resserrez les Écrous que vous avez enlevé dans l'étape précédente.

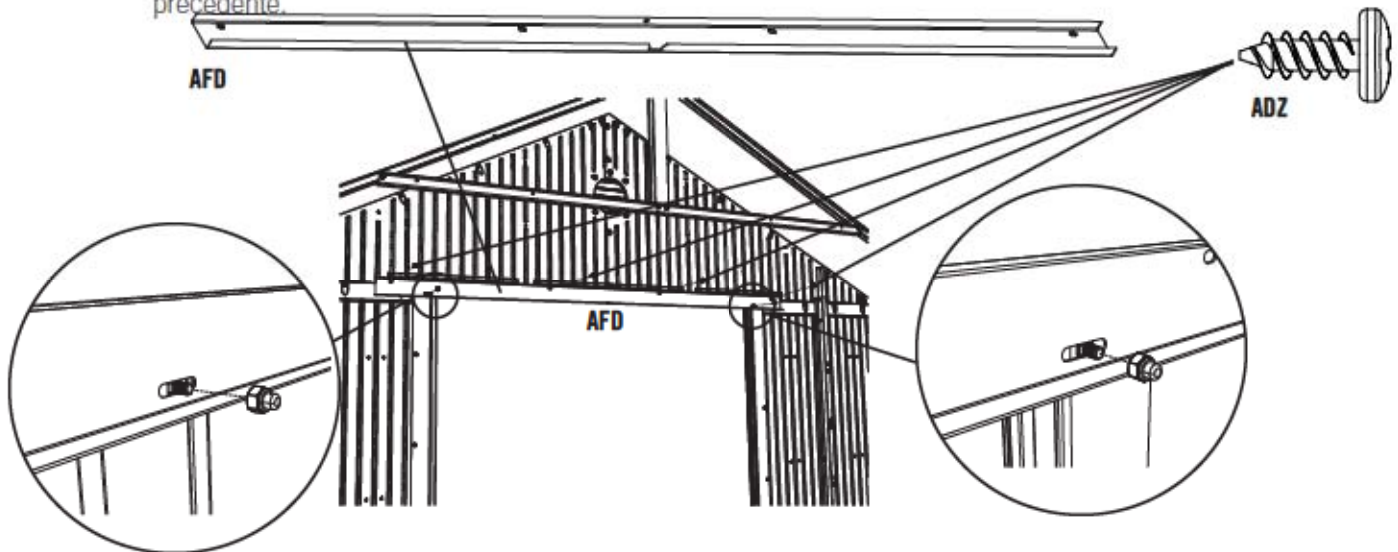

### 11.9

- Slide the Left Door down into the Left Hinge as shown.
- Deslice la Puerta izquierda dentro de la Bisagra izquierda como se muestra.
- Glissez la Porte gauche dans la Charnière gauche comme illustré.

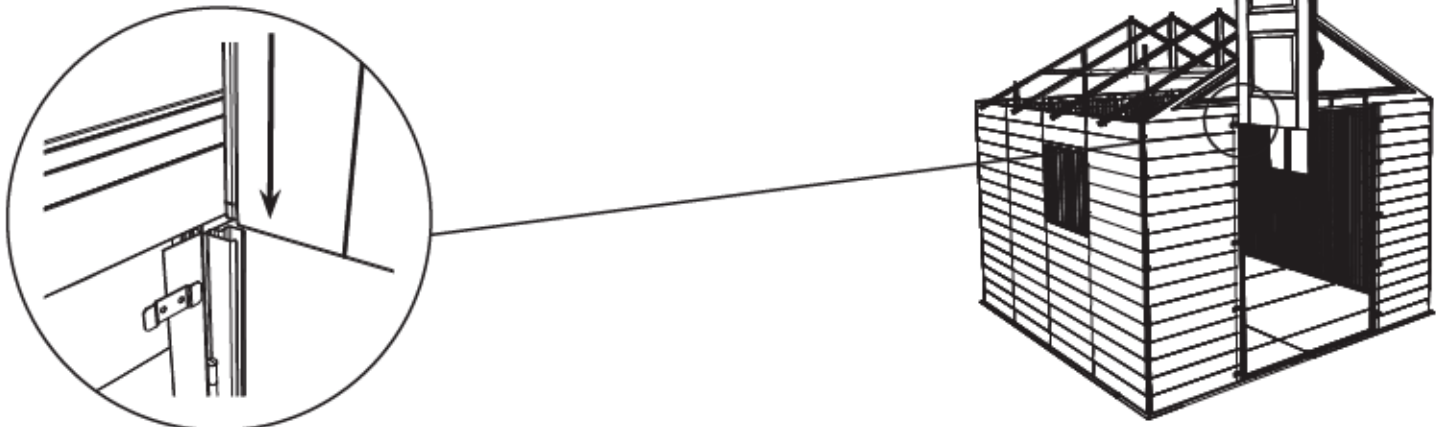

## ► SECTION 11 (CONTINUED) / SECCIÓN 11 (SIGUE) / SECTION 11 (SUITE)

TOOLS AND HARDWARE REQUIRED / HERRAMIENTAS Y ACCESORIOS REQUERIDOS / OUTILS ET ACCESSOIRES REQUIS



7/16" (x2)  
11,1 mm (x2)

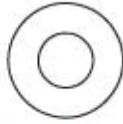

AEB (x4)



ADJ (x4)



ACH (x4)

### 11.10

- Align the holes in the Hinge with those in the Left Door. Secure the Door to the Hinge using the hardware provided.
- Alinee los agujeros en la Bisagra con ellos en la Puerta izquierda. Sujete la Puerta a la Bisagra usando los accesorios provistos.
- Allignez les trous dans la Charnière avec ceux de la Porte gauche. Attachez la Porte à la Charnière à l'aide des accessoires fournis.



### 11.11

- Repeat steps 11.9–11.10 for the Right Door.
- Repita los pasos 11.9–11.10 para la Puerta derecha.
- Répétez les étapes 11.9 – 11.10 pour la Porte droite.

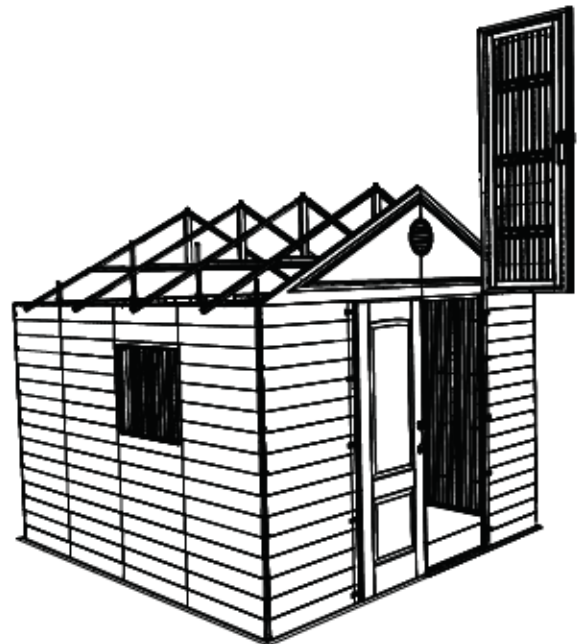

## ► SECTION 11 (CONTINUED) / SECCIÓN 11 (SIGUE) / SECTION 11 (SUITE)

TOOLS AND HARDWARE REQUIRED / HERRAMIENTAS Y ACCESORIOS REQUERIDOS / OUTILS ET ACCESSOIRES REQUIS



AHL (x1)



ADX (x2)

### 11.12

- Attach the **Strike Plate (AHL)** to the Floor using two (2) **Screws (ADX)**.
- Sujete la **Placa de refuerzo (AHL)** al Piso usando dos (2) **Tornillos (ADX)**.
- Attachez la **Strike Plate (AHL)** au Plancher à l'aide de deux (2) **Vis (ADX)**.

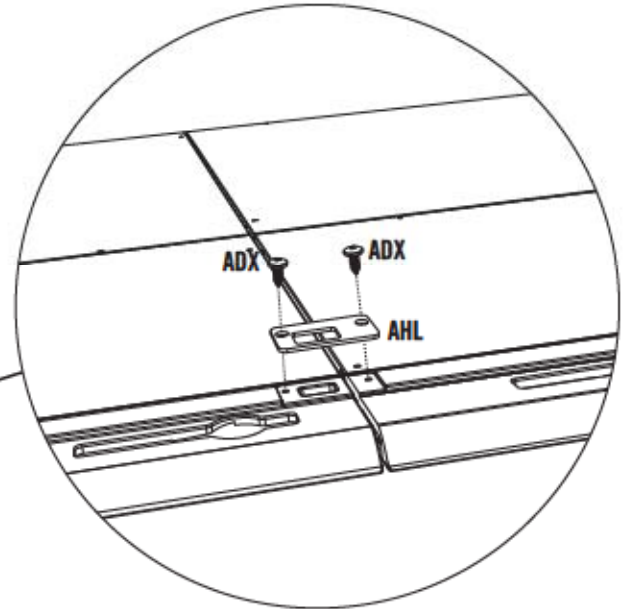



### HARDWARE REQUIRED / ACCESORIOS REQUERIDOS / ACCESSOIRES REQUIS

Hardware Bags / Bolsas de accesorios / Sacs d'accessoires



AHR (x2)



ADX (56)



AHQ (x4)



AYR (4)

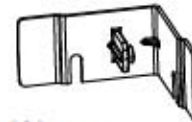

AGA (x24)



### PARTS REQUIRED / PIEZAS REQUERIDAS / PIÈCES REQUISES

Plastic Parts / Piezas de plástico / Pièces en plastique

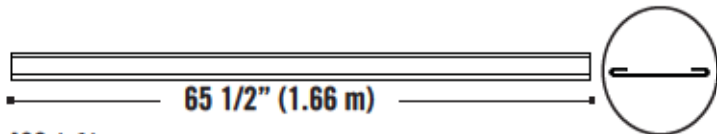

AGC (x1)

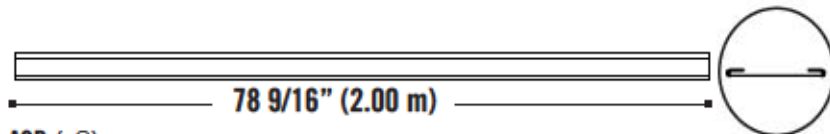

AGD (x2)

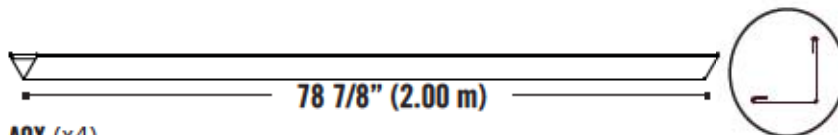

AQX (x4)



### TOOLS REQUIRED / HERRAMIENTAS REQUERIDAS / OUTILS REQUIS



## ► SECTION 12 (CONTINUED) / SECCIÓN 12 (SIGUE) / SECTION 12 (SUITE)

TOOLS AND HARDWARE REQUIRED / HERRAMIENTAS Y ACCESORIOS REQUERIDOS / OUTILS ET ACCESSOIRES REQUIS



ADX (8)

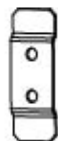

AHQ (x4)



AHR (x2)

### 12.1

- Slide the two (2) pieces of **Vertical Trim (AGD)** down over the trim brackets.
- Deslice las dos (2) piezas de **Molduras verticales (AGD)** sobre los soportes de moldura.
- Glissez les deux (2) pièces de **Moulures verticales (AGD)** sur les supports à moulure.

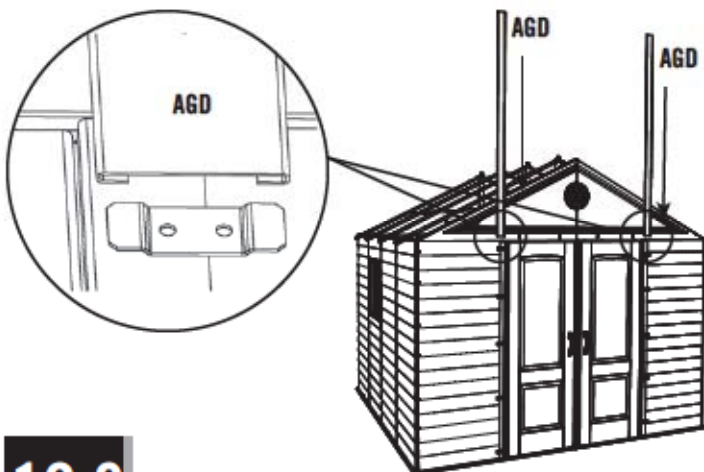

### 12.2

- Attach the four (4) **Horizontal Trim Brackets (AHQ)** above the Doors as shown.
- Sujete los cuatro (4) **Supports para la moldura horizontal (AHQ)** encima de las puertas como se muestra.
- Attachez les quatre (4) **Supports à moulure horizontale (AHQ)** sur les portes comme illustré.

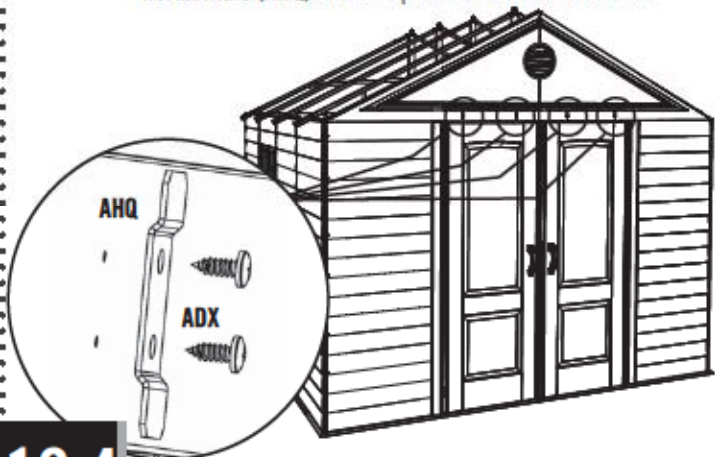

### 12.3

- Insert one (1) **Trim Clip (AHR)** into the top of each piece of Vertical Trim.
- Inserte un (1) **Clip para la moldura (AHR)** dentro del extremo superior de cada pieza de moldura vertical.
- Insérez un (1) **Clip à moulure (AHR)** dedans l'extrémité supérieure de chaque pièce de moulure verticale.

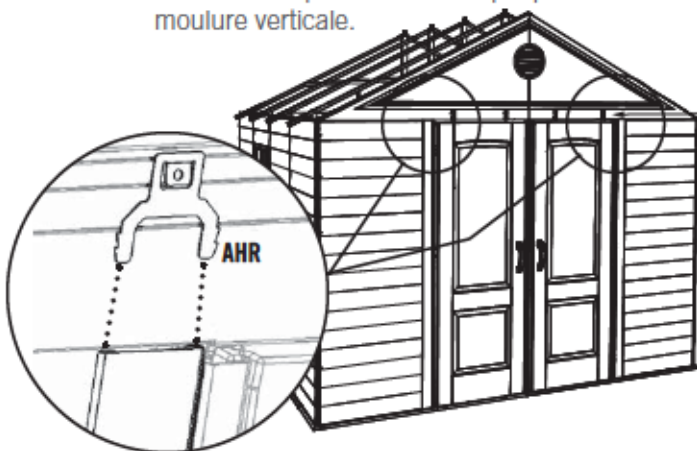

### 12.4

- Bend the tabs on the Clips outward a bit. Slide the piece of **Horizontal Trim (AGC)** over the Clips and Brackets as shown.
- Tuerza las lengüetas en los Clips hacia afuera un poco. Deslice la pieza de **Moldura horizontal (AGC)** sobre los Clips y los Soportes como se muestra.
- Plier les languettes des Clips vers l'extérieur un peu. Glissez la pièce de **Moulure horizontale (AGC)** sur les Clips et les Supports comme illustré.

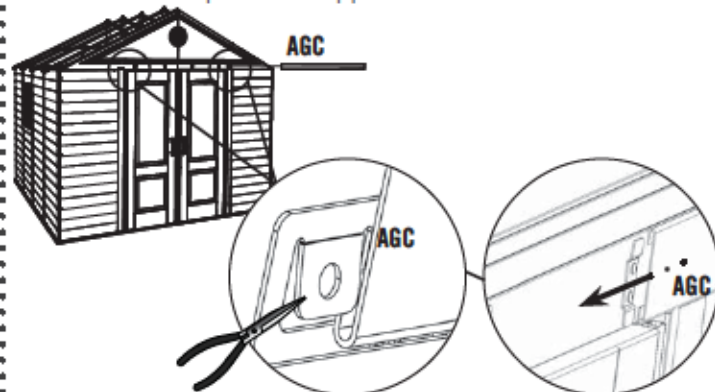

## ► SECTION 12 (CONTINUED) / SECCIÓN 12 (SIGUE) / SECTION 12 (SUITE)

TOOLS AND HARDWARE REQUIRED / HERRAMIENTAS Y ACCESORIOS REQUERIDOS / OUTILS ET ACCESSOIRES REQUIS

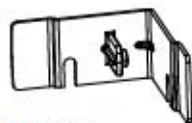

AGA (x24)



ADX (x48)



AYR (x4)

### 12.5

- Attach six (6) **Corner Brackets (AGA)** to each corner of the Shed (24 in all) as shown.
- Sujete seis (6) **Soportes angulares (AGA)** a cada esquina del cobertizo (24 en total) como se muestra.
- Attachez bien six (6) **Supports angulaires (AGA)** a chaque coin de l'abri (24 en tout) comme illustré.

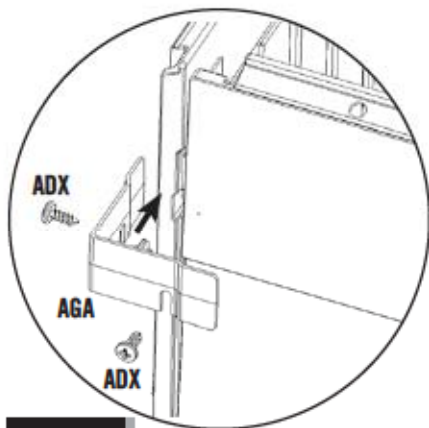

### 12.6

- Slide a piece of **Corner Trim (AQX)** down over the Corner Brackets of each corner as shown. Secure the Trim at the top with one (1) **Screw (AYR)**.
- Deslice una pieza de **Moldura angular (AQX)** sobre los Soportes angulares de cada esquina como se muestra. Sujete la Moldura al extremo superior con un (1) **Tornillo (AYR)**.
- Glissez une pièce de **Moulure angulaire (AQX)** sur les Supports angulaires de chaque coin comme illustré. Attachez le Moulure à l'extrémité supérieure à l'aide d'une (1) **Vis (AYR)**.

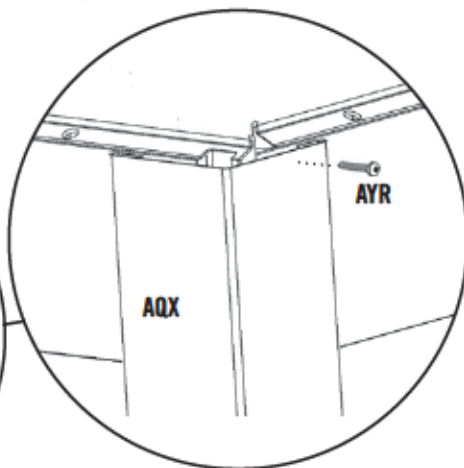
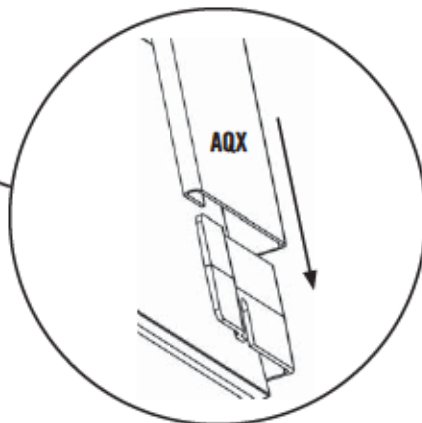
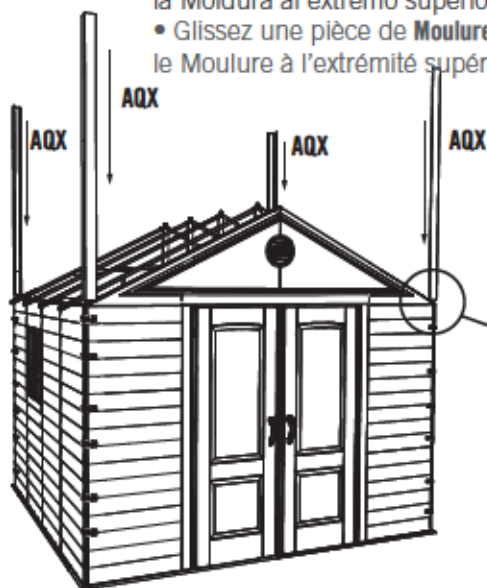



### HARDWARE REQUIRED / ACCESORIOS REQUERIDOS / ACCESSOIRES REQUIS

Hardware Bags / Bolsas de accesorios / Sacs d'accessoires



ADX (x4)



ADZ (x185)



ACJ (x16)



ACF (x1)

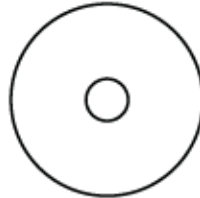

AED (x16)



ADK (x1)

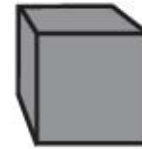

AJA (x20)



### PARTS REQUIRED / PIEZAS REQUERIDAS / PIÈCES REQUISES

Metal Parts / Piezas de metal / Pièces en métal

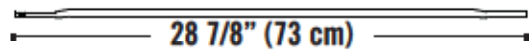

AFL (x18)

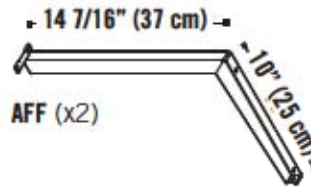

AFF (x2)

Plastic Parts / Piezas de plástico / Pièces en plastique

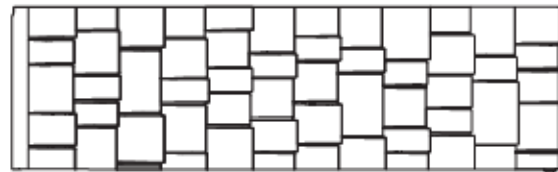

AGU (x2)

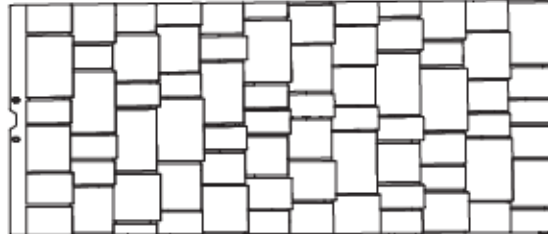

AGQ (x4)



AGE (x2)

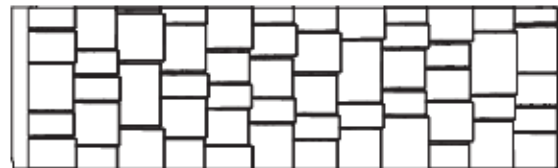

AGV (x2)

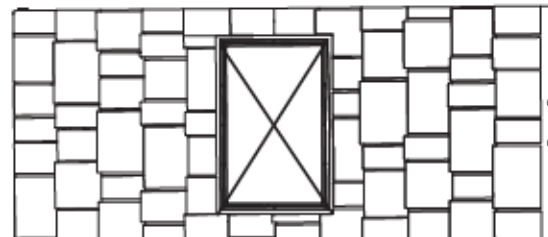

AHB (x2)



AFY (x3)



### TOOLS REQUIRED / HERRAMIENTAS REQUERIDAS / OUTILS REQUIS



3/8" (10 mm)



7/16" (11 mm)

## ► SECTION 13 (CONTINUED) / SECCIÓN 13 (SIGUE) / SECTION 13 (SUITE)

TOOLS AND HARDWARE REQUIRED / HERRAMIENTAS Y ACCESORIOS REQUERIDOS / OUTILS ET ACCESSOIRES REQUIS



ADZ (x24)

### 13.1

• Set a **Roof Panel (AGU)** down onto the Truss and front Gable. Align the holes in the Truss, Gable, and Wall Panel with those in the Roof Panel. Secure the Roof Panel using twelve (12) **Screws (ADZ)**.

• Coloque un **Panel de tejado (AGU)** sobre el Armazón y la Fachada delantera. Alinee los agujeros en el Armazón, la Fachada, y el Panel mural con ellos en el Panel de tejado. Sujete el Panel de tejado usando doce (12) **Tornillos (ADZ)**.

• Mettez un **Panneau de toit (AGU)** sur la Ferme et le Toit à pignon avant. Alignez les trous dans la Ferme, le Toit à pignon, et le Panneau mural avec ceux dans le Panneau de toit. Attachez le Panneau de toit à l'aide de douze (12) **Vis (ADZ)**.

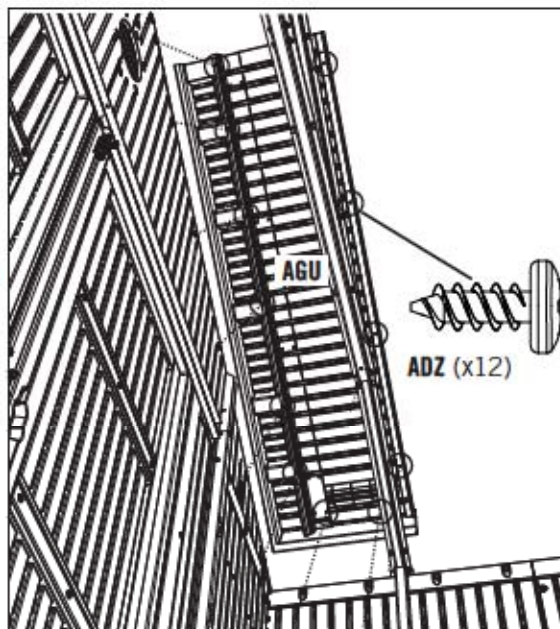

### 13.2

- Repeat this step for Roof Panel (AGV).
- Repita este paso para el Panel de tejado (AGV).
- Répétez cette étape pour un Panneau de toit (AGV).

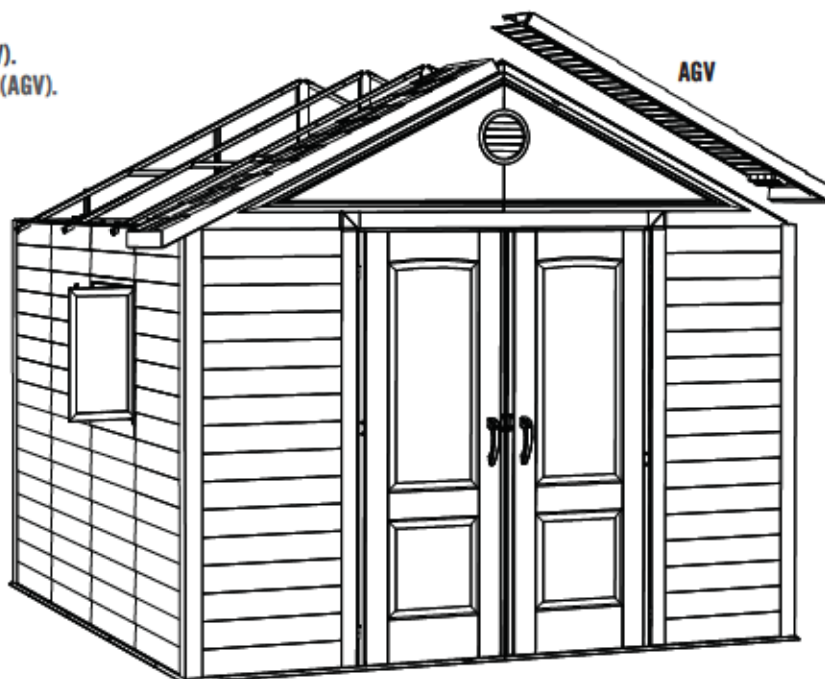

## ► SECTION 13 (CONTINUED) / SECCIÓN 13 (SIGUE) / SECTION 13 (SUITE)

TOOLS AND HARDWARE REQUIRED / HERRAMIENTAS Y ACCESORIOS REQUERIDOS / OUTILS ET ACCESSOIRES REQUIS

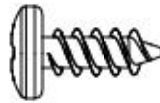

ADZ (x72)

### 13.3

- Insert three (3) **Roof Supports (AFL)** into the notches in of the **Roof Panels (AGQ or AHB)** as you insert the Screws into the Panel.
- Inserte tres (3) **Soportes de tejado (AFL)** en las muescas en los **Paneles de tejado (AGQ o AHB)** al insertar los Tornillos en el Panel.
- Insérez trois (3) **Supports de toit (AFL)** dans les encoches dans les **Panneaux de toit (AGQ ou AHB)** pendant que vous insérez les Vis dans le Panneau.

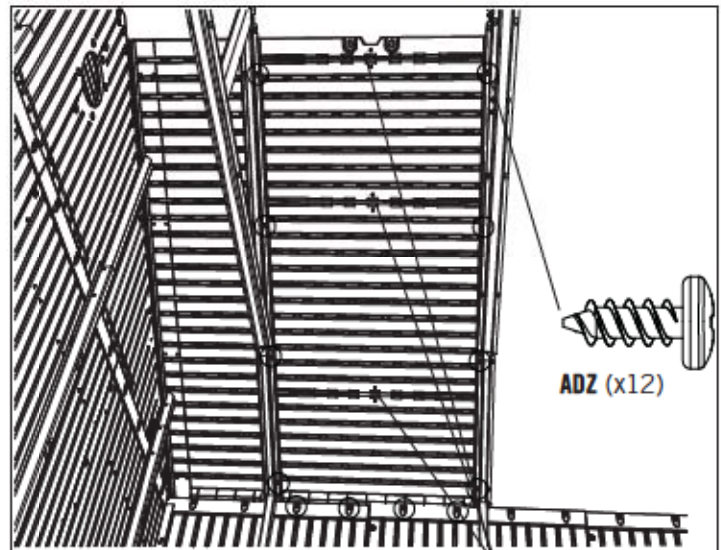
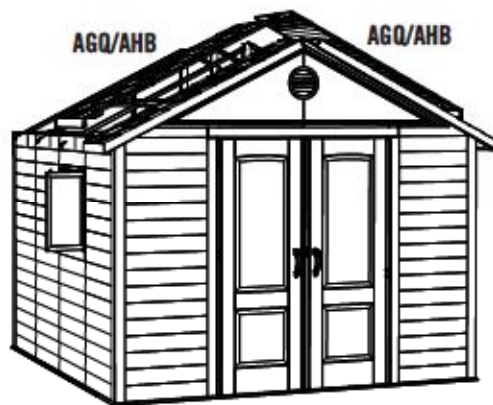

### 13.4

- Repeat the previous step for the next four **Roof Panels (AGQ or AHB)**.
- Repita el paso anterior para los próximos cuatro **Paneles de tejado (AGQ o AHB)**.
- Répétez l'étape précédente pour les quatre **Panneaux de toit (AGQ ou AHB)** suivantes.

28 7/8" (73 cm)

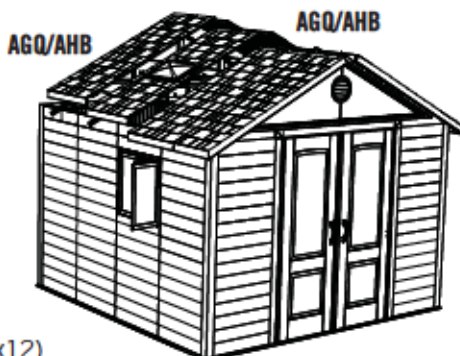

AFL (x12)

### 13.5

- Set a **Gable Assembly** onto the rear **Wall Panels**. Align the holes in the **Wall Panels** with those in the **Gable**.
- Alinee los agujeros en los **Paneles murales** con ellos en la **Fachada**. Coloque un **Conjunto de fachada** en los **Paneles murales traseros**.
- Aligned les trous dans les **Panneaux muraux** avec ceux dans le **Toit à pignon**. Mettez l'**Ensemble de toit à pignon** sur les **Panneaux muraux arrière**.



## ► SECTION 13 (CONTINUED) / SECCIÓN 13 (SIGUE) / SECTION 13 (SUITE)

TOOLS AND HARDWARE REQUIRED / HERRAMIENTAS Y ACCESORIOS REQUERIDOS / OUTILS ET ACCESSOIRES REQUIS



ADZ (x40)

### 13.6

- Secure the Gable with sixteen (16) **Screws (ADZ)**. Secure the Gable to the Wall Support Channels using six (6) **Screws (ADZ)**.
- Sujete la Fachada usando dieciséis (16) **Tornillos (ADZ)**. Sujete la Fachada a los Soportes murales usando seis (6) **Tornillos (ADZ)**.
- Attachez le Toit à pignon à l'aide de seize (16) **Vis (ADZ)**. Attachez le Toit à pignon aux Supports muraux à l'aide de six (6) **Vis (ADZ)**.

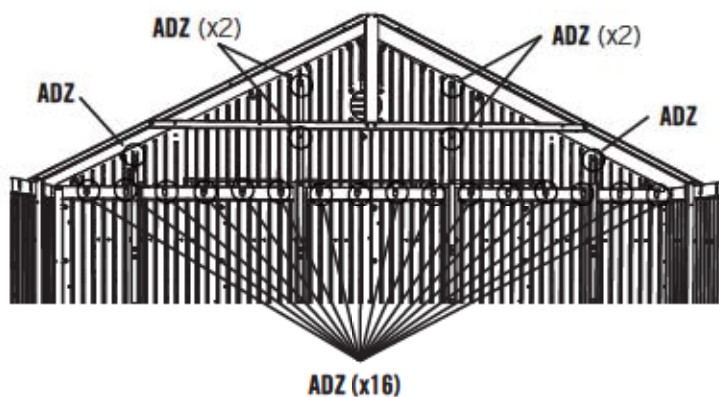

### 13.7

- Attach the last to **Outer Roof Panels (AGU & AGV)** like the first two.
- Sujete los dos últimos **Paneles de tejado exteriores (AGU y AGV)** como los primeros dos.
- Attachez les deux derniers **Panneaux de toit extérieurs (AGU et AGV)** comme les premiers deux.

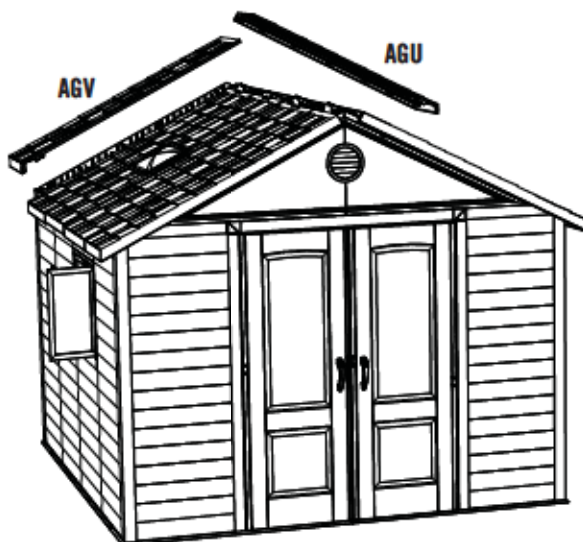

## ► SECTION 13 (CONTINUED) / SECCIÓN 13 (SIGUE) / SECTION 13 (SUITE)

TOOLS AND HARDWARE REQUIRED / HERRAMIENTAS Y ACCESORIOS REQUERIDOS / OUTILS ET ACCESSOIRES REQUIS

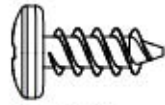

ADZ (x20)

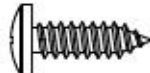

ACJ (x12)

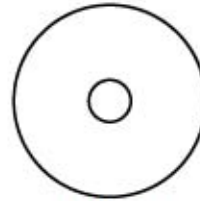

AED (x12)

### 13.8

- Starting at the front of the shed, attach the **Roof Caps (AGE & AFY)** using the hardware provided.
- Empezando a la parte delantera del cobertizo, sujete las **Cumbreras de tejado (AGE y AFY)** usando los accesorios provistos.
- En commençant à la partie avant de l'abri, attachez les **Capuchons de toit (AGE et AFY)** à l'aide des accessoires fournis.

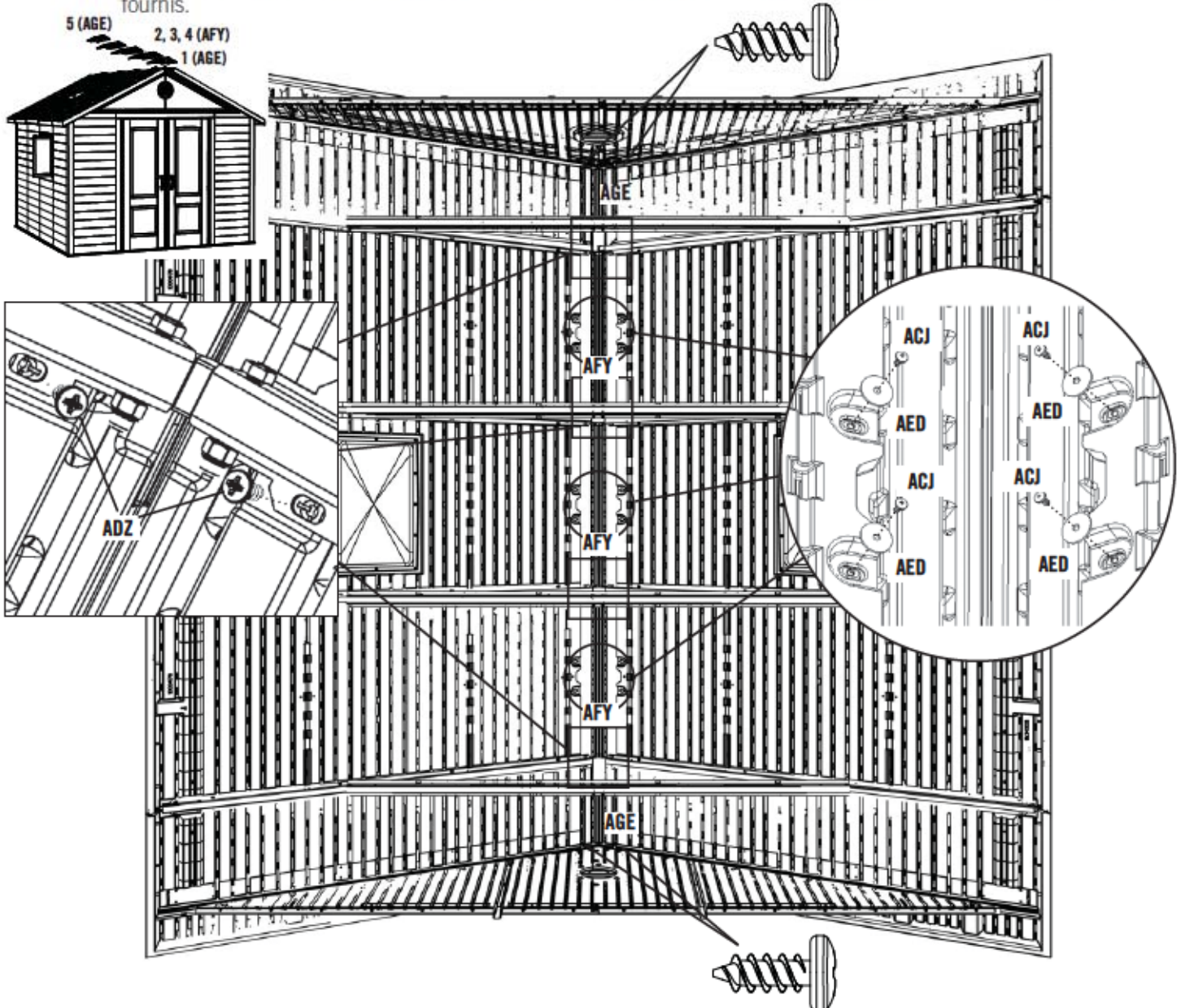

## ► SECTION 13 (CONTINUED) / SECCIÓN 13 (SIGUE) / SECTION 13 (SUITE)

TOOLS AND HARDWARE REQUIRED / HERRAMIENTAS Y ACCESORIOS REQUERIDOS / OUTILS ET ACCESSOIRES REQUIS



7/16" (x2)  
(11 mm) (x2)

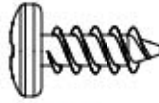

ADZ (x4)

### 13.9

- Attach the two (2) **Roof End Caps (AHA)** to the front and rear of the shed using two (2) **Screws (ADZ)** each.
- Sujete las dos (2) **Fachadas de tejado (AHA)** a las partes delantera y trasera del cobertizo usando dos (2) **Tornillos (ADZ)** cada uno.
- Attachez les deux (2) **Façades de toit (AHA)** aux parties avant et arrière de l'abri à l'aide de deux (2) **Vis (ADZ)** chaque un.

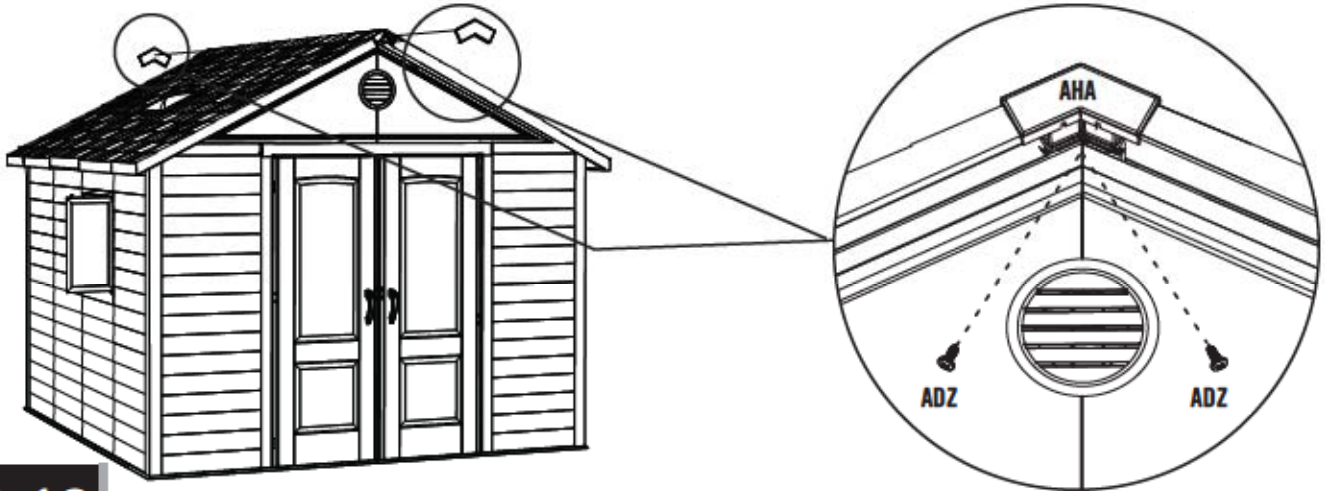

### 13.10

- Remove the Bolts and Nuts connecting the Horizontal Truss Brace to the Vertical Truss Brace.
- Retire los Pernos y Tuercas que sujetan el Soporte horizontal del armazón a los Soportes verticales del armazón.
- Soulevez les Boulons et Écrous qui attachent le Support horizontal de la ferme aux Supports verticaux de la ferme.

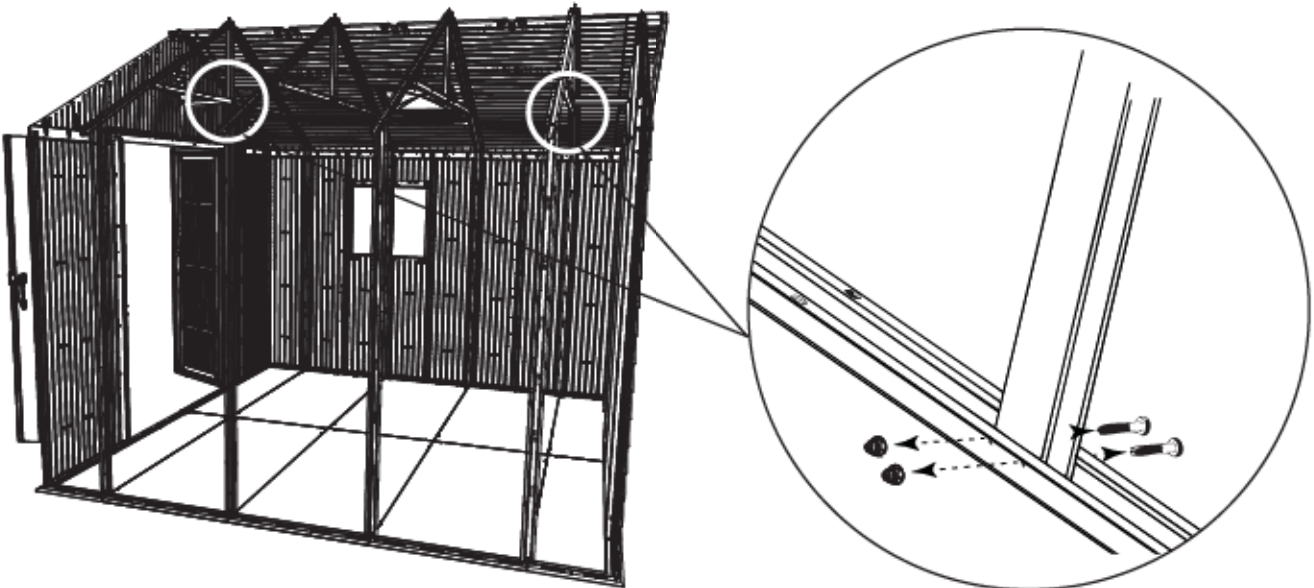

## ► SECTION 13 (CONTINUED) / SECCIÓN 13 (SIGUE) / SECTION 13 (SUITE)

TOOLS AND HARDWARE REQUIRED / HERRAMIENTAS Y ACCESORIOS REQUERIDOS / OUTILS ET ACCESSOIRES REQUIS



### 13.11

- Attach the **Angle Brackets (AFF)** to the Truss as shown. Then, attach the Brackets to the Gables using two (2) **Screws (ADX)** each. Finally, attach the Bracket to the Header using one (1) **Screw (ACF)** and one (1) **Cap Nut (ADK)**.
- Sujete los **Soportes angulares (AFF)** al Armazón como se muestra. Entonces, sujete los Soportes angulares a las Fachadas usando dos (2) **Tornillos (ADX)** cada uno. Por último, sujete el Soporte al Dintel usando un (1) **Tornillo (ACF)** y una (1) **Tuerca ciega (ADK)**.
- Attachez les **Supports angulaires (AFF)** à la Ferme comme illustré. Ensuite, attachez les Supports aux Toits à pignon à l'aide de deux (2) **Vis (ADX)** chaque un. Enfin, attachez le Support angulaire au Linteau à l'aide d'un (1) **Vis (ACF)** et d'un (1) **Écrou à chape (ADK)**.

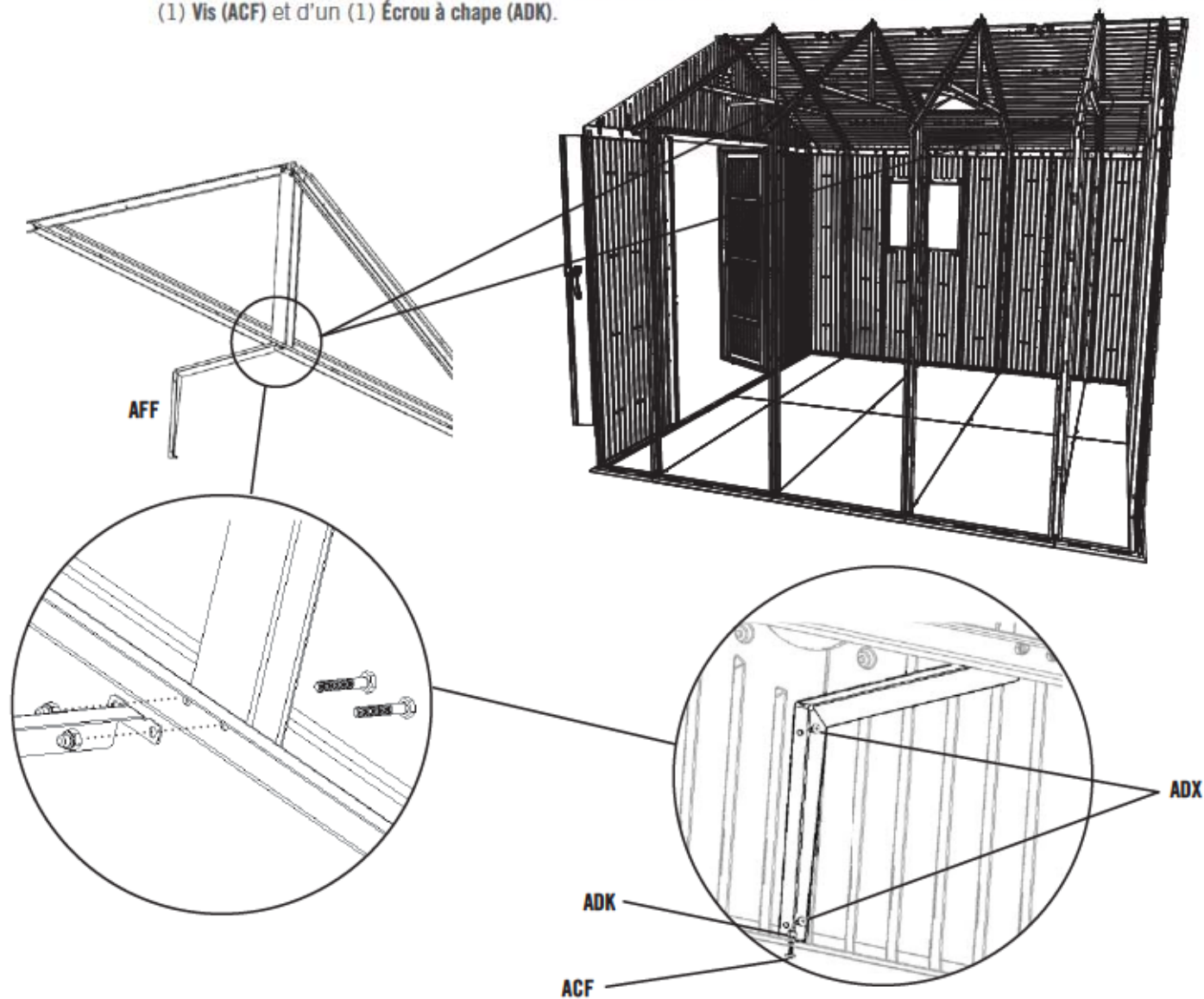

## ► SECTION 13 (CONTINUED) / SECCIÓN 13 (SIGUE) / SECTION 13 (SUITE)

TOOLS AND HARDWARE REQUIRED / HERRAMIENTAS Y ACCESORIOS REQUERIDOS / OUTILS ET ACCESSOIRES REQUIS



ADZ (x16)

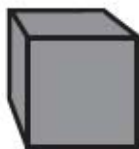

AJA (x16)

### 13.12

- Insert two (2) **Screws (ADZ)** through each Truss and into the Roof Panels.
- Inserte dos (2) **Tornillos (ADZ)** a través del Armazón y dentro de los Paneles de tejado.
- Insérez deux (2) **Vis (ADZ)** à travers la Ferme et dedans les Panneaux de toit.

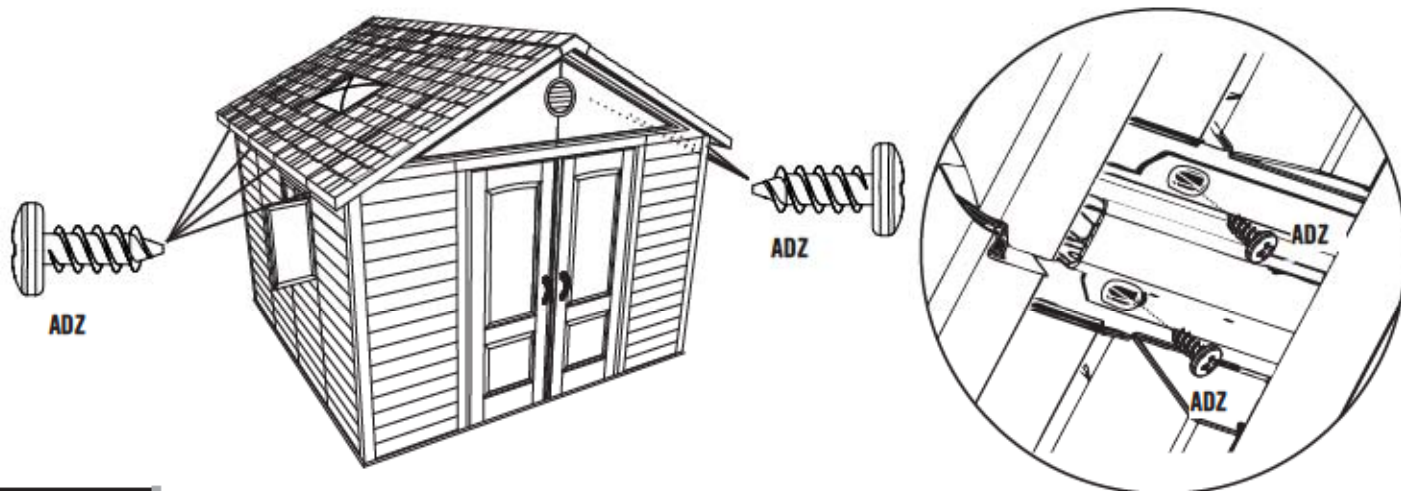

### 13.13

- Insert a **Foam Block (AJA)** into the spaces between the Trusses and the Wall Panels.
- Inserte un **Cubo de espuma (AJA)** en los espacios entre los Armazones y los Paneles murales.
- Insérez un **Cube en mousse (AJA)** dans les espaces entre les Fermes et les Panneaux muraux.

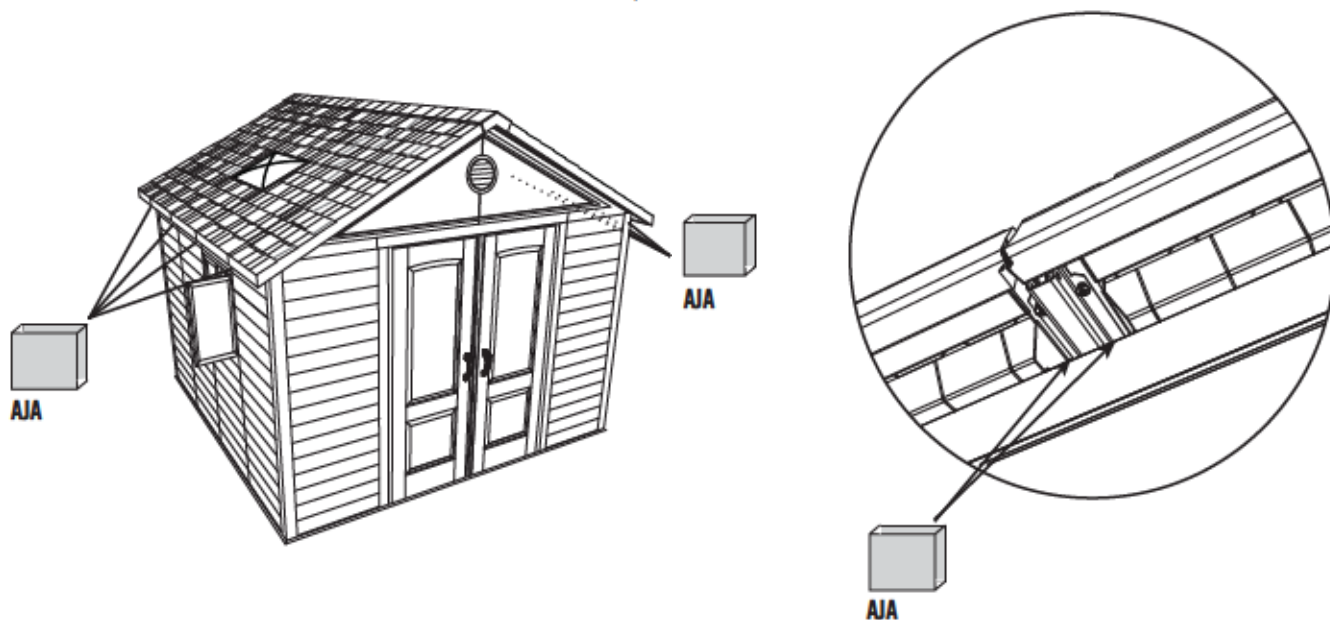



### HARDWARE REQUIRED / ACCESORIOS REQUERIDOS / ACCESSOIRES REQUIS

Hardware Bag / Bolsa de accesorios / Sac d'accessoires

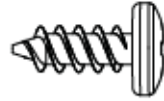

ADZ (x8)



ADW (x8)



ADX (x44)



AEE (x4)



ACF (x4)



ACB (x8)



ACD (x4)



ADK (x4)



AIE (x4)



AIN (x4)

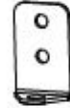

AIV (x4)



AIR (x8)



AIU (x8)

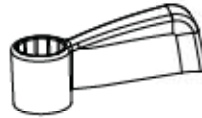

AIT (x8)



### PARTS REQUIRED / PIEZAS REQUERIDAS / PIÈCES REQUISES

Plastic Parts / Piezas de plástico / Pièces en plastique

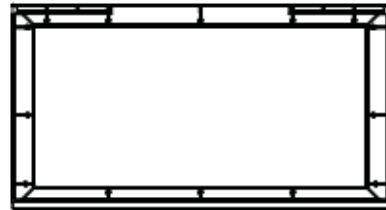

AHG (x4)

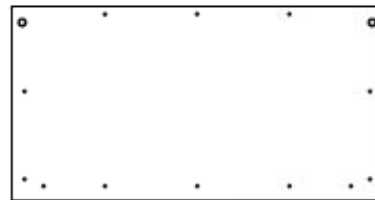

AHF (x4)



### TOOLS REQUIRED / HERRAMIENTAS REQUERIDAS / OUTILS REQUIS



3/8" (10 mm)

## ► SECTION 14 (CONTINUED) / SECCIÓN 14 (SIGUE) / SECTION 14 (SUITE)

TOOLS AND HARDWARE REQUIRED / HERRAMIENTAS Y ACCESORIOS REQUERIDOS / OUTILS ET ACCESSOIRES REQUIS



AIR (x8)

### 14.1

- Insert each **Hinge Tube (AIR)** up into the holes at the corners of each Window as shown.
- Introduzca cada **Tubo de bisagra (AIR)** dentro de los agujeros en las esquinas de cada Ventana como se muestra.
- Insérez chaque **Tube de charnière (AIR)** dans les trous aux coins de chaque Fenêtre comme illustré.

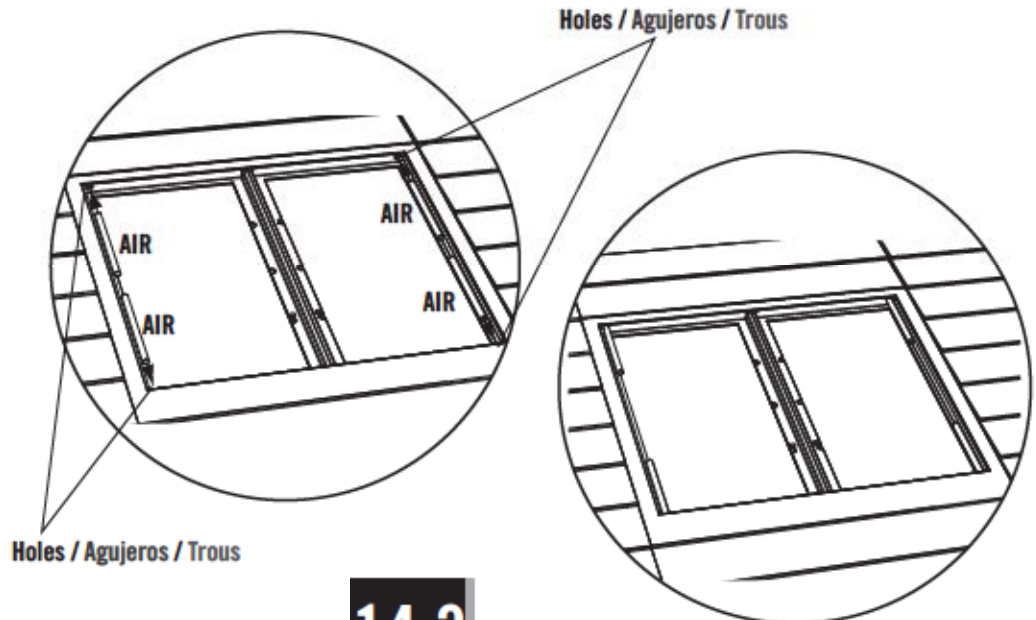
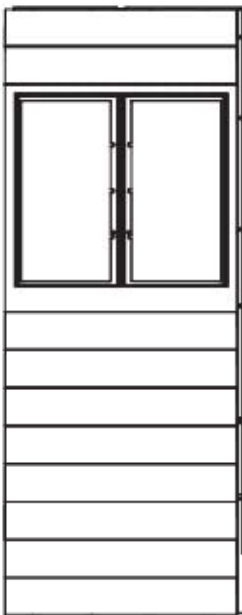

### 14.2

- Peel off the protective backing from both sides of the **Window (AHF)**. Repeat this step for the second Window.
- Retire la capa protectora de las dos caras de la **Ventana (AHF)**. Repita este paso para la segunda Ventana.
- Soulevez la pellicule protectrice des deux côtés de la **Fenêtre (AHF)**. Répétez cette étape pour la deuxième Fenêtre.

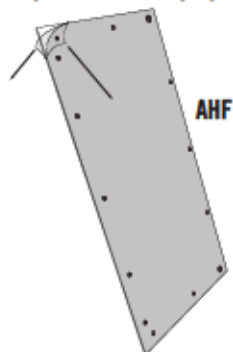

### 14.3

- Repeat this step for the second Window.
- Repita este paso para la segunda Ventana.
- Répétez cette étape pour la deuxième Fenêtre.

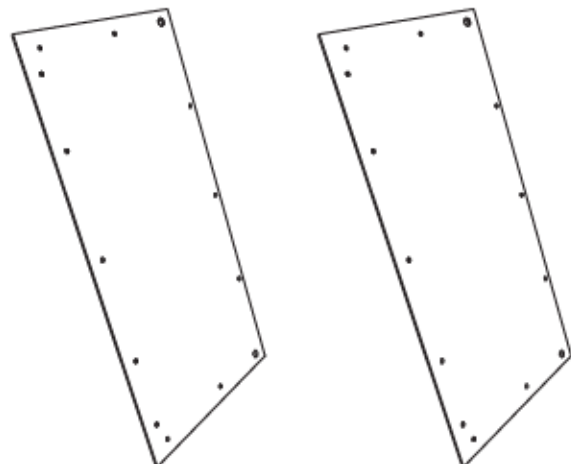

## ► SECTION 14 (CONTINUED) / SECCIÓN 14 (SIGUE) / SECTION 14 (SUITE)

TOOLS AND HARDWARE REQUIRED / HERRAMIENTAS Y ACCESORIOS REQUERIDOS / OUTILS ET ACCESSOIRES REQUIS



### 14.4

- Place a **Window Frame (AHG)** over a set of Hinge Tubes as shown.
- Coloque un **Marco de ventana (AHG)** sobre un juego de Bisagras como se muestra.
- Mettez un **Cadre de fenêtre (AHG)** sur un jeu de Charnières comme illustré.

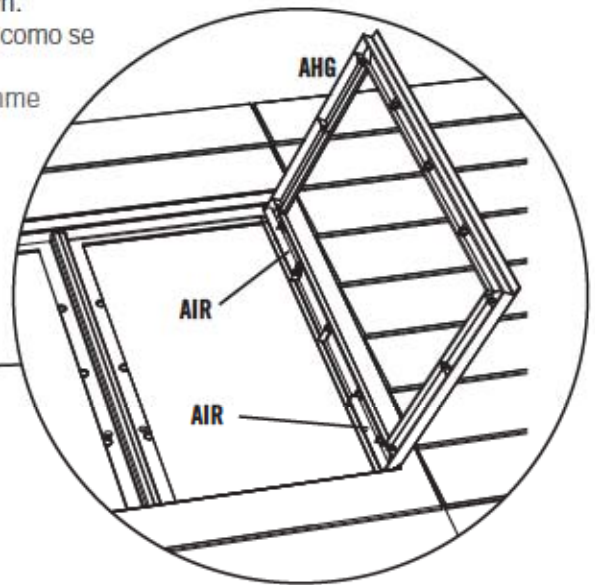
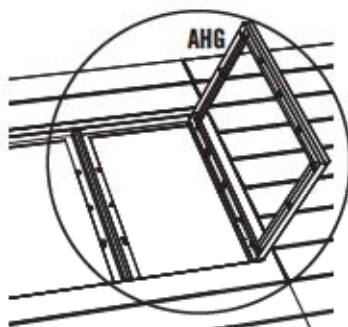
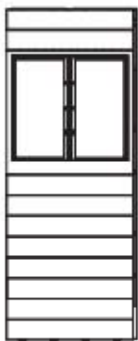

### 14.5

- Repeat the last step for the second Frame.
- Repita el paso anterior para el segundo Marco.
- Répétez l'étape précédente pour le deuxième Fenêtre.

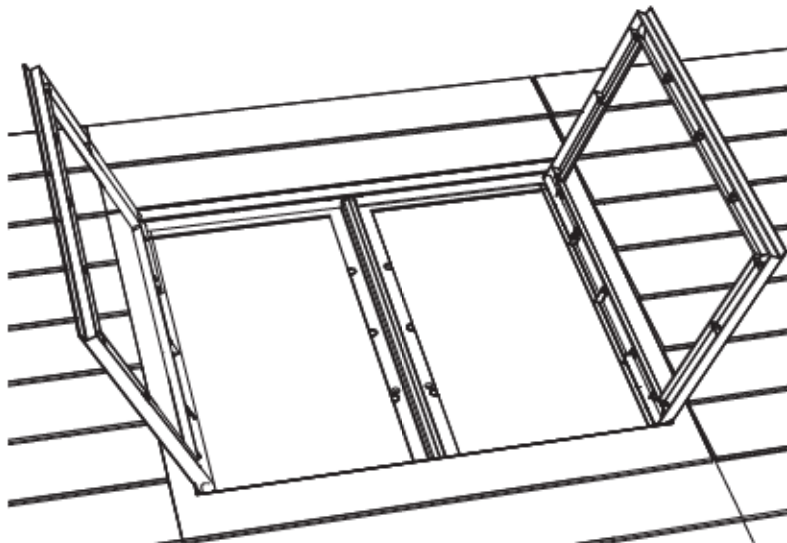

## ► SECTION 14 (CONTINUED) / SECCIÓN 14 (SIGUE) / SECTION 14 (SUITE)

TOOLS AND HARDWARE REQUIRED / HERRAMIENTAS Y ACCESORIOS REQUERIDOS / OUTILS ET ACCESSOIRES REQUIS



ADX (x40)

### 14.6

- Attach the Windows to the Frames only at the locations shown.
- Sujete las Ventanas a los Marcos sólo a las ubicaciones ilustradas.
- Attachez les Fenêtres aux Cadres seulement aux emplacements illustrés.

Windows / Ventanas / Fenêtres

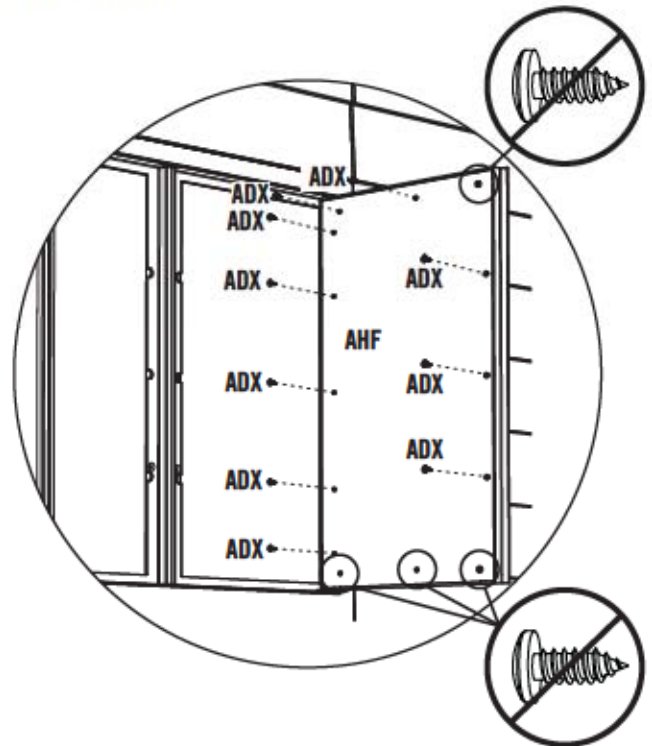
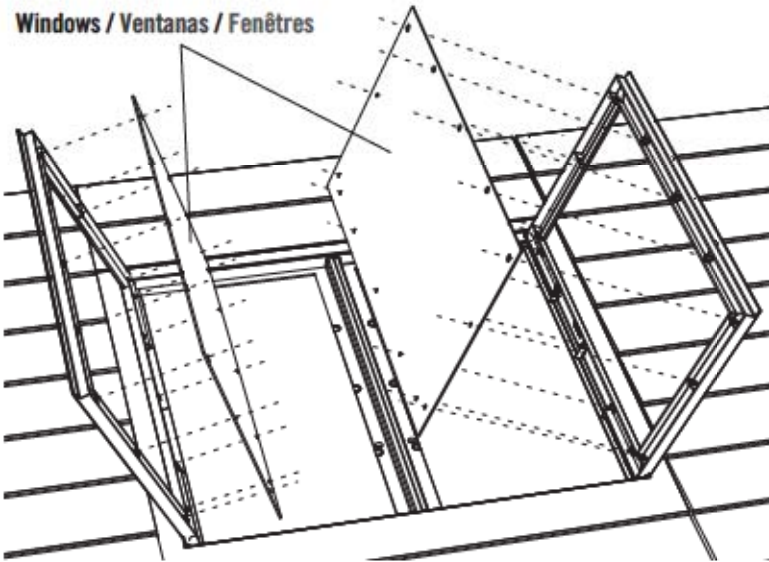

## ► SECTION 14 (CONTINUED) / SECCIÓN 14 (SIGUE) / SECTION 14 (SUITE)

TOOLS AND HARDWARE REQUIRED / HERRAMIENTAS Y ACCESORIOS REQUERIDOS / OUTILS ET ACCESSOIRES REQUIS

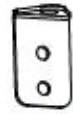

AIV (x4)

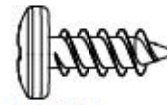

ADZ (x8)



AIE (x4)



ADW (x8)

### 14.7

- Attach a **Window Stay Bracket (AIV)** to each side of a Window Wall Panel as shown.
- Sujete un **Soporte para el limitador de apertura para la ventana (AIV)** a cada lado de un Panel mural para la ventana como se muestra.
- Attachez un **Support à limiteur d'ouverture de fenêtre (AIV)** à chaque côté d'un Panneau mural à fenêtre comme illustré.

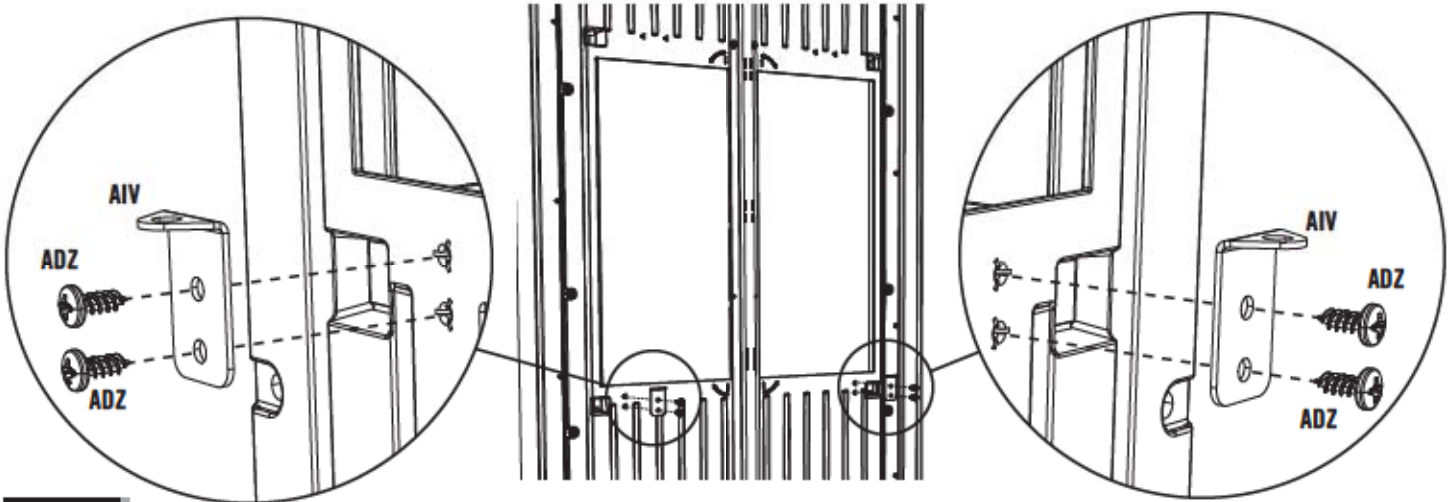

### 14.8

- Attach the **Window Stays (AIE)** to the Window Frames at the locations shown.
- Sujete los **Limitadores de apertura para la ventana (AIE)** a los Marcos de ventana a las ubicaciones ilustradas.
- Attachez les **Limiteur d'ouverture de fenêtre (AIE)** aux Cadres de fenêtre aux emplacements illustrés.

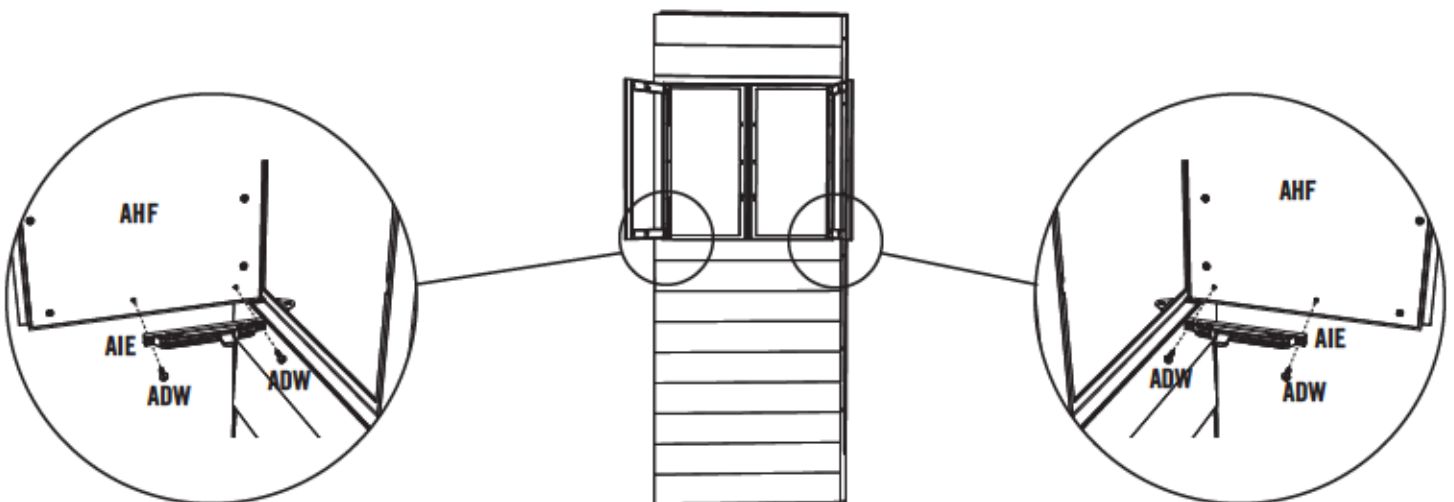

## ► SECTION 14 (CONTINUED) / SECCIÓN 14 (SIGUE) / SECTION 14 (SUITE)

TOOLS AND HARDWARE REQUIRED / HERRAMIENTAS Y ACCESORIOS REQUERIDOS / OUTILS ET ACCESSOIRES REQUIS



AIN (x4)



ACF (x4)



ADX (x4)



AEE (x4)

### 14.9

- Insert a Screw (ADX) into each Sliding Window Stay (AIN) as shown.
- Inserte un Tornillo (ADX) en cada Limitador corredizo de apertura para la ventana (AIN) como se muestra.
- Insérez une Vis (ADX) dans chaque Limiteur d'ouverture glissant de fenêtre (AIN) comme illustré.

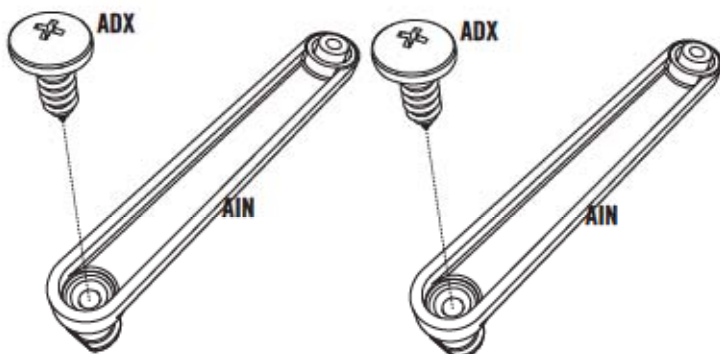

### 14.10

- Insert the Sliding Window Stay into Window Stay as shown. Repeat this step for a second Window Stay.
- Inserte un Limitador corredizo de apertura para la ventana en un Limitador de apertura para la ventana Stay como se muestra. Repita este paso para un segundo Limitador de apertura para la ventana.
- Insérez un Limiteur d'ouverture glissant de fenêtre dans un Limiteur d'ouverture de fenêtre comme illustré. Répétez cette étape pour un deuxième Limiteur d'ouverture de fenêtre.

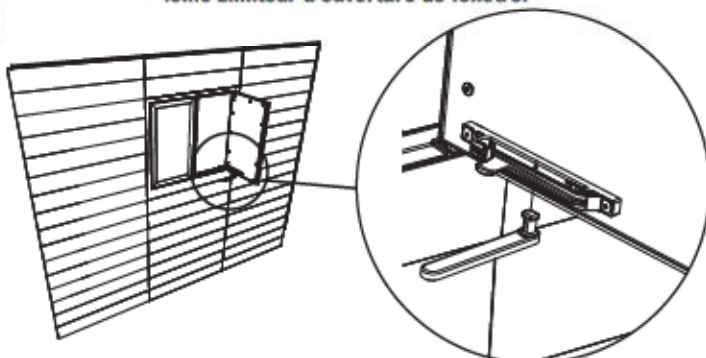

### 14.11

- Attach the Sliding Window Stays to the Sliding Window Stay Brackets as shown.
- Sujete el Limitador corredizo de apertura para la ventana al Soporte del limitador corredizo de apertura para la ventana como se muestra.
- Attachez le Limiteur d'ouverture glissant de fenêtre au Support au limiteur d'ouverture de fenêtre comme illustré.

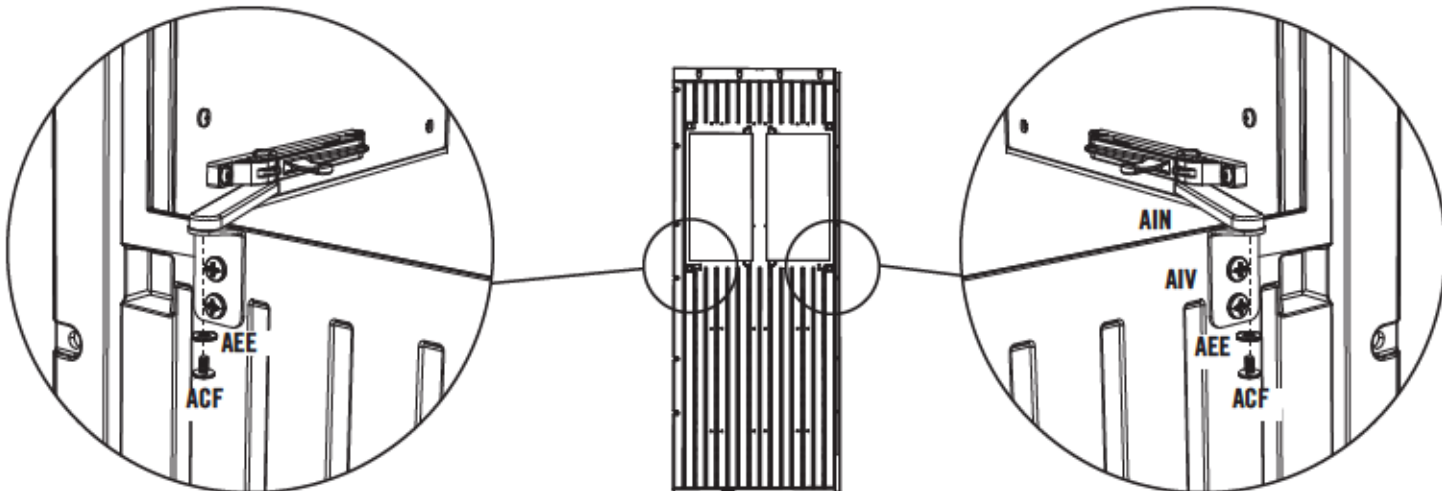

## ► SECTION 14 (CONTINUED) / SECCIÓN 14 (SIGUE) / SECTION 14 (SUITE)

TOOLS AND HARDWARE REQUIRED / HERRAMIENTAS Y ACCESORIOS REQUERIDOS / OUTILS ET ACCESSOIRES REQUIS



3/8"  
(10 mm)

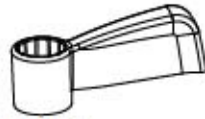

AIT (x8)



AIU (x8)

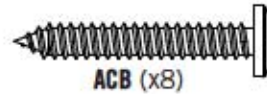

ACB (x8)



ACD (x4)



ADK (x4)

### 14.12

- Attach two **Window Latches (AIT)** to each Window Frame as shown.
- Sujete dos **Pestillo de ventana (AIT)** a cada Marco de ventana como se muestra.
- Attachez deux **Loquets de fenêtres (AIT)** à chaque Cadre de fenêtre comme illustré.

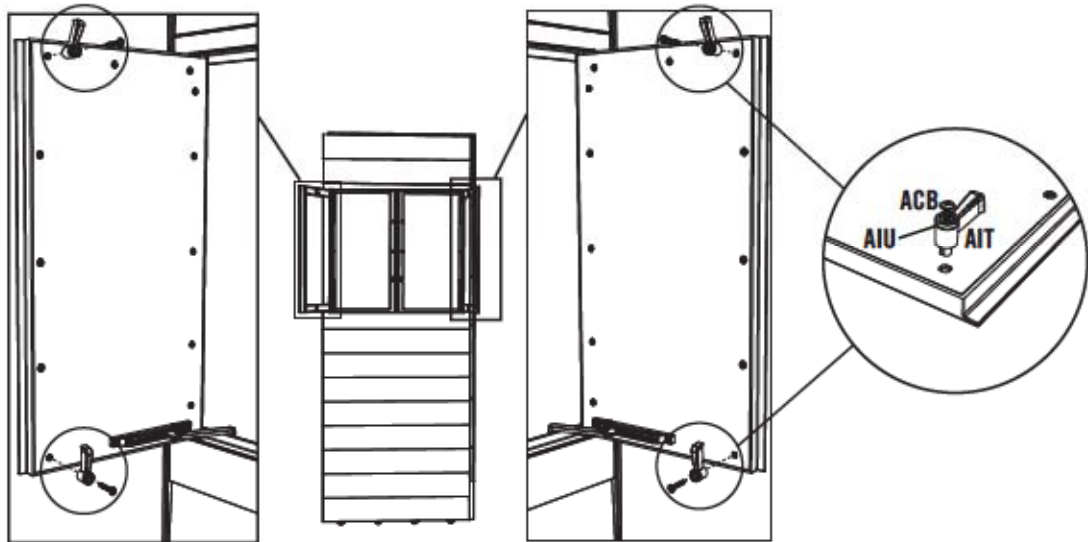

### 14.13

- Insert two **Screws (ACD)** through the two Window Wall Panels and Wall Support Channels. Secure each with a **Cap Nut (ADK)** as shown. **Do not overtighten the Nuts.**
- Inserte dos **Tornillos (ACD)** a través de los dos Paneles murales para la ventana y los Canales de soporte murales. Sujete cada Tornillo con una **Tuerca ciega (ADK)** como se muestra. **No apriete demasiado las Tuercas.**
- Insérez deux **Vis (ACD)** à travers les deux Panneaux muraux à fenêtre et les Canaux de support muraux. Attachez chaque Vis à l'aide d'un **Écrou à chape (ADK)** comme illustré. **Ne pas trop serrer les Écrous.**

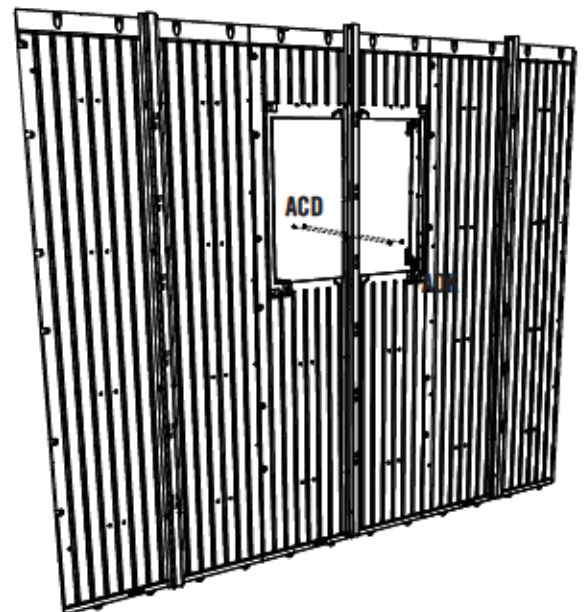

# 15

## PEGBOARD STRIP INSTALLATION / INSTALACIÓN DEL ORGANIZADOR DE HERRAMIENTAS / INSTALLATION DE L'ORGANISATEUR D'OUTILS



### HARDWARE REQUIRED / ACCESORIOS REQUERIDOS / ACCESSOIRES REQUIS

Hardware Bag / Bolsa de accesorios / Sac d'accessoires



ADW (x10)

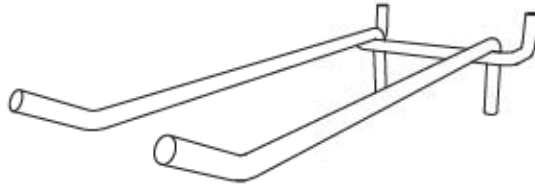

AIG (x1)

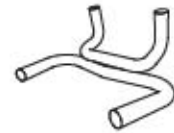

AU (x2)

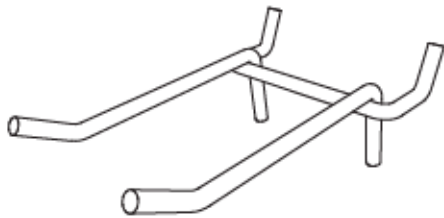

AIF (x1)



AIH (x3)



AII (x3)



### PARTS REQUIRED / PIEZAS REQUERIDAS / PIÈCES REQUISES

Plastic Parts / Piezas de plástico / Pièces en plastique



AFU (x2)



### TOOLS REQUIRED / HERRAMIENTAS REQUERIDAS / OUTILS REQUIS



## ► SECTION 15 (CONTINUED) / SECCIÓN 15 (SIGUE) / SECTION 15 (SUITE)

TOOLS AND HARDWARE REQUIRED / HERRAMIENTAS Y ACCESORIOS REQUERIDOS / OUTILS ET ACCESSOIRES REQUIS



ADW (x10)

### 15.1

- Attach the **Pegboard Strips (AFU)** to the Wall Panels using five (5) **Screws (ADW)** for each. **Try to avoid placing the holes in the Strip over grooves in the Wall Panels. They may be attached to the side Wall Panels also.**
- Sujete los **Organizadores de herramientas (AFU)** a los Paneles de pared usando cinco (5) **Tornillos (ADW)** cada uno. **Trate de evitar de situar los agujeros en el Organizador encima de las ranuras en los Paneles murales. Se los pueden sujetar también a los Paneles murales laterales.**
- Attachez les **Organiseurs d'outils (AFU)** aux Panneaux muraux à l'aide de cinq (5) **Vis (ADW)** chaque un. **Essayez d'éviter situer les trous dans l'Organisateur sur les rainures dans les Panneaux muraux. Vous pouvez les attacher également aux Panneaux muraux latéraux.**

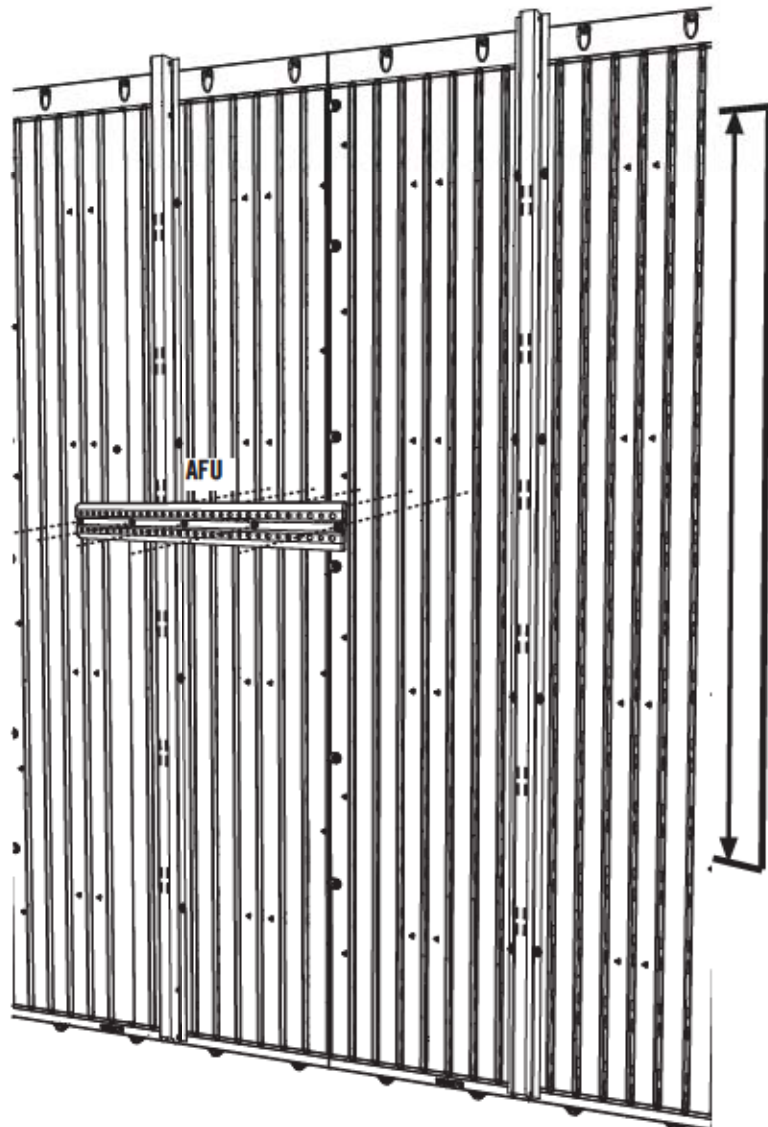

## ► SECTION 15 (CONTINUED) / SECCIÓN 15 (SIGUE) / SECTION 15 (SUITE)

TOOLS AND HARDWARE REQUIRED / HERRAMIENTAS Y ACCESORIOS REQUERIDOS / OUTILS ET ACCESSOIRES REQUIS

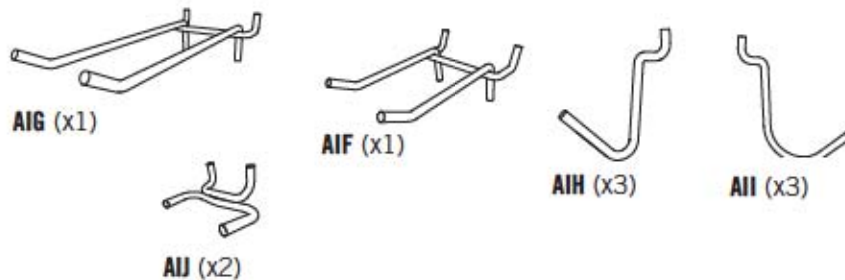

### 15.3

- Insert the various **Hooks (AIF, AIG, AIH, AII, AIJ)** as shown.
- Inserte los varios **Ganchos (AIF, AIG, AIH, AII, AIJ)** como se muestra.
- Insérez les divers **Crochets (AIF, AIG, AIH, AII, AIJ)** comme illustré.

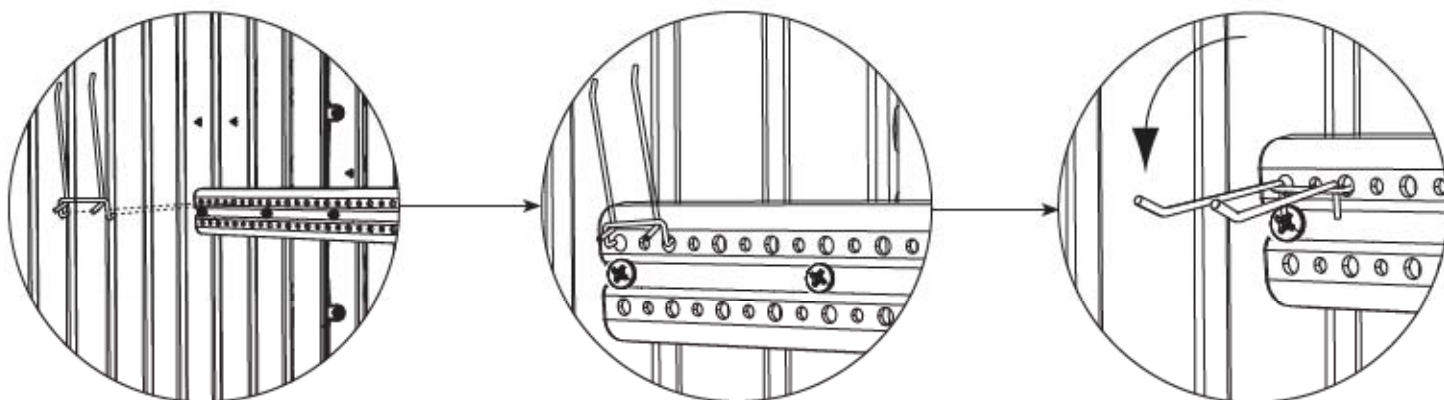

### 15.4

- Repeat this section for the second Pegboard Strip.
- Repita esta sección para el segundo Organizador de herramientas.
- Répétez cette section pour le deuxième Organisateur d'outils.

# 16

## DOOR ALIGNMENT / ALINEACIÓN DE LAS PUERTAS / ALIGNEMENT DES PORTES



### HARDWARE REQUIRED / ACCESORIOS REQUERIDOS / ACCESSOIRES REQUIS

**NO HARDWARE INCLUDED FOR THIS SECTION  
NINGÚN ELEMENTO INCLUIDO PARA ESTA SECCIÓN  
AUCUN ACCESSOIRE INCLUS POUR CETTE SECTION**



### PARTS REQUIRED / PIEZAS REQUERIDAS / PIÈCES REQUISES

**NO PARTS INCLUDED FOR THIS SECTION  
NINGUNA PIEZA INCLUIDA PARA ESTA SECCIÓN  
AUCUNE PIÈCE INCLUSE POUR CETTE SECTION**



### TOOLS REQUIRED / HERRAMIENTAS REQUERIDAS / OUTILS REQUIS



**7/16"  
(11 mm)**

## ► SECTION 16 (CONTINUED) / SECCIÓN 16 (SIGUE) / SECTION 16 (SUITE)

TOOLS AND PARTS REQUIRED / HERRAMIENTAS Y PIEZAS REQUERIDOS / OUTILS ET PIÈCES REQUIS



7/16"  
(11 mm)

### 16.1

- If the Doors are not parallel with one another, do the following:
- Si las Puertas no están paralelas la una con la otra, haga lo siguiente:
- Si les Portes ne sont pas parallèles l'une avec l'autre, faites les étapes suivantes :

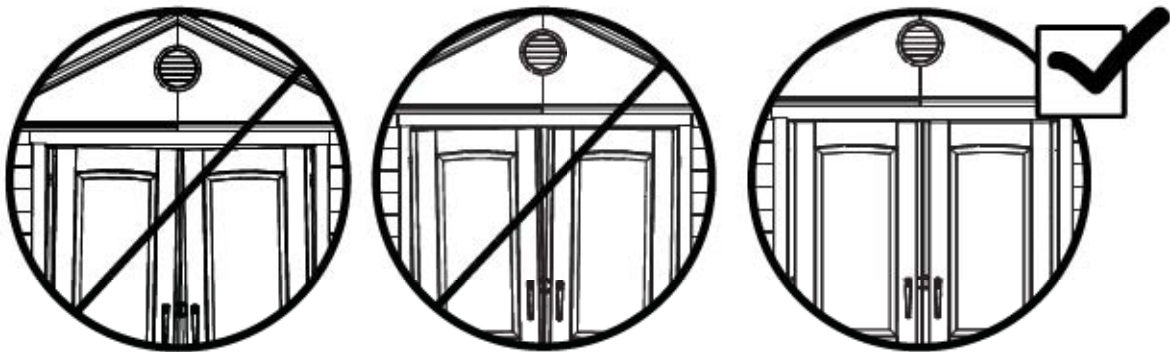

### 16.2

- Loosen the two Cap Nuts on the Door Header above the Hinges a 1/2 turn.
- Afloje las dos Tuercas ciegas en el Dintel encima de las Bisagras una media vuelta.
- Deserrez les deux Écrous à chape sur le Linteau au-dessus des Charnières.

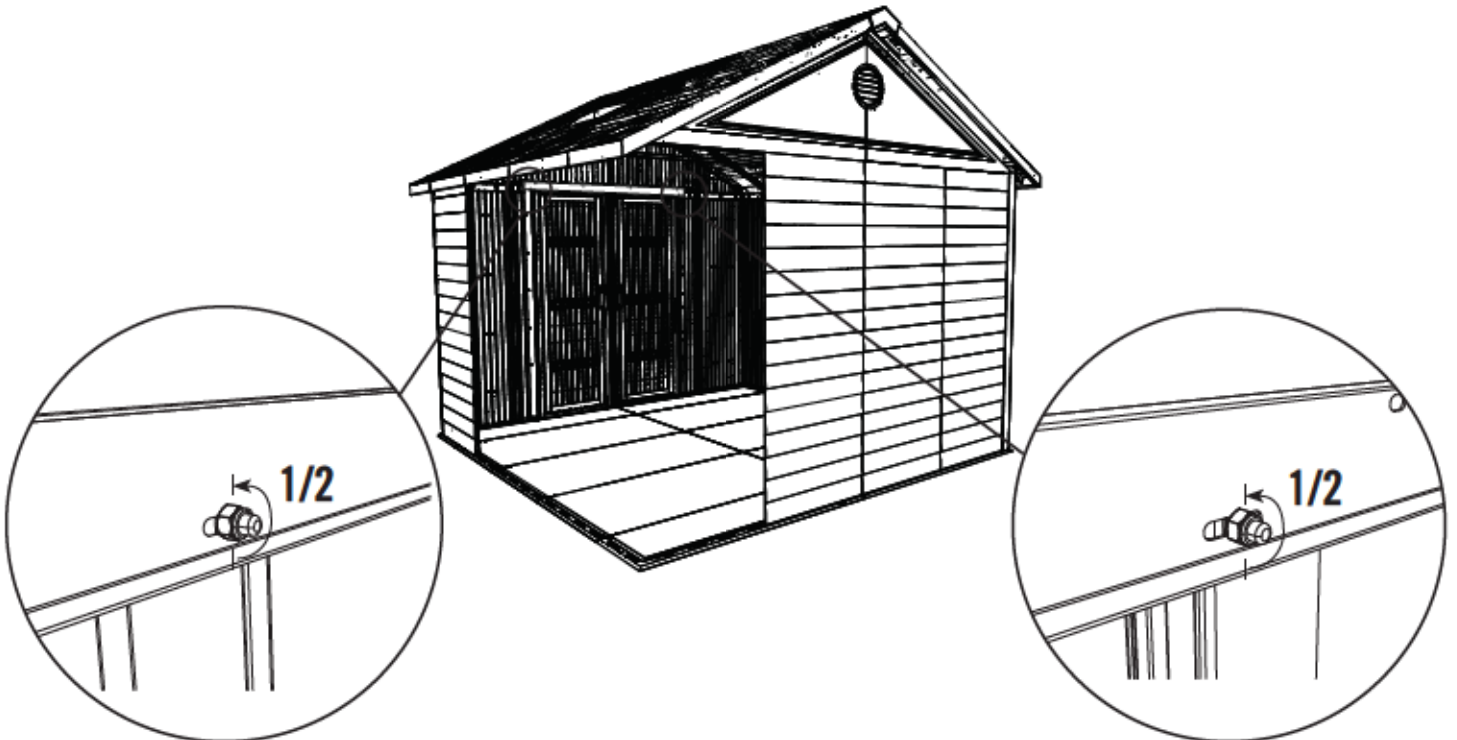

## ▶ SECTION 16 (CONTINUED) / SECCIÓN 16 (SIGUE) / SECTION 16 (SUITE)

TOOLS AND PARTS REQUIRED / HERRAMIENTAS Y PIEZAS REQUERIDOS / OUTILS ET PIÈCES REQUIS



7/16"  
(11 mm)

### 16.3

- Loosen the Screws along the Hinges.
- Afloje los diez Tornillos a lo largo de las Bisagras.
- Deserrez les dix Vis le long des Charnières.



### 16.4

- Adjust the Doors so they're parallel and retighten hardware. **Do not overtighten.**
- Ajuste las Puertas para que estén paralelos y re-apriete los elementos. **No apriete demasiado.**
- Ajustez les Portes pour que soient parallèles et resserrez les accessoires. **Ne serrez pas trop.**

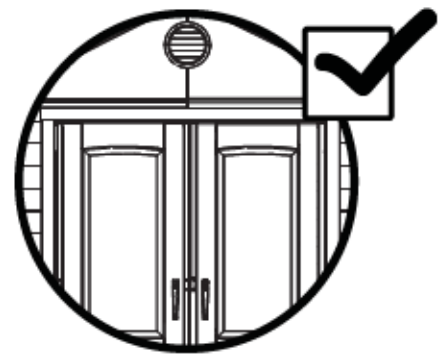
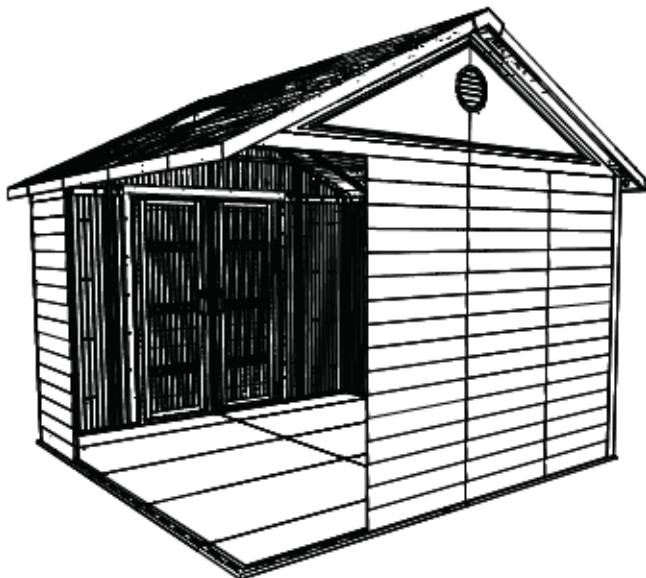

**HARDWARE REQUIRED / ACCESORIOS REQUERIDOS / ACCESSOIRES REQUIS**

*Hardware Bag / Bolsa de accesorios / Sac d'accessoires*

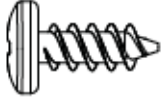

ADZ (x4)

**PARTS REQUIRED / PIEZAS REQUERIDAS / PIÈCES REQUISES**

**NO HARDWARE OR PARTS INCLUDED FOR THIS SECTION  
NINGÚN ELEMENTO O PIEZA INCLUIDO PARA ESTA SECCIÓN  
AUCUN ACCESSOIRE OU PIÈCE INCLUS POUR CETTE SECTION**

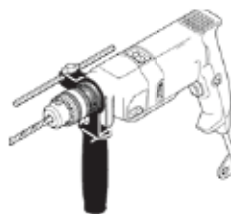
**TOOLS REQUIRED / HERRAMIENTAS REQUERIDAS / OUTILS REQUIS**

7/16" (11 mm)



5/16" (8 mm) Wood Drill Bit  
8 mm (5/16") Broca para madera  
8 mm (5/16") Foret à bois



5/16" (8 mm) Masonry Drill Bit  
8 mm (5/16") Broca para albañilería  
8 mm (5/16") Foret à maçonnerie

## ► SECTION 17 (CONTINUED) / SECCIÓN 17 (SIGUE) / SECTION 17 (SUITE)

FOR A CONCRETE PLATFORM / PARA UNA PLATAFORMA DE CONCRETO / POUR UNE PLATE-FORME EN BÉTON



ADZ (x4)

### 17.1

- Insert two (2) **Screws (ADZ)** through the Hinge-to-Floor Brackets and into the Floor at the bottom of the Hinges as shown. **Proceed to step 17.2 for the anchoring steps for the Wall Support Channels.**
- Inserte dos (2) **Tornillos (ADZ)** a través de los Soportes de bisagra-a-piso y dentro del Piso al extremo inferior de las Bisagras como se muestra. **Continue al paso 17.2 para ver como anclar los Soportes murales.**
- Insérez deux (2) **Vis (ADZ)** à travers les Supports de charnière-à-plancher et dans le Plancher a la partie inférieure des Charnières comme illustré. **Continuez à l'étape 17.2 pour voir comment ancrer les Supports muraux.**

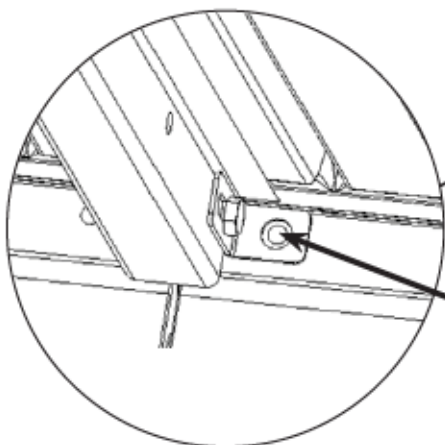
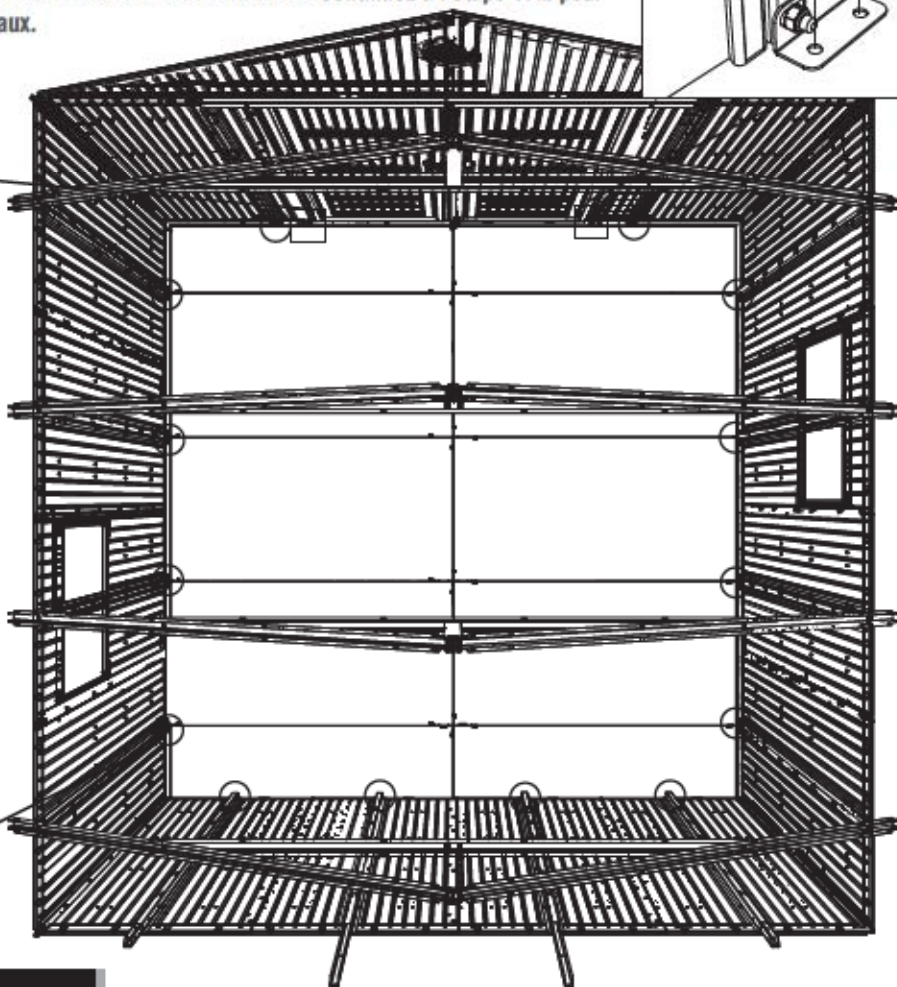
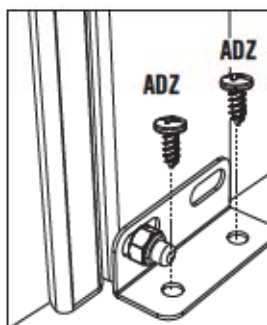
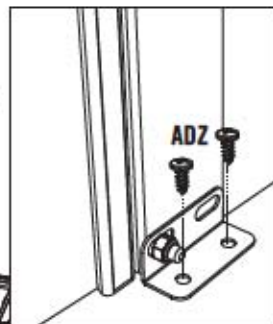

### 17.2

## ▶ SECTION 17 (CONTINUED) / SECCIÓN 17 (SIGUE) / SECTION 17 (SUITE)

FOR A CONCRETE PLATFORM / PARA UNA PLATAFORMA DE CONCRETO / POUR UNE PLATE-FORME EN BÉTON



### 17.2

- If you plan on anchoring your shed to a concrete platform, you must purchase the correct anchoring hardware. We recommend using a hammer drill, 5/16" (7,9 mm) masonry bit, fourteen (14) 3/8" x 2" (9,5 mm x 5,1 cm) Concrete Screws and fourteen (14) 3/8" x 1" (9,5 mm x 2,54 cm) Fender Washers.
- Si desea anclar su cobertizo a una plataforma hecho de concreto, es necesario comprar los elementos de anclaje correctos. Recomendamos que use un martillo perforador, broca de albañilería de 7,9 mm (5/16"), catorce (14) Tornillos de anclaje para concreto de 9,5 mm x 5,1 cm (3/8" x 2") y catorce (14) Rondanas de protección de 9,5 mm x 2,54 cm (3/8" x 1").
- Si vous désirez ancrer votre abri à une plate-forme en béton, il faut acheter les accessoires d'ancrage corrects. Nous recommandons que vous utilisiez une perceuse de percussion, un foret à maçonnerie de 7,9 mm (5/16"), quatorze (14) Vis d'ancrage à béton de 9,5mm x 5,1 cm (3/8" x 2") et quatorze (14) Rondelles de protection de 9,5mm x 2,54cm (3/8" x 1").



- **Do not exceed a 3/8" (10 mm) diameter screw. Refer to your local hardware store for this hardware.**
- **No exceda un diámetro de 10 mm (3/8"). Refiérase a su ferretería local para obtener estos elementos.**
- **Ne dépassez pas un diamètre de 10 mm (3/8"). Votre quincaillerie du coin aura ces accessoires.**

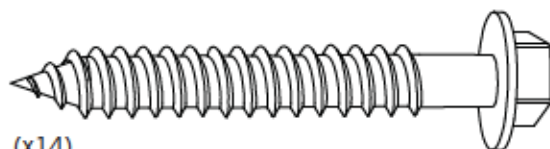

(x14)

(Not included) (No incluidas) (Pas incluses)

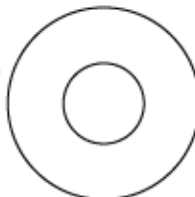

(x14)

(Not included) (No incluidas) (Pas incluses)



- Failure to anchor the shed may result in property damage and/or personal injury.
- El incumplimiento de anclar el cobertizo podría ocasionar daño a la propiedad y/o lesiones personales.
- Le non-respect d'ancrer votre abri peut résulter en dommage à propriété et/ou blessures graves personnelles.
- シェッドにアンカーを付けない場合は、物的損害や身体傷害が生じる可能性があります。

## ▶ SECTION 17 (CONTINUED) / SECCIÓN 17 (SIGUE) / SECTION 17 (SUITE)

FOR A CONCRETE PLATFORM / PARA UNA PLATAFORMA DE CONCRETO / POUR UNE PLATE-FORME EN BÉTON



5/16" (8 mm)



7/16" (11 mm)



### 17.2

- If you plan on anchoring your shed to a wood platform, you must purchase the correct anchoring hardware. We recommend using a drill, 5/16" (7,9 mm) drill bit, fourteen (14) 3/8" x 1 1/2" (9,5 mm x 3,81 cm) Lag Screws and fourteen (14) 3/8" x 1" (9,5 mm x 2,54 cm) Fender Washers.
- Si desea anclar su cobertizo a una plataforma hecho de madera, es necesario comprar los elementos de anclaje correctos. Recomendamos que use un taladro eléctrico, una broca de 7,9 mm (5/16"), catorce (14) Tornillos para madera de 9,5 mm x 3,81 cm (3/8" x 1 1/2") y catorce (14) Rondanas de protección de 9,5 mm x 2,54 cm (3/8" x 1").
- Si vous désirez ancrer votre abri à une plate-forme en bois, il faut acheter les accessoires d'ancrage corrects. Nous recommandons que vous utilisiez une perceuse électrique, un foret de 7,9 mm (5/16"), quatorze (14) Vis de retard de 9,5mm x 3,81 cm (3/8" x 1 1/2"), et quatorze (14) Rondelles de protection de 9,5mm x 2,54cm (3/8" x 1").



- **Do not exceed a 3/8" (10 mm) diameter screw. Refer to your local hardware store for this hardware.**
- **No exceda un diámetro de 10 mm (3/8"). Refiérase a su ferretería local para obtener estos elementos.**
- **Ne dépassez pas un diamètre de 10 mm (3/8"). Votre quincaillerie du coin aura ces accessoires.**

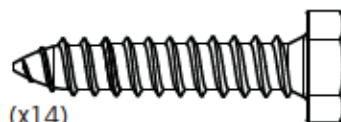

(x14)

(Not included) (No incluidas) (Pas incluses)

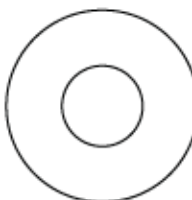

(x14)

(Not included) (No incluidas) (Pas incluses)

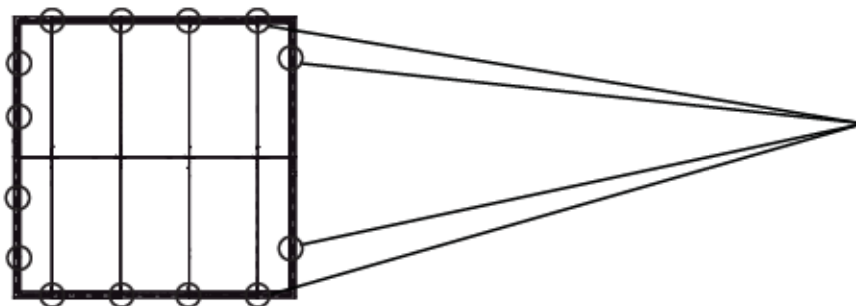

- Failure to anchor the shed may result in property damage and/or personal injury.
- El incumplimiento de anclar el cobertizo podría ocasionar daño a la propiedad y/o lesiones personales.
- Le non-respect d'ancrer votre abri peut résulter en dommage à propriété et/ou blessures graves personnelles.
- シェッドにアンカーを付けない場合は、物的損害や身体傷害が生じる可能性があります。



## CLEANING & CARE

**Congratulations on your Lifetime® product purchase. By following the instructions below, your new Lifetime product should provide you with years of service and enjoyment.**

The polyethylene panels are stain- and solvent-resistant. Most stains can be removed using a mild soap and a soft-bristled brush. Abrasive cleaning materials may scratch the plastic and are not recommended. Repair scratches or rust spots on the metal by sanding the affected area lightly; using a rust preventative spray primer; and finally, spraying with a high-gloss spray enamel paint. Avoid placing a direct heat source on or near surfaces unless using a heat barrier.



## LIMPIEZA Y CUIDADO

**Felicidades por la compra de su producto Lifetime®. Si cumple todas las instrucciones siguientes, podrá disfrutar satisfactoriamente del servicio de su nuevo producto Lifetime.**

Las paredes y los estantes de polietileno son resistentes a las manchas y al solvente. Use para su limpieza un jabón suave y un cepillo de cerdas blandas.

Los materiales limpiadores abrasivos podrían raspar el plástico y no son recomendados. Repare las raspaduras o zonas oxidadas de las piezas de metal lijando ligeramente el área afectada; aplique luego una impresión en aerosol para prevenir la formación de óxido; finalmente pinte con un esmalte brillante en aerosol. Evite colocar una fuente directa de calor sobre las superficies o cerca de ellas a menos que use una barrera contra el calor.



## NETTOYAGE ET ENTRETIEN

**Nous vous félicitons d'avoir acheté ce produit Lifetime®. En suivant les instructions ci-dessous, votre nouvel produit Lifetime devrait vous fournir des années de service et de plaisir.**

Les murs et les étagères en polyéthylène sont résistants aux tâches et solvants de nettoyage. Pour les nettoyer, servez-vous d'un savon doux et d'une brosse douce. Les produits abrasifs de nettoyage risquent d'égratigner le plastique et ne sont pas recommandés. Pour réparer les égratignures ou tâches de rouille sur le métal, frottez légèrement l'endroit affecté ou papier de verre, puis passez un couche de produit vaporisant préventif et enfin vaporisez une peinture émail brillant élevé. Évitez de placer une source de chaleur directe sur ou près des surfaces, ou protégez-les à l'aide d'une protection contre la chaleur.



## REGISTER YOUR PRODUCT ONLINE AT WWW.LIFETIME.COM

At Lifetime®, we are committed to providing innovative and quality products. While registering, you will have the opportunity to give us your feedback. Your input is valuable to us.

- You can also opt in to receive new product notifications or promotions.
- In the unlikely event of a product recall or safety modification, your registration provides the information we need to notify you directly.
- Registration is fast, easy, and completely voluntary.

### LIFETIME'S PROMISE TO YOU:

*Maintaining your privacy is our long-standing policy at Lifetime®. And you can rest assured that Lifetime® will not sell or provide your personal data to other third parties, or allow them to use your personal data for their own purposes.*

We invite you to read our privacy policy at [www.lifetime.com](http://www.lifetime.com)

**REGISTER today!**



## REGISTRE SU PRODUCTO EN LÍNEA EN WWW.LIFETIME.COM

À Lifetime®, estamos comprometidos a proporcionar productos de calidad e innovadores. Al registrar, tendrá la oportunidad de darnos su opinión. Su opinión es muy valiosa para nosotros.

- Se puede optar inclusión también para recibir notificaciones de nuevos productos o promociones.
- En el caso poco probable de una retirada de un producto o modificación de seguridad, su registro nos provee la información necesario de notificarle directamente.
- El registro es rápido, fácil, y completamente voluntario.

### LA PROMESA DE LIFETIME® A USTED:

*Mantener su privacidad, es nuestro viejo acuerdo político a Lifetime®. Y puede tener la seguridad de que Lifetime® no venderá ni proveerá sus datos personales a otros terceros, ni les permitirá usar sus datos personales para sus propias intenciones.*

Le invitamos a leer nuestra política de privacidad en [www.lifetime.com](http://www.lifetime.com)

**¡REGÍSTRELO hoy!**



## ENREGISTREZ VOTRE ARTICLE EN LIGNE CHEZ NOUS À WWW.LIFETIME.COM

À Lifetime®, nous sommes engagés à fournir des produits innovants et de qualité. Lors de l'enregistrement, vous aurez l'occasion de nous donner votre avis. Vos remarques sont précieuses pour nous.

- Vous pouvez aussi vous engager pour recevoir notifications d'articles nouveaux et promotions.
- En cas improbable de retrait de produit du marché ou de modification affectant la sécurité, votre enregistrement nous fournit l'information nécessaire de vous contacter directement.
- L'enregistrement est rapide, simple, et complètement volontaire.

### LA PROMESSE DE LIFETIME® À VOUS :

*À Lifetime®, l'entretien de votre confidentialité est notre politique de longue date. Et vous pouvez être sûr que Lifetime® ne vendra pas ni fournira pas vos données personnelles à d'autres tiers, ou les permettra d'utiliser vos données personnelles à leur propres fins.*

Nous vous invitons à lire notre politique de confidentialité à [www.lifetime.com](http://www.lifetime.com)

**ENREGISTREZ aujourd'hui !**



## 10-YEAR LIMITED FACTORY WARRANTY

**THE MANUFACTURER RESERVES THE RIGHT TO MAKE SUBSTITUTIONS TO WARRANTY CLAIMS IF PARTS ARE UNAVAILABLE OR OBSOLETE.**

1. Lifetime outdoor sheds are warranted to the original purchaser to be free from defects in material or workmanship for a period of ten years from the date of original retail purchase. The word "defects" is defined as imperfections that impair the use of the product. Defects resulting from misuse, abuse or negligence will void this warranty. This warranty does not cover defects due to improper installation, alteration or accident. This warranty does not cover damage caused by vandalism, rusting, "acts of nature" or any other event beyond the control of the manufacturer.
2. This warranty is nontransferable and is expressly limited to the repair or replacement of defective product. If the product is defective within the terms of this warranty, Lifetime Products, Inc. will repair or replace defective parts at no cost to the purchaser. Shipping charges to and from the factory or distribution center are not covered and are the responsibility of the purchaser. Labor charges and related expenses for removal, installation or replacement of the shed or its components are not covered under this warranty.
3. This warranty does not cover scratching or scuffing of the product that may result from normal usage. In addition, defects resulting from intentional damage, negligence, unreasonable use or hanging from the truss will void this warranty.
4. Liability for incidental or consequential damages is excluded to the extent permitted by law. While every attempt is made to embody the highest degree of safety in all equipment, freedom from injury cannot be guaranteed. The user assumes all risk of injury resulting from the use of this product. All merchandise is sold on this condition, and no representative of the company may waive or change this policy.
5. This product is not intended for institutional or commercial use; Lifetime Products, Inc. does not assume any liability for such use. Institutional or commercial use will void the warranty.
6. Our goods come with guarantees that cannot be excluded under the Australian Consumer Law. You are entitled to a replacement or refund for a major failure and for compensation for any other reasonably foreseeable loss or damage. You are also entitled to have the goods repaired or replaced if the goods fail to be of acceptable quality and the failure does not amount to a major failure.
7. This warranty is expressly in lieu of all other warranties, expressed or implied, including warranties of merchantability or fitness for use to extent permitted by Federal and state law. Neither Lifetime Products, Inc., nor any representative assumes any other liability in connection with this product. This warranty gives you specific legal rights, and you may also have other rights which vary from state to state.

**PLEASE INCLUDE YOUR DATED SALES RECEIPT AND PHOTOGRAPHS OF DAMAGED PARTS.**

REPORT PRODUCT DEFECTS IN WRITING TO:  
Lifetime Products, Inc., PO Box 160010 Clearfield, UT 84016-0010  
or call 1-800-225-3865 M-F 7 a.m. to 5 p.m. MST.

**REGISTER YOUR PRODUCT FOR QUICKER CUSTOMER SERVICE.**

Visit [www.lifetime.com](http://www.lifetime.com) or call 1-800-225-3865 to register your product today.

**FOR INTERNATIONAL WARRANTY CLAIMS:**

All warranty claims must be accompanied by a sales receipt. Report all warranty claims in writing to your regional sales support representative. Please include your dated sales receipt and photographs of damaged parts. To identify the representative for your region, please visit: [www.lifetime.com/international](http://www.lifetime.com/international)



[www.lifetime.com](http://www.lifetime.com)



## GARANTÍA DE FÁBRICA LIMITADA POR 10 AÑOS

**EL FABRICANTE SE RESERVA EL DERECHO DE HACER SUSTITUCIONES EN LOS ELEMENTOS REEMPLAZADOS BAJO GARANTÍA SI LAS PIEZAS NO ESTÁN DISPONIBLES O SON OBSOLETAS.**

1. El comprador original recibe la garantía de que los cobertizos Lifetime estarán libres de defectos de material o de mano de obra por un período de 10 años a contar desde la fecha de la compra original. La palabra "defectos" se define como imperfecciones que perjudican el uso del producto. Los defectos emergentes de un mal uso, abuso o negligencia invalidarán esta garantía. Esta garantía no cubre defectos debidos a una instalación o alteración incorrecta o a un accidente. Esta garantía no cubre daños causados por vandalismo, oxidación, "actos de la naturaleza" u otros eventos que estén más allá del control del fabricante.
2. Esta garantía es intransferible, y queda expresamente limitada a la reparación o reemplazo de los productos defectuosos. Si el producto se encuentra defectuoso dentro de los términos de esta garantía, Lifetime Products, Inc. reparará o reemplazará las piezas defectuosas sin costo alguno para el comprador. Los gastos de envío hacia y desde la fábrica no están cubiertos, y quedan bajo la responsabilidad del comprador.
3. Esta garantía no cubre raspaduras ni marcas en el producto que pueden resultar de su uso normal. Además, los defectos causados por daños intencionales, negligencia, uso irrazonable o por colgarse de las cabriadas invalidarán esta garantía.
4. La responsabilidad por daños incidentales o consecuentes queda excluida hasta el punto en que lo permita la ley. Si bien se hace el mayor esfuerzo posible para lograr el más alto grado de seguridad en todos nuestros equipos, no puede garantizarse la libertad de cualquier tipo de lesión. El usuario asume todos los riesgos de lesiones emergentes del uso de este producto. Toda nuestra mercadería se vende bajo esta condición, y ningún representante de la compañía puede anular ni cambiar esta política.
5. Este producto no está pensado para el uso institucional ni comercial; Lifetime Products, Inc. no asume ninguna otra responsabilidad en conexión con este producto. El uso institucional o comercial invalidará la garantía.
6. Esta garantía se otorga en reemplazo expreso de toda otra garantía, expresa o implícita, incluidas las garantías de comercialización o adaptación para el uso en la medida permitida por las leyes federales y estatales. Ni Lifetime Products, Inc., ni ninguno de sus representantes asume ninguna otra responsabilidad en conexión con este producto. Esta garantía le otorga derechos legales específicos, y usted puede tener otros derechos que varían de estado a estado.

### **NINGUNA GARANTÍA OFRECIDA POR EL FABRICANTE ES VÁLIDA EN MÉXICO**

#### **TODOS LOS RECLAMOS DE GARANTÍA DEBEN ESTAR ACOMPAÑADOS POR UN RECIBO DE COMPRA**

INFORME POR ESCRITO LOS DEFECTOS EN EL PRODUCTO A:

Por favor, incluya el recibo de compra fechado y fotografías de las piezas dañadas.

Lifetime Products, Inc., PO Box 160010 Clearfield, UT 84016-0010,

o llame al 1.800.225.3865 de lunes a viernes de 0700 hasta 1700 (Hora de las Montañas)

#### **REGISTRE SU PRODUCTO**

Visite nuestra página en Internet [www.lifetime.com](http://www.lifetime.com), o llame al 1.800.225.3865 para registrar su producto hoy.

#### **PARA RECLAMOS DE GARANTÍA INTERNACIONALES:**

Todos los reclamos de garantía deben estar acompañados por un recibo de compra. Informe por escrito todos los reclamos de garantía a su representante regional de ventas. Favor de incluir su recibo de compra fechado y fotografías de las piezas dañadas.

Para identificar el representante de su región, visite [www.lifetime.com/international](http://www.lifetime.com/international)



[www.lifetime.com](http://www.lifetime.com)



## GARANTIE DE FABRICATION LIMITÉE DE 10 ANS

### LE FABRICANT RÉSERVE LE DROIT DE FAIRE DES SUBSTITUTIONS EN CAS DE RECOURS EN GARANTIE SI LES PIÈCES NE SONT PAS DISPONIBLES OR SONT OBSOLÈTES

1. Les abris extérieurs Lifetime sont garantis à l'acheteur d'origine contre tous défauts de matériau ou de fabrication pendant une durée de dix ans à partir de la date d'achat d'origine. Le mot « défauts » signifie des défauts qui empêchent l'utilisation du produit. Les défauts résultant de mauvais usage, d'abus ou de négligence annulent cette garantie. Cette garantie ne couvre pas les dommages causés par le vandalisme, la rouille, « les calamités naturelles » ou tout autre événement en dehors du contrôle du fabricant.
2. Cette garantie n'est pas transférable et est expressément limitée à la réparation ou au remplacement du produit défectueux. Si le produit est déclaré défectueux selon les termes de cette garantie, Lifetime Products, Inc. réparera ou remplacera les parties défectueuses gratuitement pour l'acheteur. Les frais d'expéditions aller et retour de l'usine ne sont pas couverts et sont à la charge de l'acheteur. Les frais de main-d'œuvre et frais associés à l'enlèvement, au montage ou au remplacement de l'abri ou de ses composantes ne sont pas couverts par cette garantie.
3. Cette garantie ne couvre pas les égratignures ou éraillures du produits résultant d'une utilisation normale. Par ailleurs, les défauts résultant de dommages intentionnels, négligence, utilisation abusive ou suspension à partir de l'entretoise annulent cette garantie.
4. Toute responsabilité pour dommages incidents ou consécutifs est exclue dans la mesure permise par la loi. Bien que toutes les mesures aient été prises pour intégrer le plus haut degré de sécurité dans l'ensemble du matériel, l'impossibilité de blessure ne peut pas être garantie. L'utilisateur assume tous les risques de blessure résultant de l'utilisation de ce produit. L'ensemble de la marchandise est vendu en vertu de cette condition et aucune personne représentant la société ne peut déroger à cette politique, ni la modifier.
5. Ce produit n'est pas prévu pour l'usage institutionnel ni commercial; Lifetime Products, Inc. n'assume aucune responsabilité pour tel usage. L'utilisation institutionnelle ou commerciale annulera cette garantie.
6. Cette garantie remplace expressément toutes autres garanties, expresses ou tacites, y compris les garanties de commercialisation ou d'adaptation à un but particulier dans la mesure permise par les lois fédérales et des états. Ni Lifetime Products, Inc. ni aucun de ses représentants n'assume aucune autre responsabilité concernant ce produit. Cette garantie vous accorde des droits particuliers, et vous aurai peut-être des autres droites qui varient d'un état à l'autre.

#### **TOUS LES RECOURS EN GARANTIE DOIVENT ÊTRE ACCOMPAGNÉS DU REÇU DE VENTE.**

FAIRE PARVENIR UN RAPPORT PAR ÉCRIT DE DÉFECTUOSITÉ DU PRODUIT A :

Lifetime Products, Inc., PO Box 160010 Clearfield, UT 84016-0010  
ou appelez-nous au 1.800.225.3865 lundi à vendredi 0700 - 1700 (HNR)

#### **ENREGISTREZ VOTRE ARTICLE À :**

[www.lifetime.com](http://www.lifetime.com), ou appelez-nous au 1.800.225.3865 pour enregistrer votre article aujourd'hui.

#### **POUR RECOURS EN GARANTIE INTERNATIONAUX:**

Tous les recours en garantie doivent être accompagnés du reçu de vente. Faire parvenir un rapport par écrit de défectuosité du produit à votre représentant régional de ventes. Veuillez inclure votre reçu de vente daté et photographies des pièces endommagées. Pour identifier votre représentant régional, visitez [www.lifetime.com/international](http://www.lifetime.com/international)



[www.lifetime.com](http://www.lifetime.com)

**ENHANCE YOUR LIFETIME® PURCHASE BY ADDING ACCESSORIES OR OTHER GREAT PRODUCTS**

*To purchase accessories or other Lifetime® products, visit us at:*

***www.lifetime.com***

*Or call: 1-800-424-3865*

**MEJORE SU COMPRA LIFETIME® Y AÑADA ACCESORIOS U OTROS PRODUCTOS EXCELENTES**

*Para comprar accesorios u otros productos Lifetime® EUA, visítenos en:*

***www.lifetime.com***

*O llame al: 1.800.424.3865*

**AMÉLIOREZ VOTRE ACHAT LIFETIME® EN AJOUTANT DES ACCESSOIRES OU AUTRES PRODUITS**

*Pour acheter des accessoires ou autres produits Lifetime®, rendez-vous une visite à :*

***www.lifetime.com***

*Ou appelez-nous au 1.800.424.3865*

