

MANUAL TILL VÄXTHUS

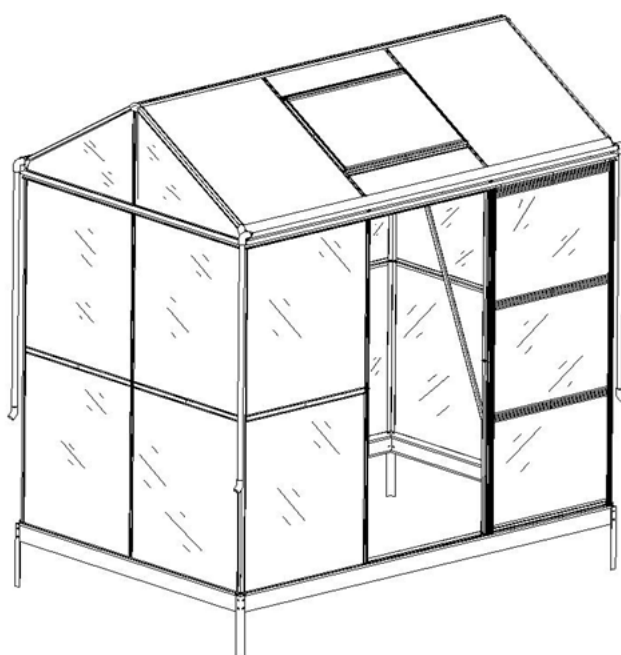

Modell: VG35

Råd om montering och underhåll

1. Av säkerhetsskäl rekommenderar vi starkt att denna produkt monteras av åtminstone två personer.
2. Vissa komponenter har vassa metallkanter. Var försiktig när du hanterar komponenter av metall. Använd handskar, skor och skyddsglasögon vid montering.
3. Lägg alla komponenter på en mjuk matta eller filt för att undvika repor eller skador.
4. Klättra INTE eller stå på taket. Tunga artiklar ska inte lutas mot växthuset.
5. Håll taket och rännan rena från snö, smuts och löv. Om snö samlas upp på taket kan skada produkten.
6. Till skillnad från stål, om lacken är repad kommer detta inte att skada aluminiumet under.
7. När din produkt behöver rengöras, använd ett mildt rengöringsmedel och skölj med kallt rent vatten. Använd inte aceton, slipmedel eller starka rengöringsmedel för att rengöra panelerna.

Verktyg som medföljer

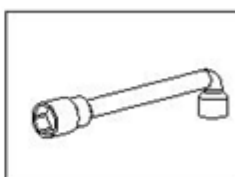
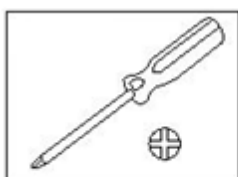

Utrustning som ej medföljer men behövs vid montering

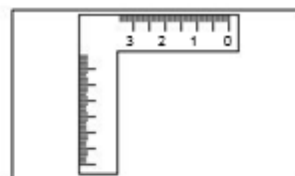
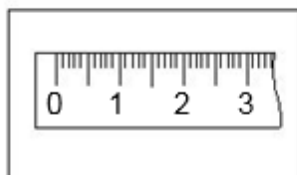

Minst två personer krävs för monteringen



Funktioner

1. Den starka tvådelade takfoten har en integrerad ränna. Stuprör ingår också som standard så att du kan samla regnvatten.

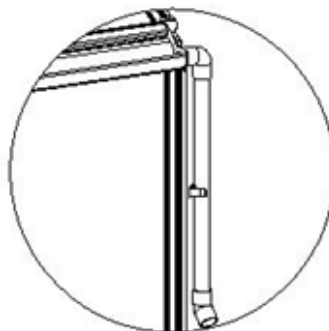

2. Manuella fönsteröppnare ingår som standard med takventilerna. Vid behov finns automatiska fönsteröppnare som ett billigt tillval.

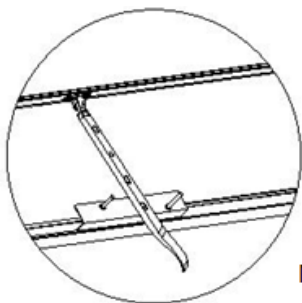

Manuell fönsteröppnare

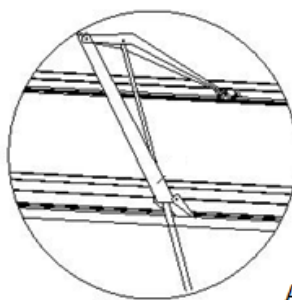

Automatisk fönsteröppnare

3. Ta bort cirka 5 cm film från alla arkanter innan du installerar och ta bort all film omedelbart efter att konstruktionen är klar. Se till att sidan med den vita filmen vetter utåt mot solen. Se nedan.

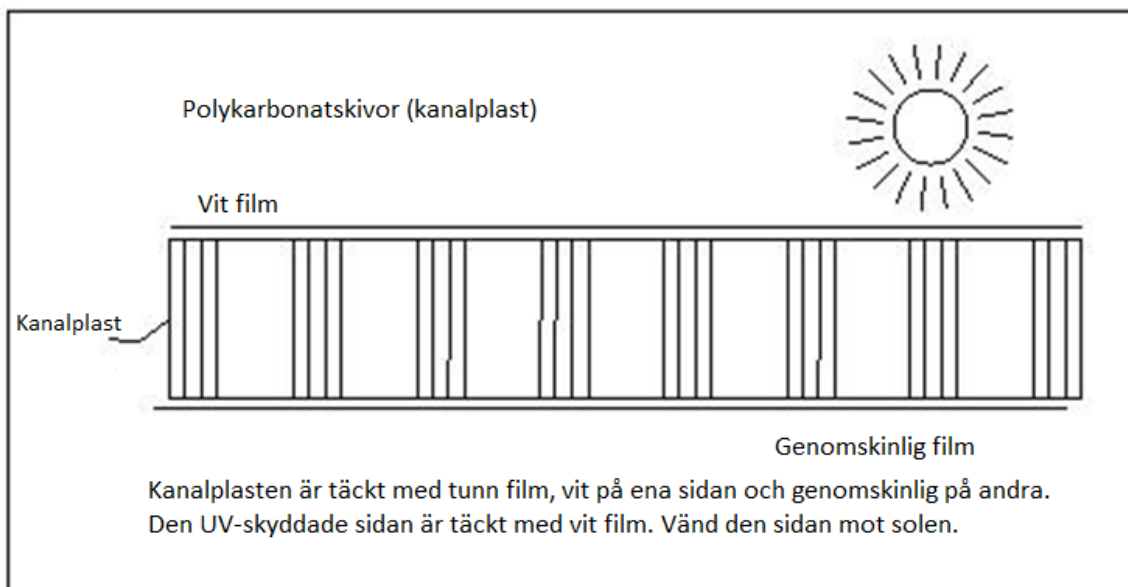





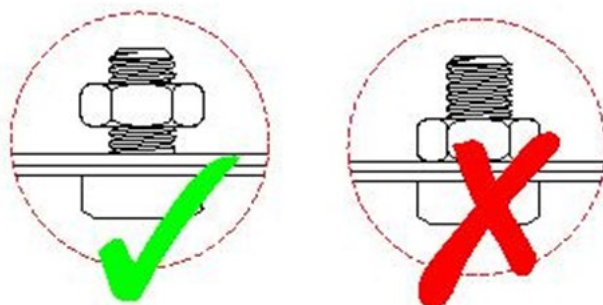















4. Detta kvalitetsväxthus har självgående skruvar för att ge starka skarvar. Som namnet antyder knackar skruvarna på sin egen gänga. Att köra i självgående skruvar kräver mer kraft än konventionella skruvar. En elektrisk skruvdragare rekommenderas därför.



















5. Dra inte åt bultar/muttrar/skruvar innan monteringen är slut! Om inte annat anges, dra inte åt bultarna/muttrarna/skruvarna förrän växthuset är färdigmonterat!















Komponentlista







Del	#	Antal
	L01A	4
	L01B	4
	L02A	4
	L02B	4
	L02C	2
	L04A	4
	L04B	11
	L05A	8
	L05B	2
	L06C	1
	L07C	2
	L09C	2
	L10B	2
	L10C	2
	L14B	1
	L25	4
	L26	6

Del	#	Antal
	L15	1
	L16	2
	L17	1
	L18	2







Del	#	Antal
	J55	2
	J56R	2
	J56L	2
	J90R	1
	J90L	1
	J91	2
	J94	4
	J93	4
	J92	4
	D17	2
	A03	2
	S01 M6X12	112
	S02 M6X20	20
	M01 M6	132
	Z01 Ø4X25	16
	Z02 Ø4X16D	22
	Z04 Ø4X8	4
	Z08 M4.2X16	4

Del	#	Antal
	L11A	2
	L12A	2
	L19	4
	L20	2
	L21	2
	A01	2

Del	#	Antal
	D1	2
	D2	2
	D70	4
	S01 M6X12	16
	M01 M6	16
	Z08 M4.2X16	28









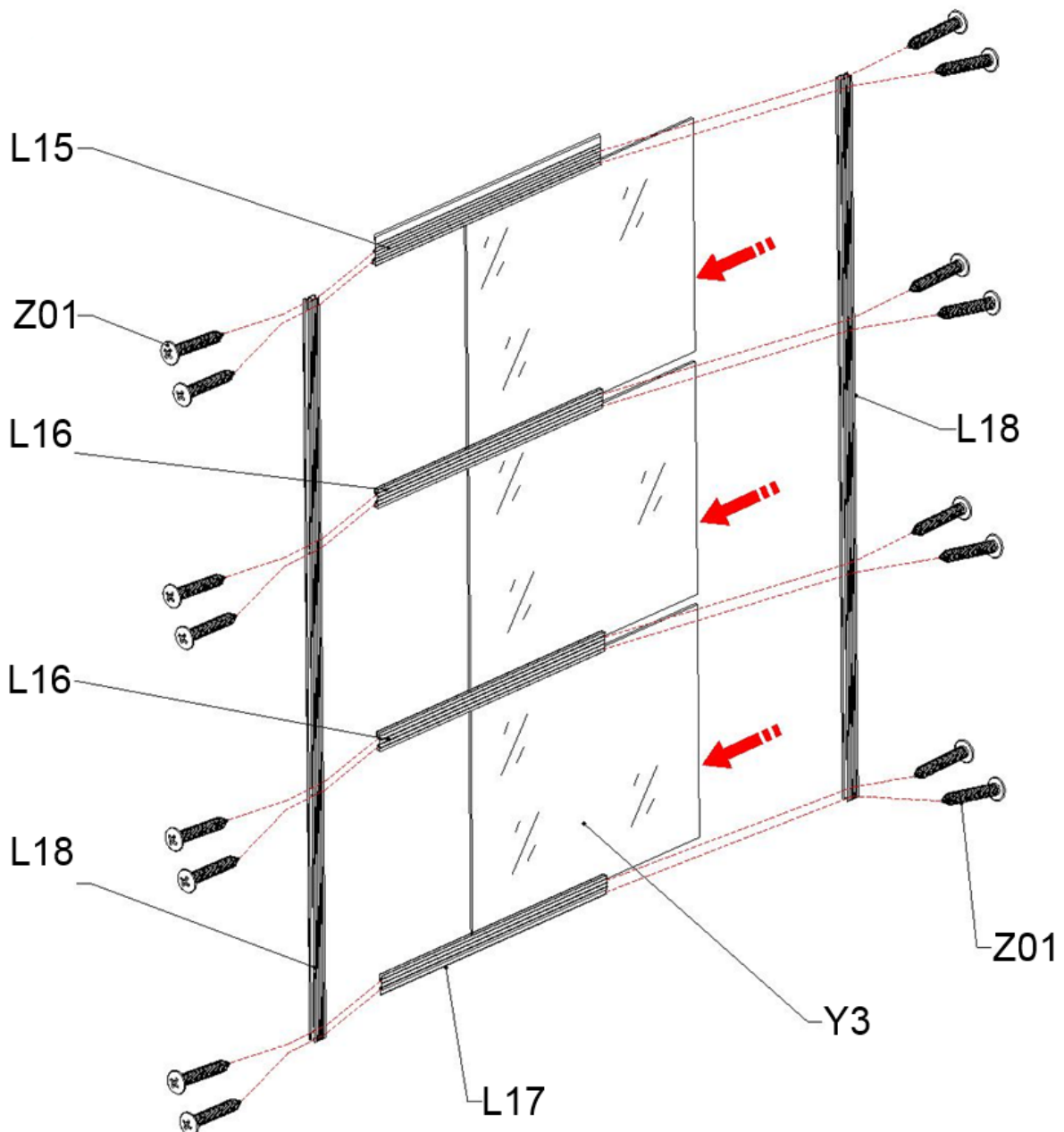
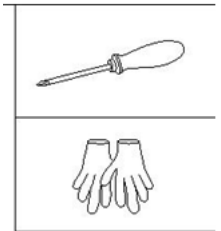

Del	#	Antal
	Y1	18
	Y2	4
	Y3	3
	Y4	4
	Y5	4
	Y6	2

Montering

Del	#	Antal
	L15	1
	L16	2
	L17	1
	L18	2
	Z01 Ø4X25	16
	Y3	3

1. Fixera L15, L16x2 och L17 till L18 med 8 x Z01
2. Skjut in panelerna i position
3. Fixera ytterligare en L18 med 8 x Z01



Del	#	Antal
	L11A	1
	L12A	1
	L19	2
	L20	1
	L21	1
	A01	1
	Z02 Ø4X16D	6
	Z04 Ø4X8	2
	Z08 M4 2X16	2
	S01 M6X12	2
	Y6	1

Montera fönsterx2

Fäst A01 på L21 med Z04x2

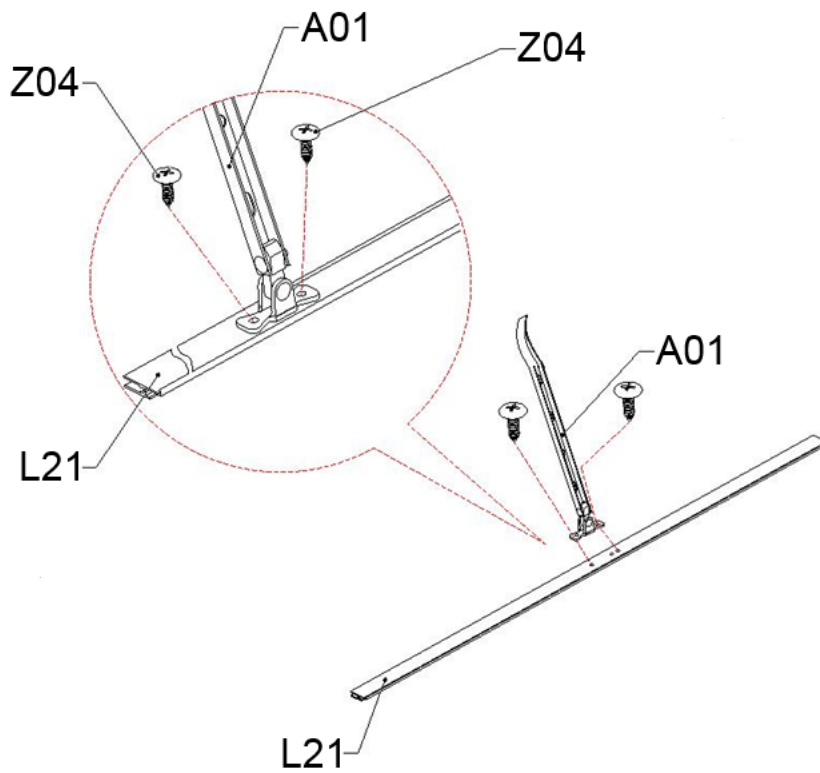



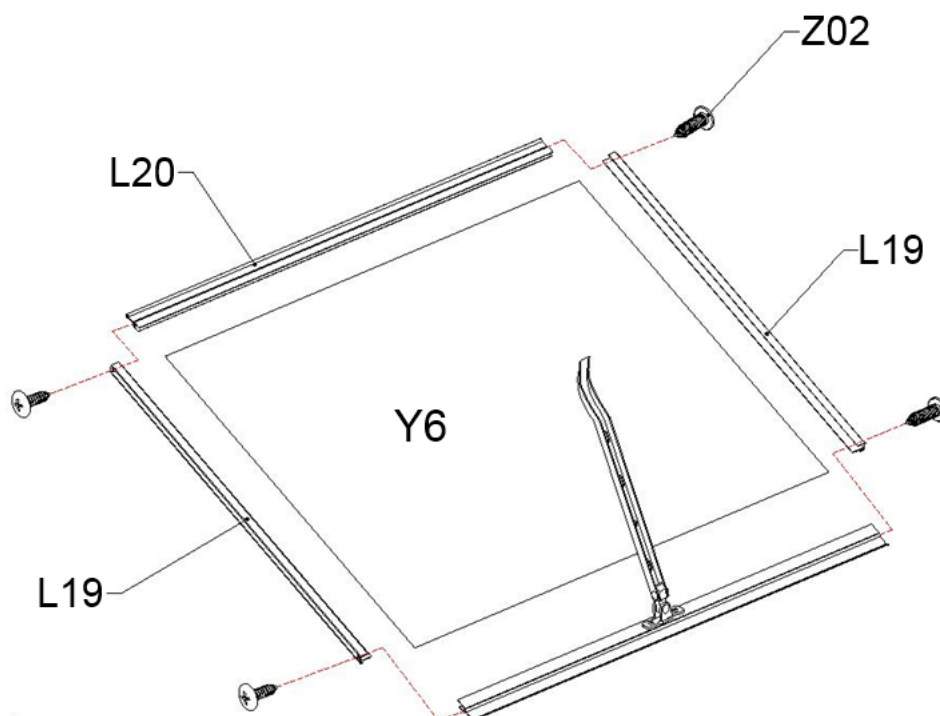

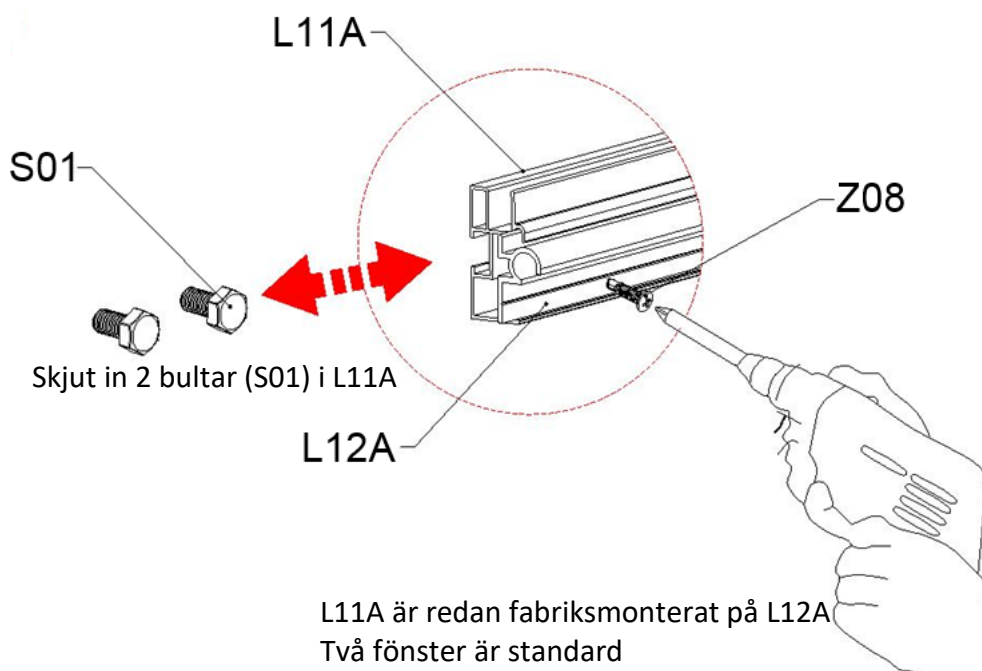
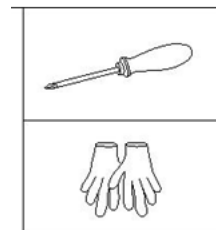
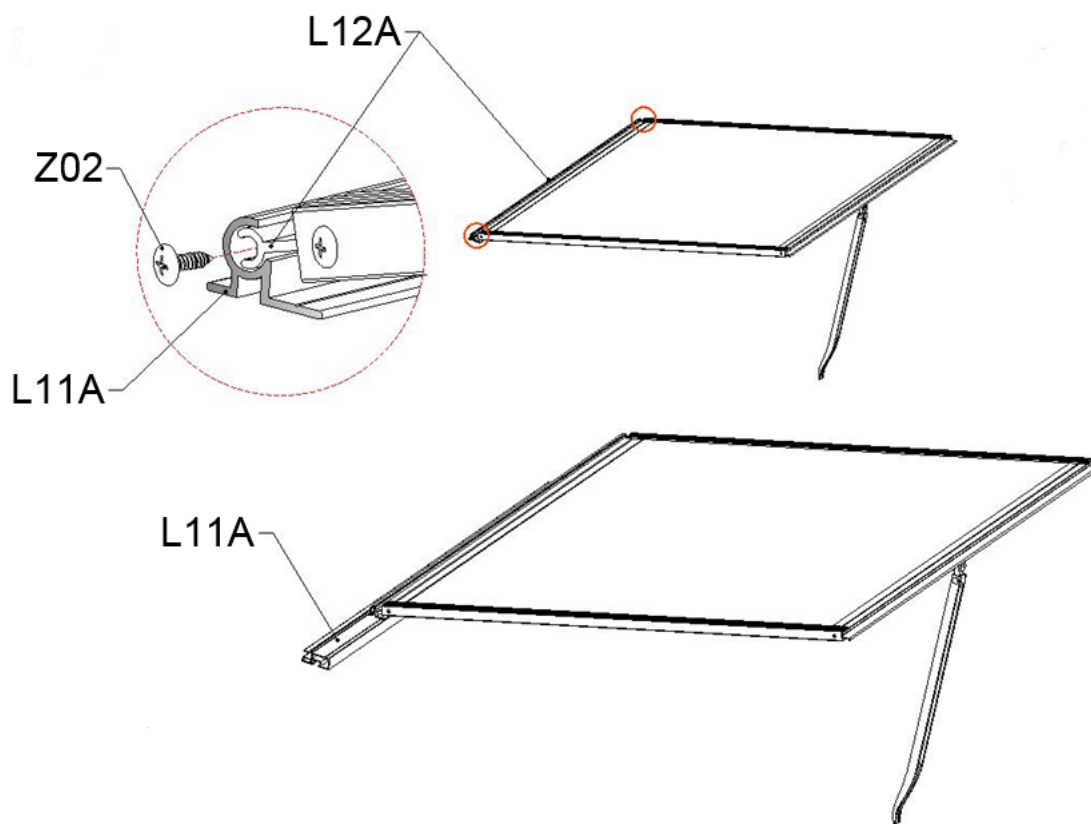

1. Fixera L21 och L20 till L19 med 2 x Z02
2. Skjut panelerna på plats
3. Fixera ytterligare en L19 med 2 x Z02



1. Skjut in L11A i L12A
2. Fäst L11A och L12A med 2 x Z02



Del	#	Antal
	D1	2
	D2	2
	D70	4
	S01 M6X12	16
	M01 M6	16
	Z08 M4.2X16	28

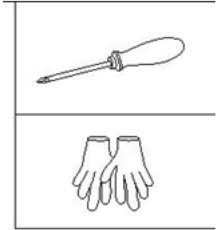
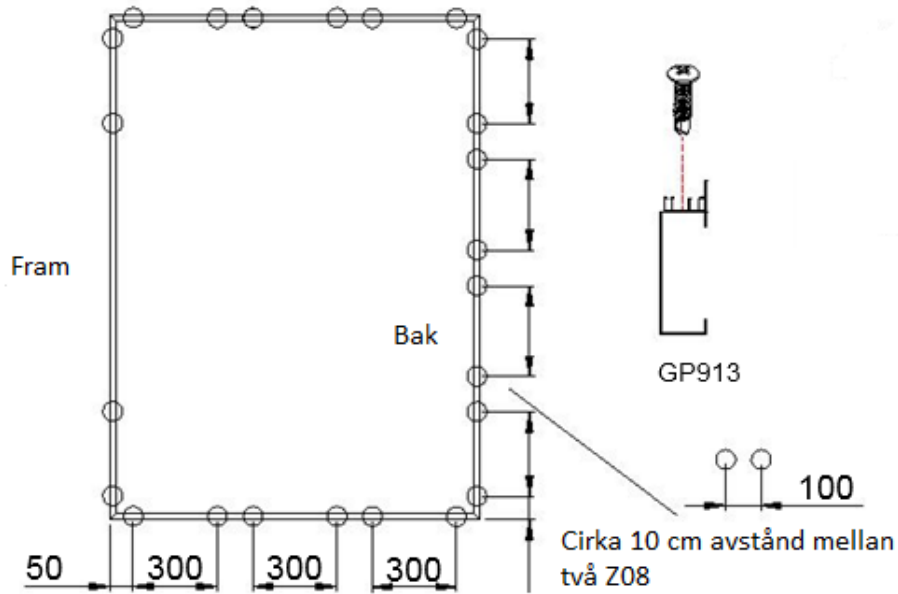

$a=b$

Montera basen innan du monterar växthuset.
Så här monterar du basen.

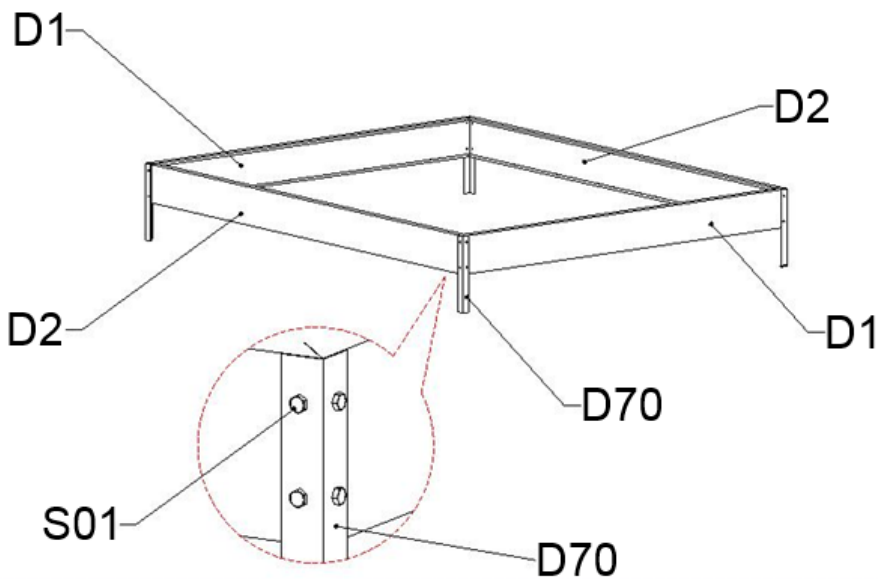
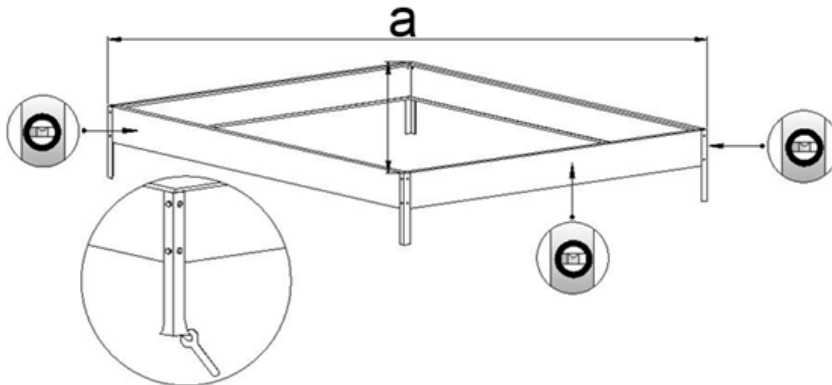

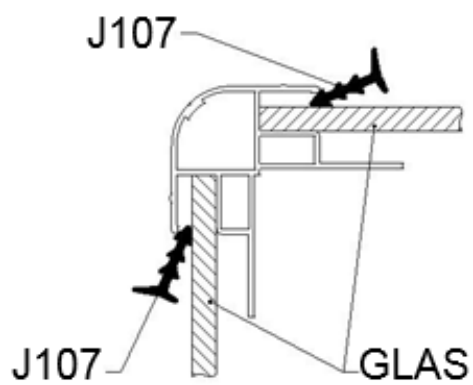
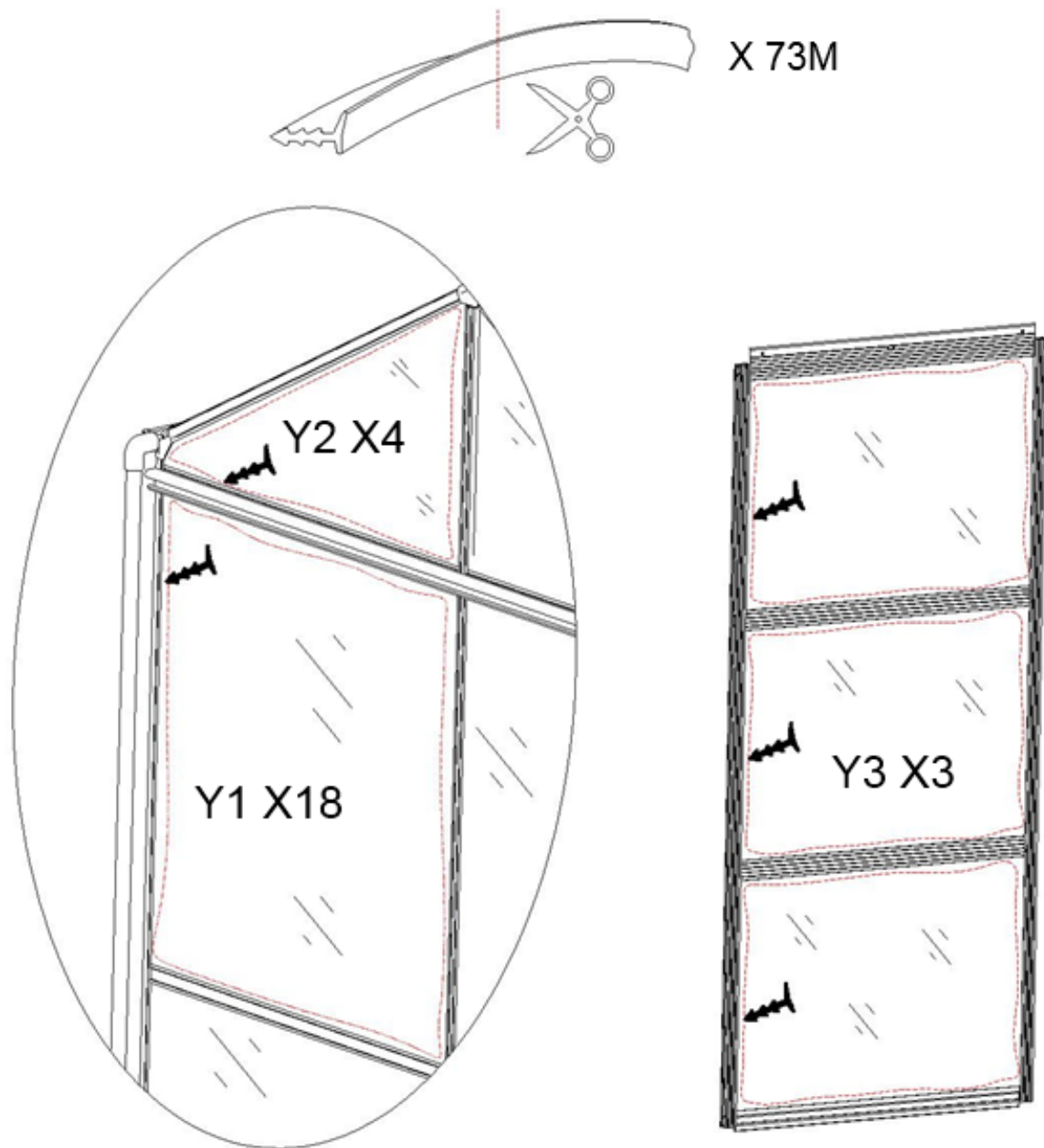





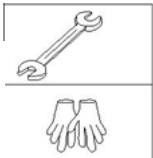

Obs:

Om din modell har fönster av glas, försegla det med medföljande gummi (J107) efter hela monteringen är klar.

Gummi tillhandahålls inte om du väljer polykarbonatplåt som fönsterpanel.



Del	#	Antal
	L01A	4
	L10B	2
	L10C	2
	Z08 M4.2X16	28
	S01 M6X12	8
	M01 M6	8

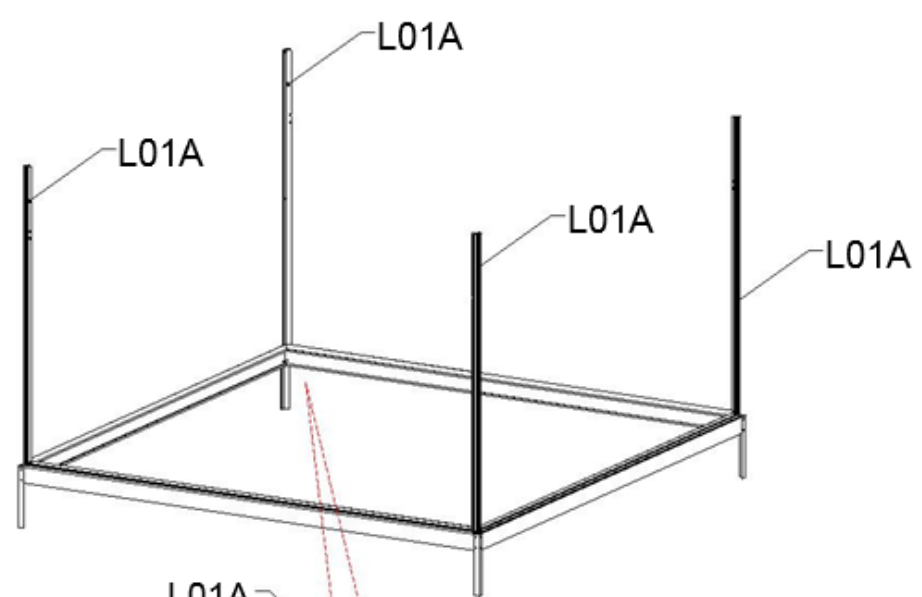



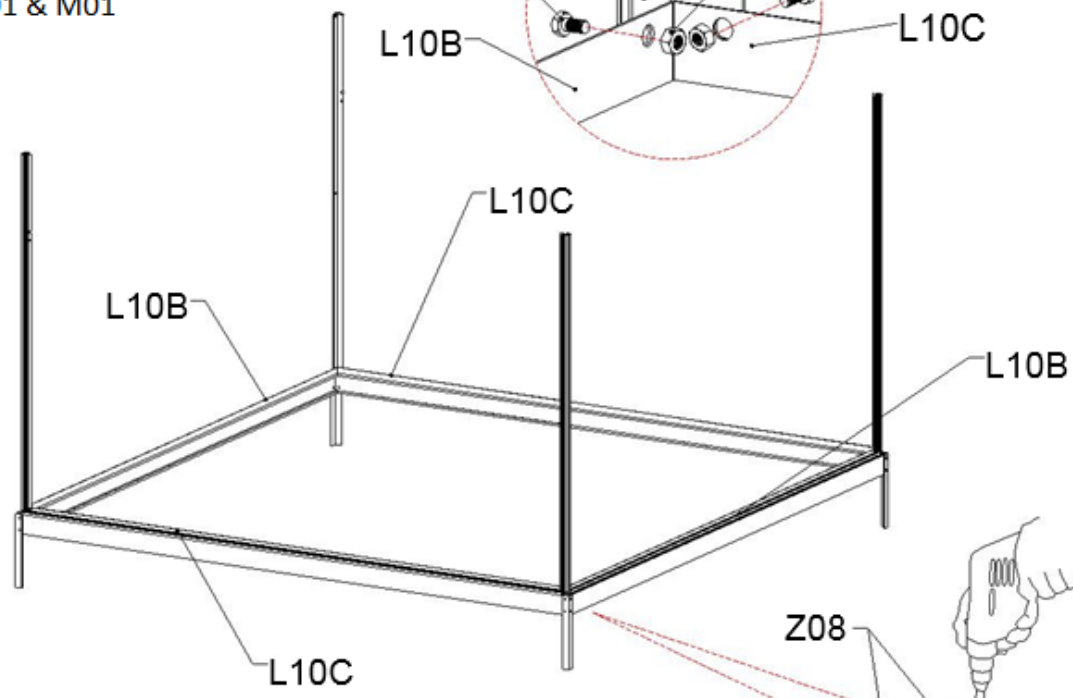
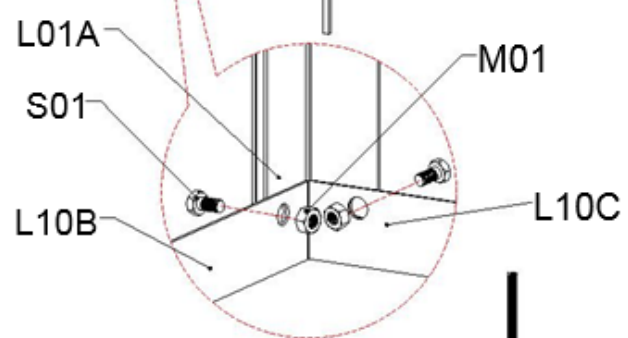

1. Fäst profilerna (4 x L01A) på basen (L10B & L10C), med S01 & M01

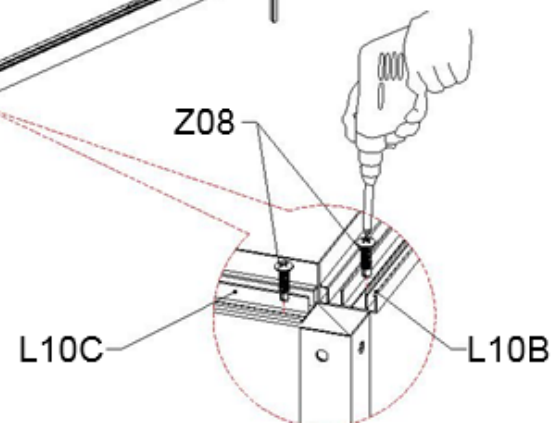

2. Fäst profilerna på basen med Z08, med hjälp av en skruvdragare.



Del	#	Antal
	L07C	2
	L05B	2
	L02A	4
	S01 M8X12	20
	M01 M8	20

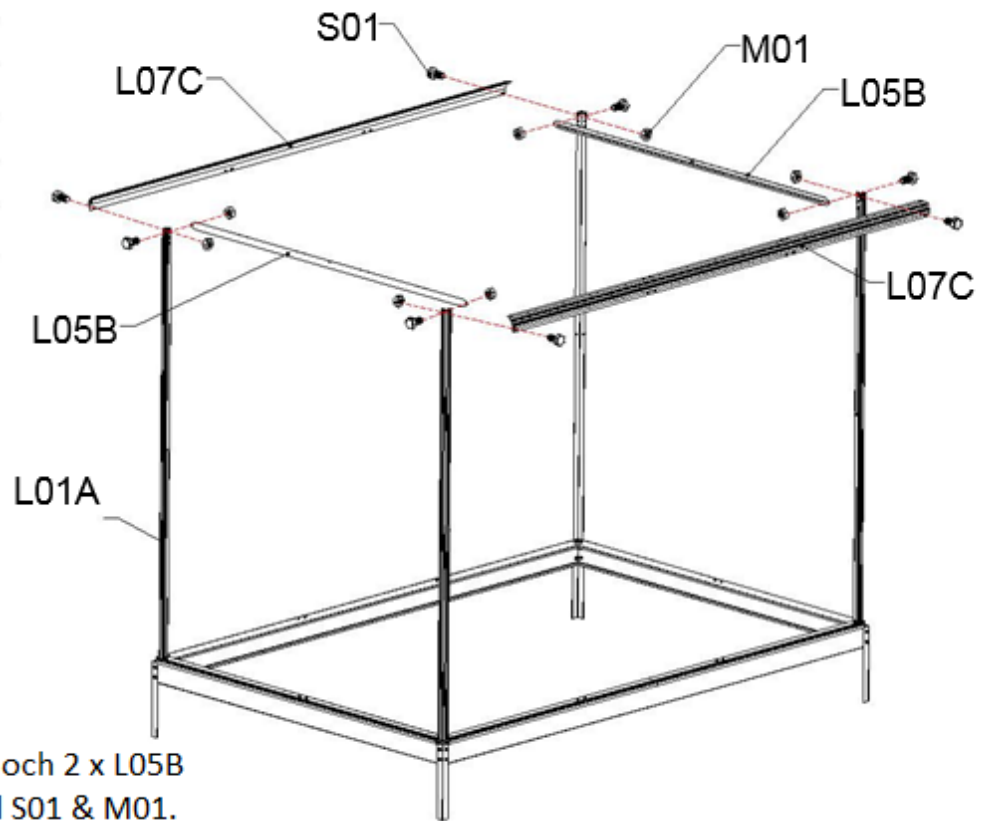

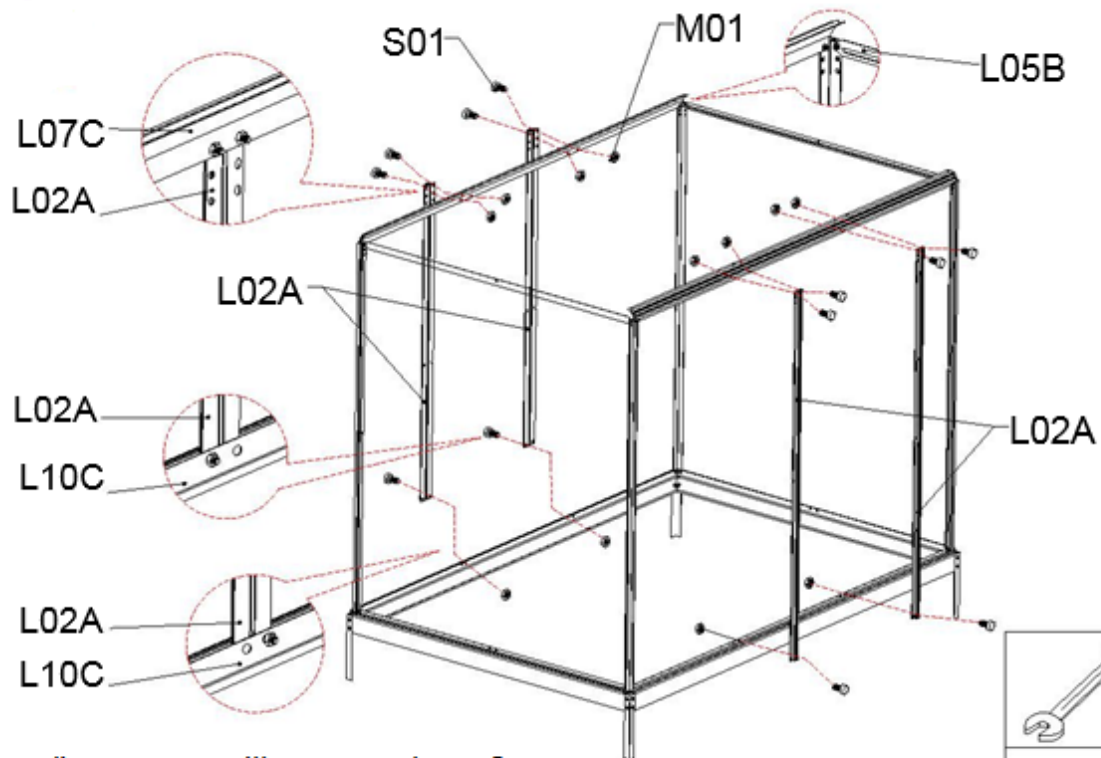

1. Fäst 2 x L07C och 2 x L05B till L01A, med S01 & M01.



2. Fäst 4 x L02A till L07C med S01 & M01



Del	#	Antal
	L05A	4
	S01 M8X12	8
	M01 M8	8

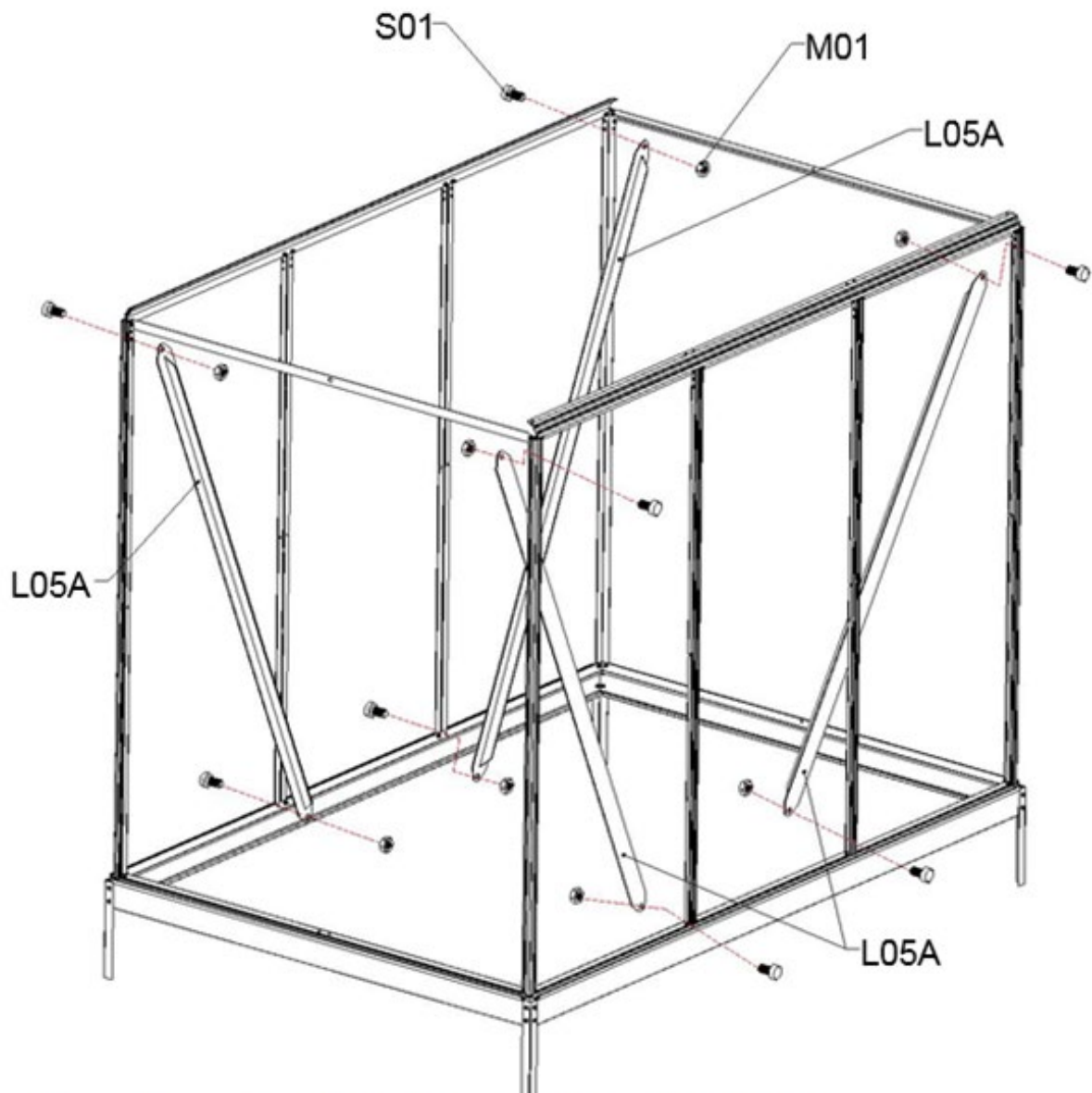
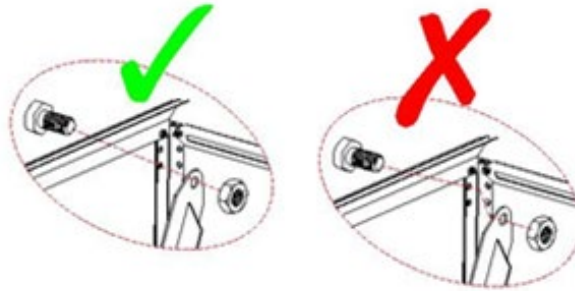

Fixera stöden 4 x L05A till L01A och L02A med S01 & M01

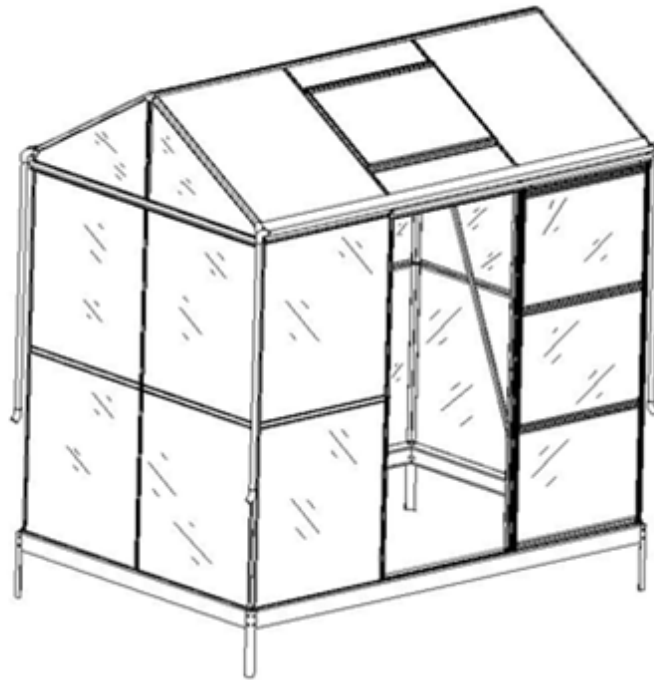



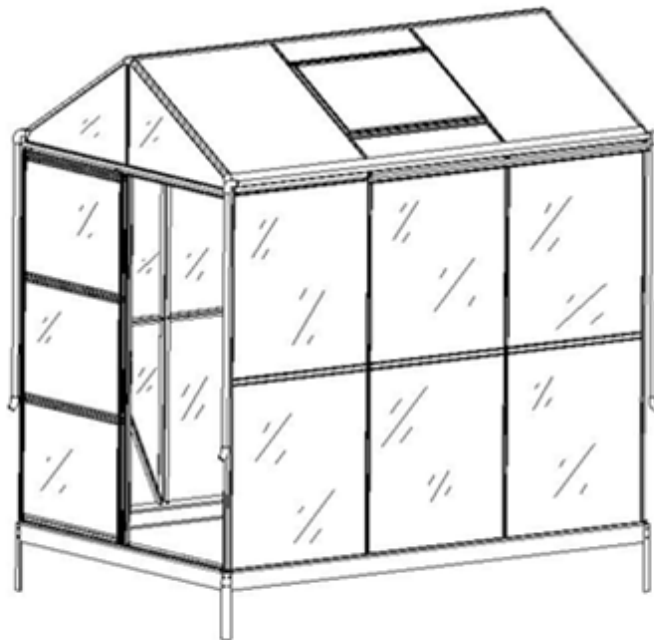

För montering av dörr på långsida, läs från nästa sida.



För montering av dörr på kortsida, hoppa till sida 32.

Montering med dörr på långsida

Del	#	Antal
	L05A	4
	L02C	2
	S01 M8X12	10
	M01 M6	10

1. Skjut in 2 x S01 i 2 x L02C -bultkanal.

2. Fäst 2 x L02C till L10B, L10C och L05B med S01 & M01

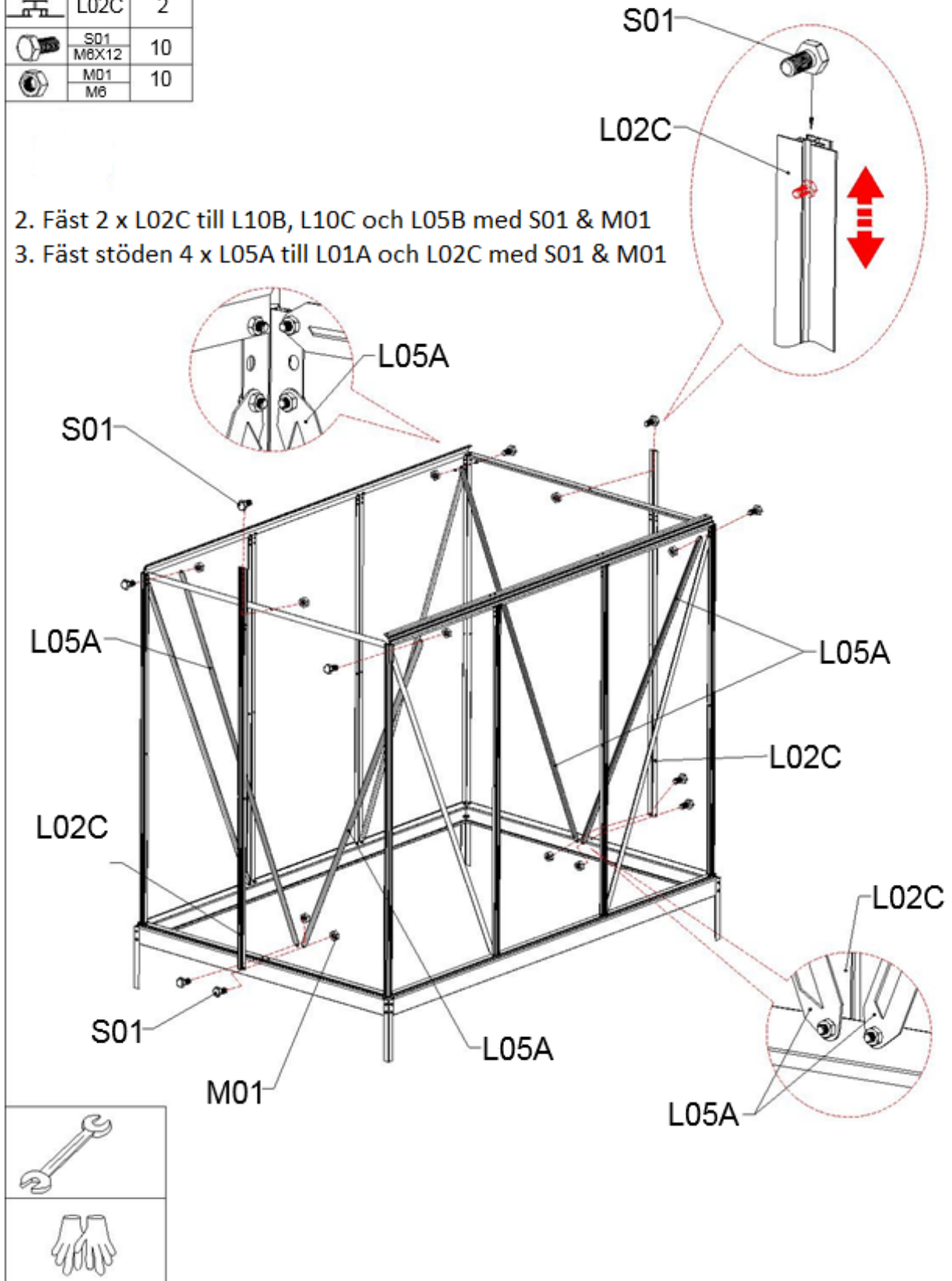

3. Fäst stöden 4 x L05A till L01A och L02C med S01 & M01

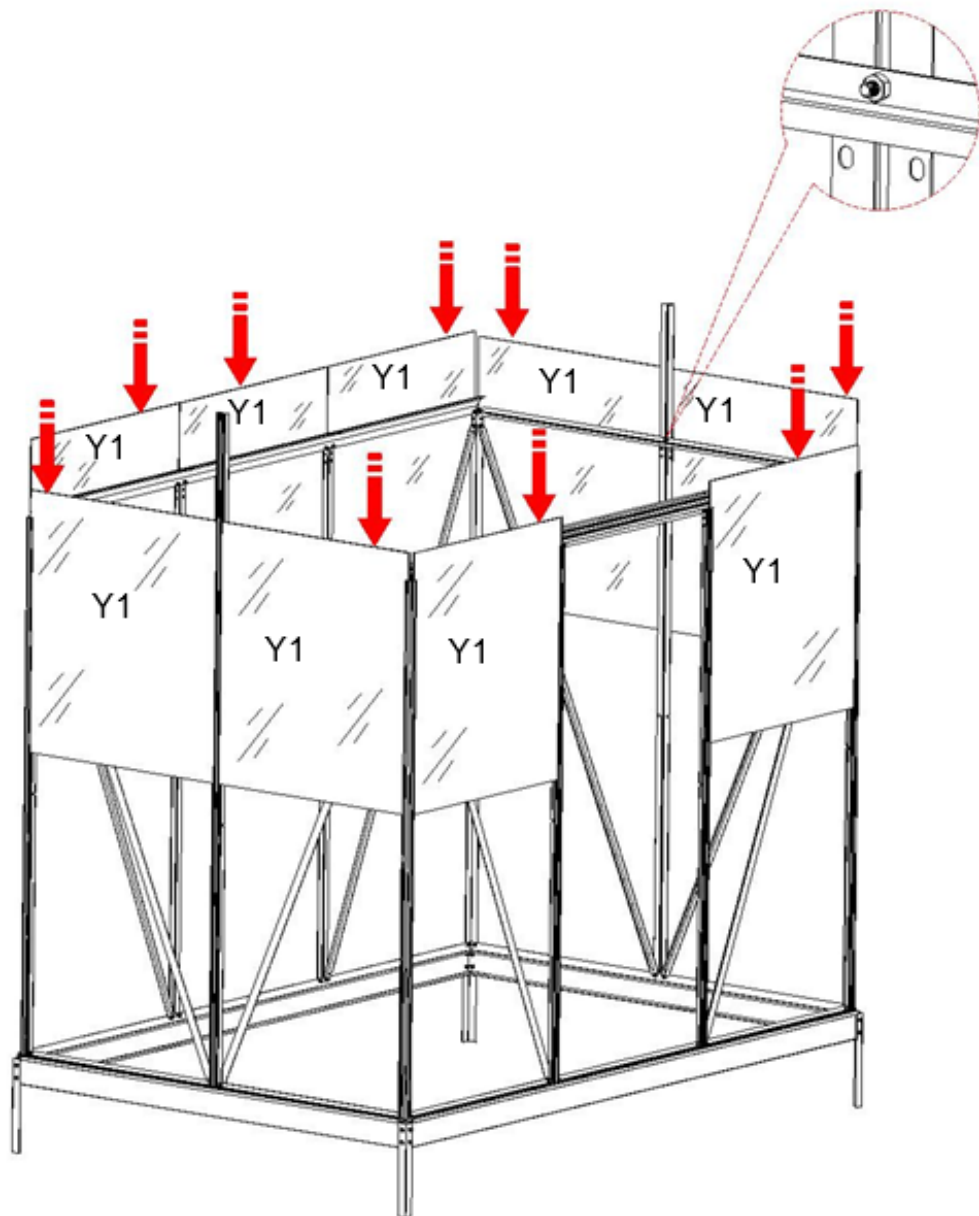

Del	#	Antal
	Y1	9

Skjut glasrutorna på plats



Del	#	Antal
	L04B	11
	S01	22
	M8X12	

Skjut in 2 x S01 i L04B -bultkanalen.

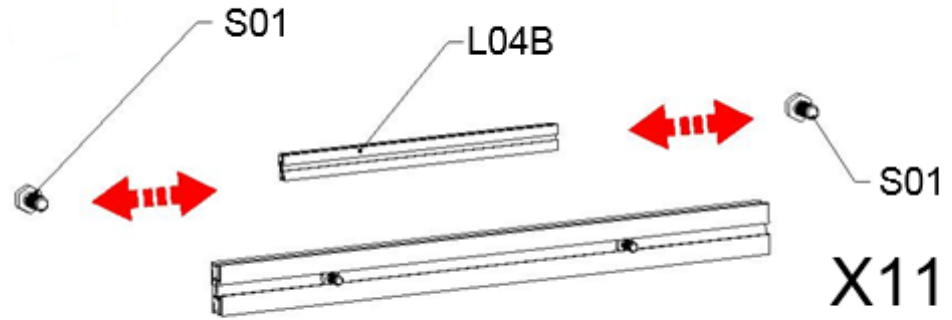

Fäst stöden L04B (9st) enligt ovan, med S01 & M01.

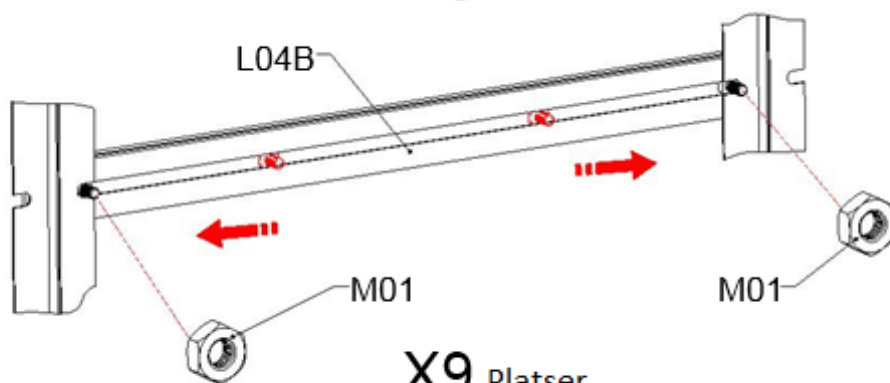
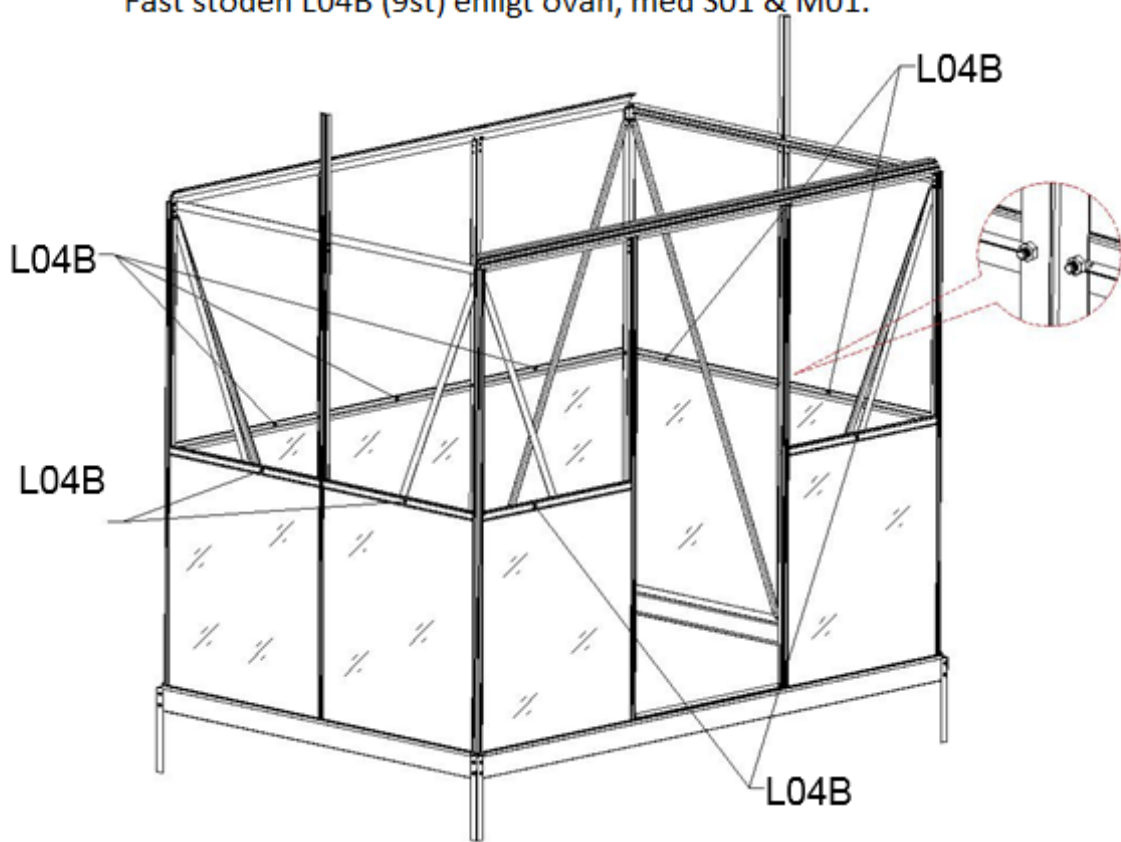



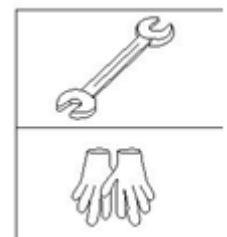

Flytta 2 bultar (S01) och använd 2 x M01 för att fästa L04B

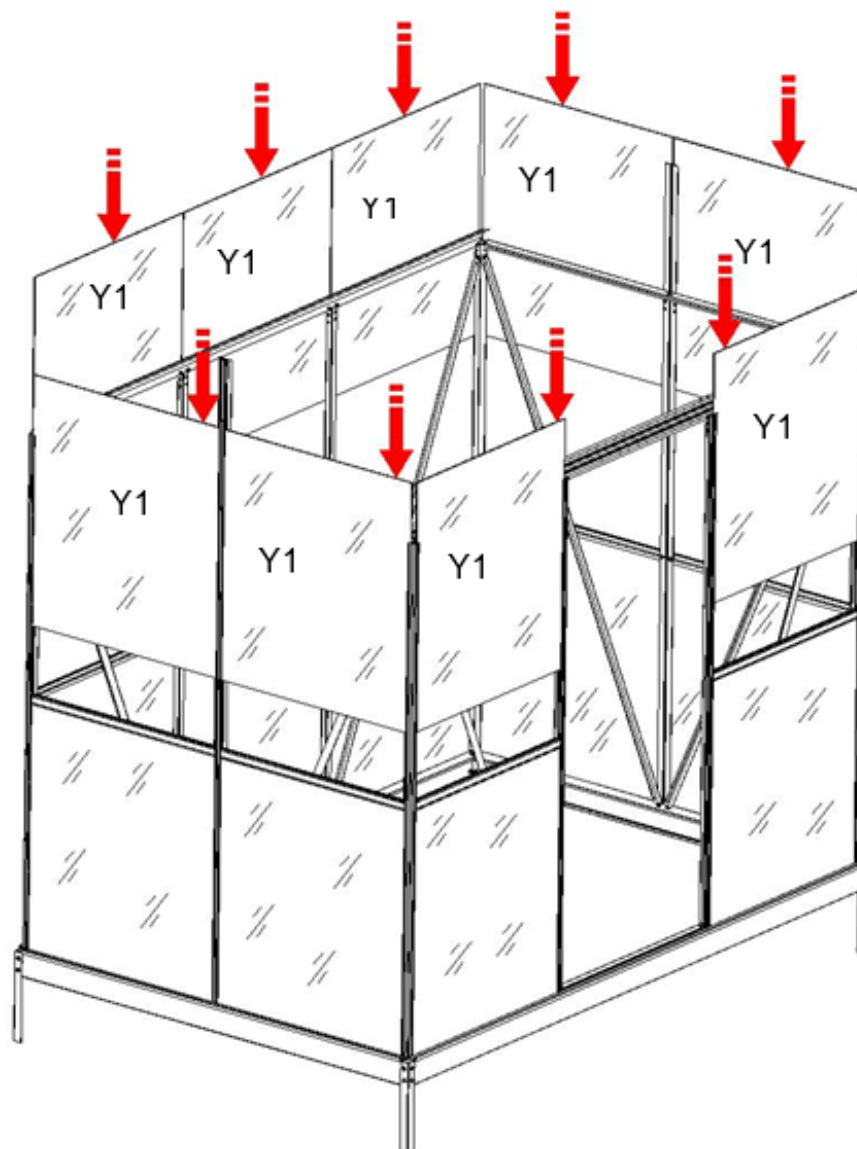

Del	#	Antal
	Y1	9

Skjut glasrutorna på plats



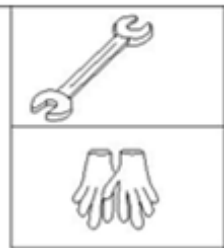

Del	#	Antal
	L04A	4
	S02	8
	M8X20	
	M01	8
	M8	



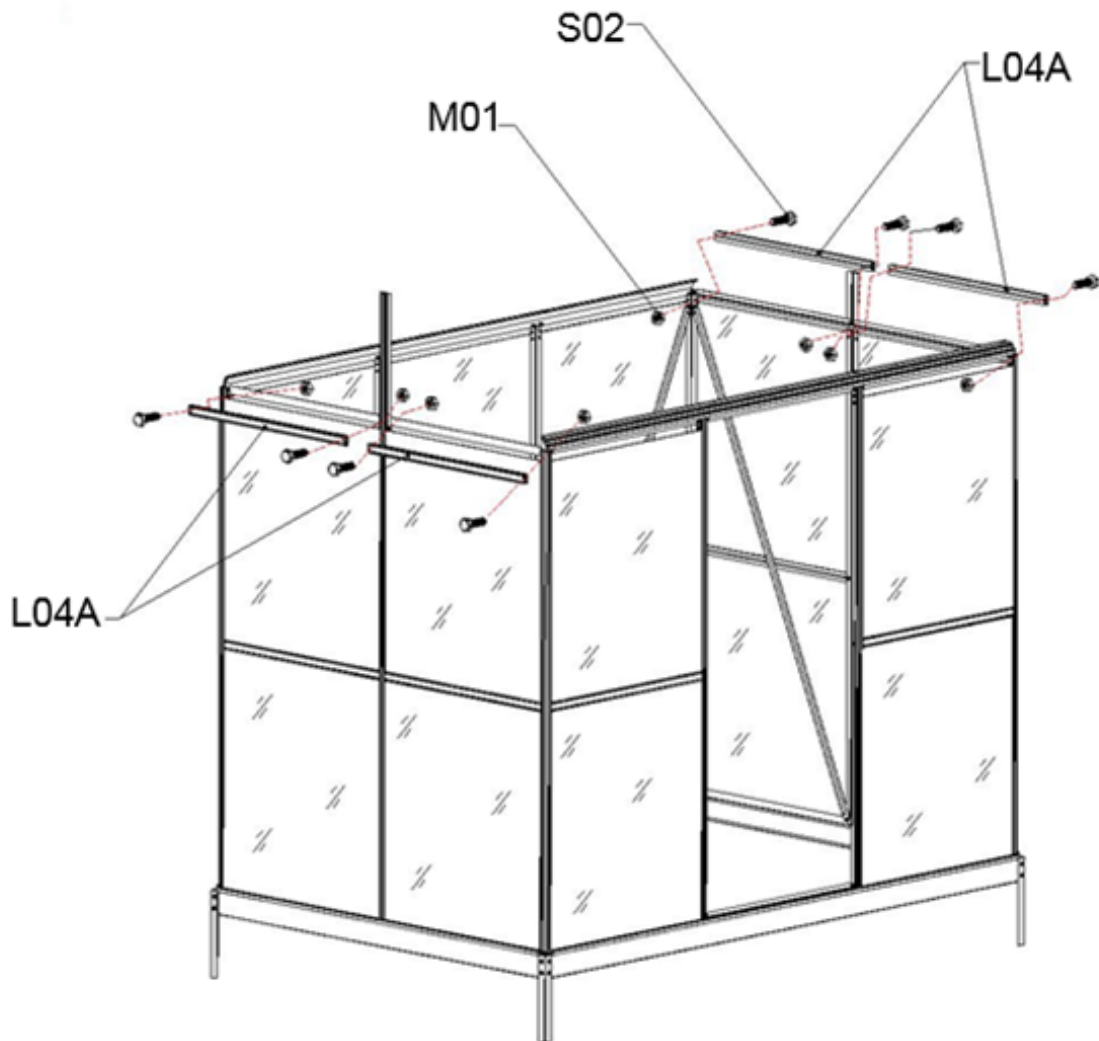



Fäst stöden L04A (4st) enligt nedan med S02 & M01.

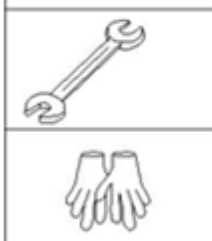
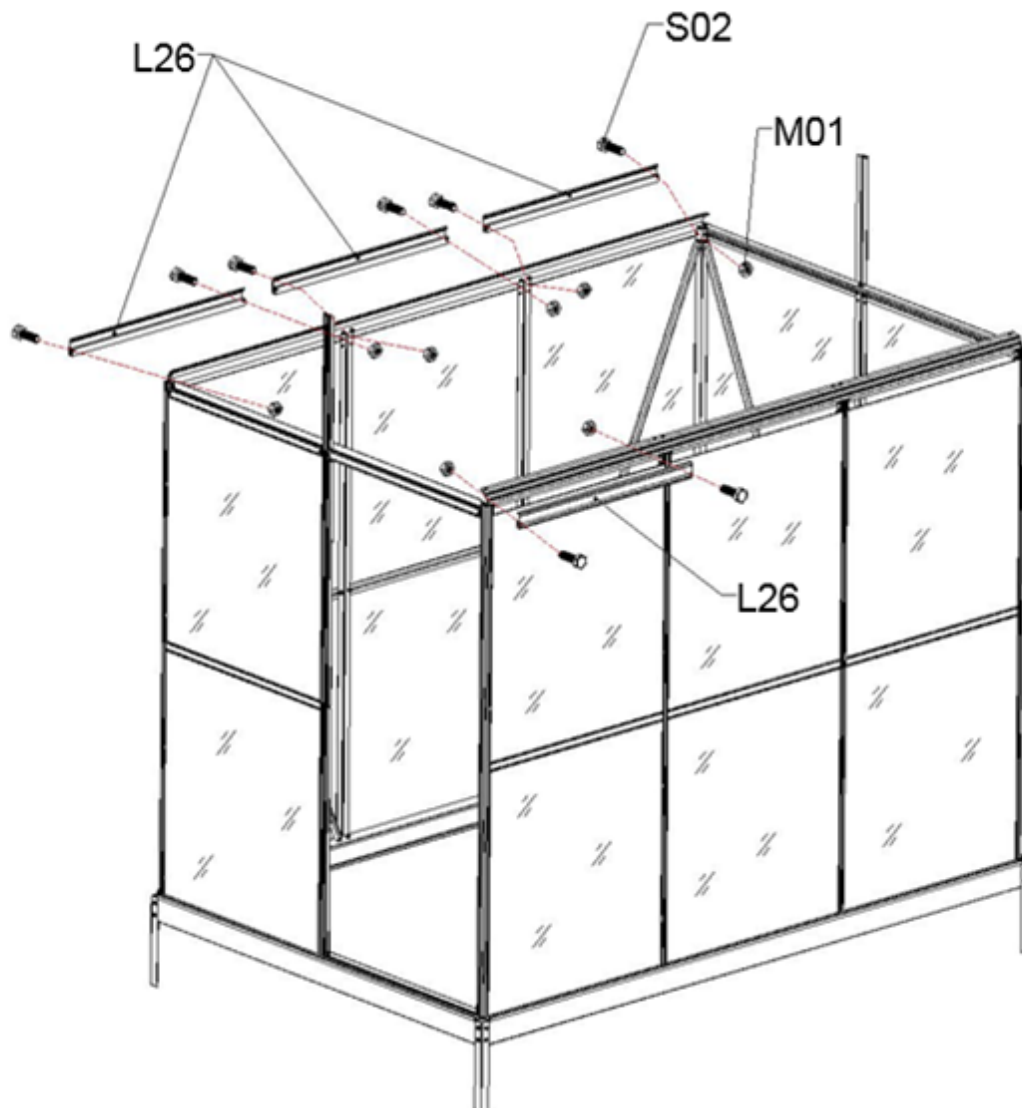

Del	#	Antal
	L26	4
	S02 M8X20	8
	M01 M8	8

Fäst stöden L26 (4st) enligt nedan med S02 & M01.



Del	#	Antal
	L26	2
	L14B	1
	S02	4
	M01	4
	M6	4

1. Fäst stöden L26 (2st) enligt ovan med S02 och M01, men dra inte åt bultarna/muttrarna.

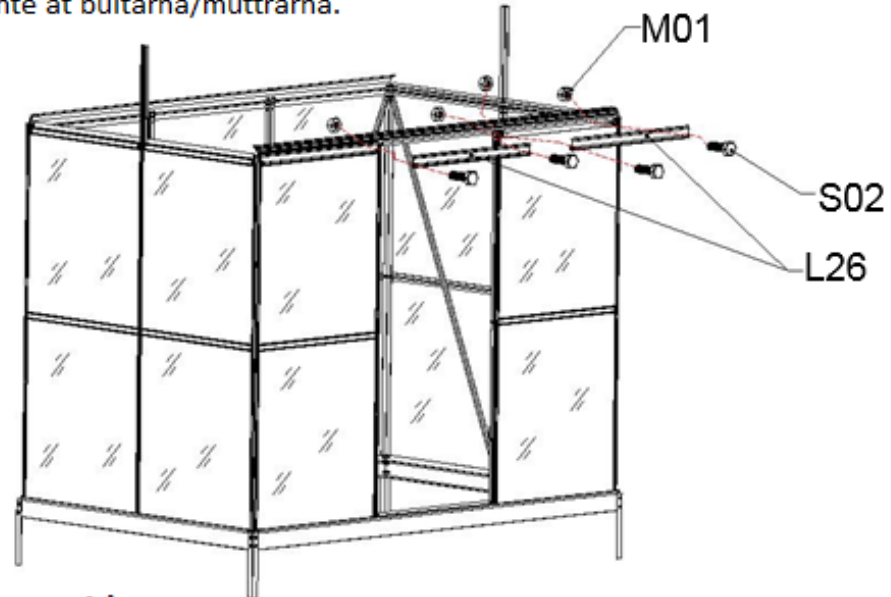

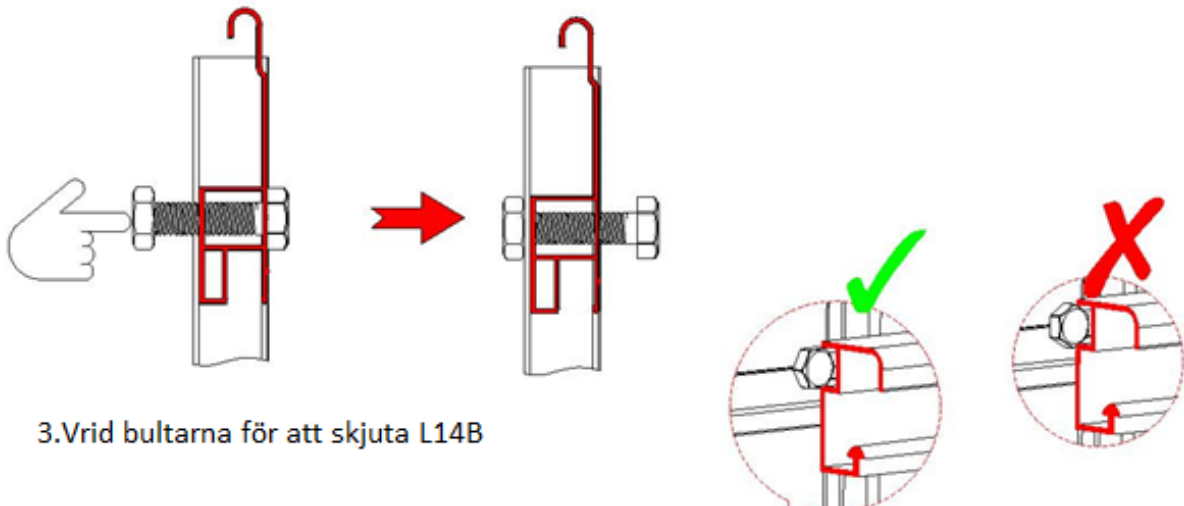

2. Tryck muttrarna inifrån

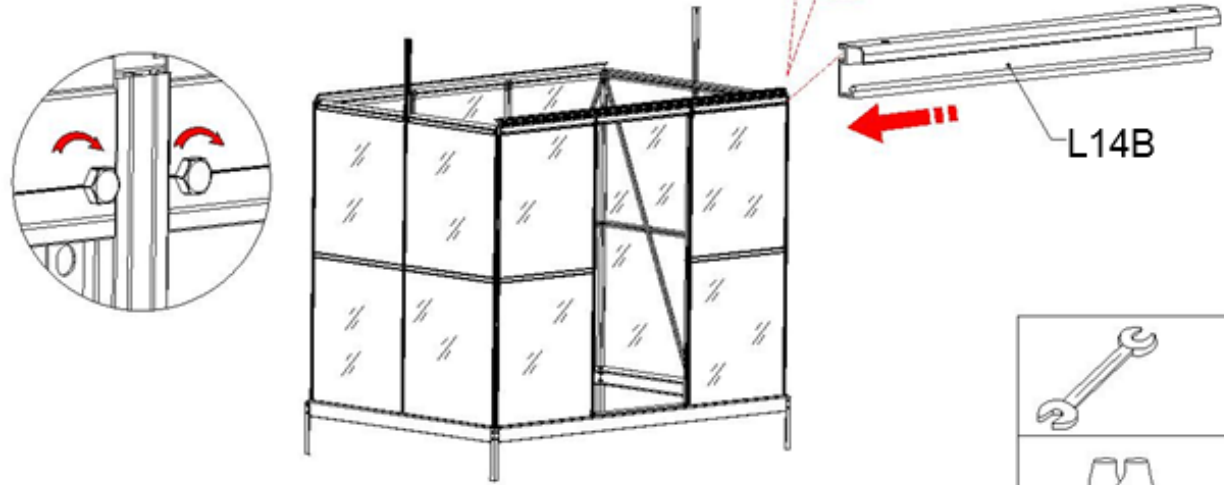

3. Vrid bultarna för att skjuta L14B



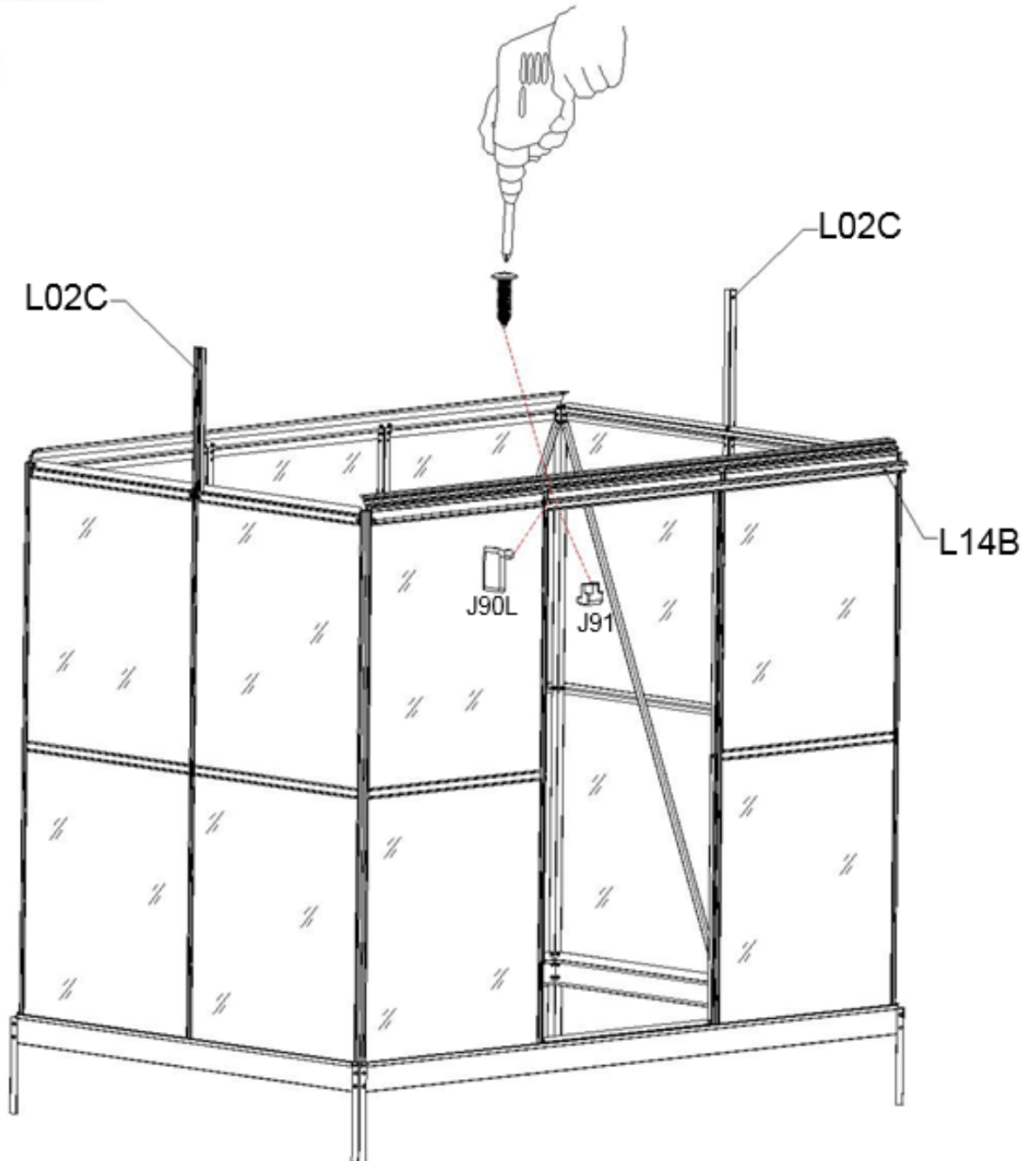

4. Dra åt bultarna/muttrarna

Del	#	Antal
	J90L	1
	J91	1
	Z02 Ø4X18D	1





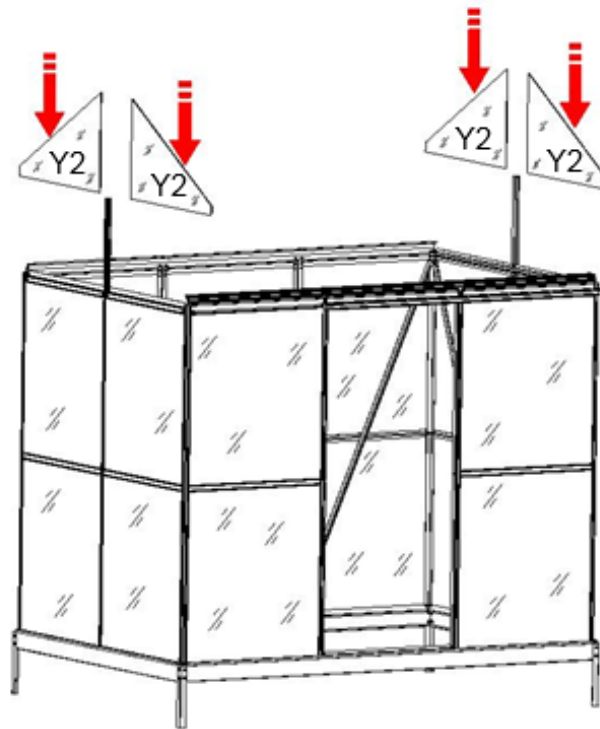

1. Fäst J91 i L14B med Z02
2. Fäst J90L i L14B

Del	#	Antal
	L01B	4
	Y2	4
	S01 M8x12	6

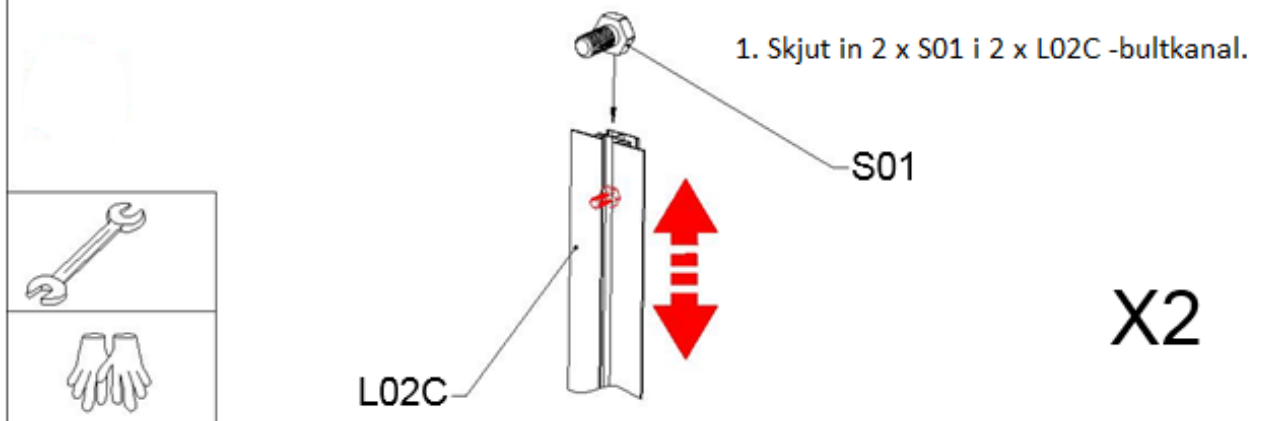
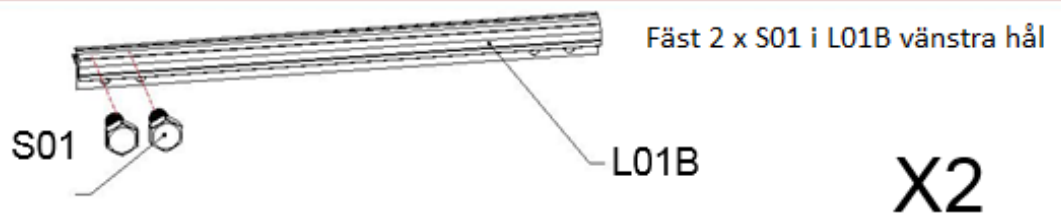
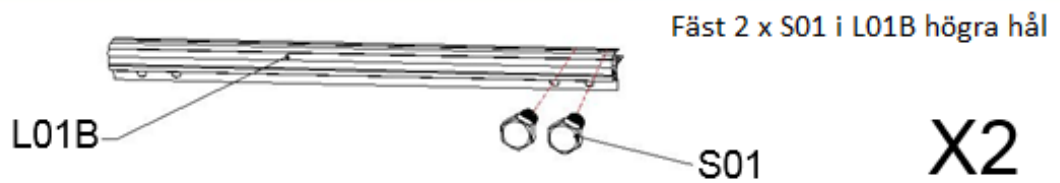





Skjut glasrutorna på plats

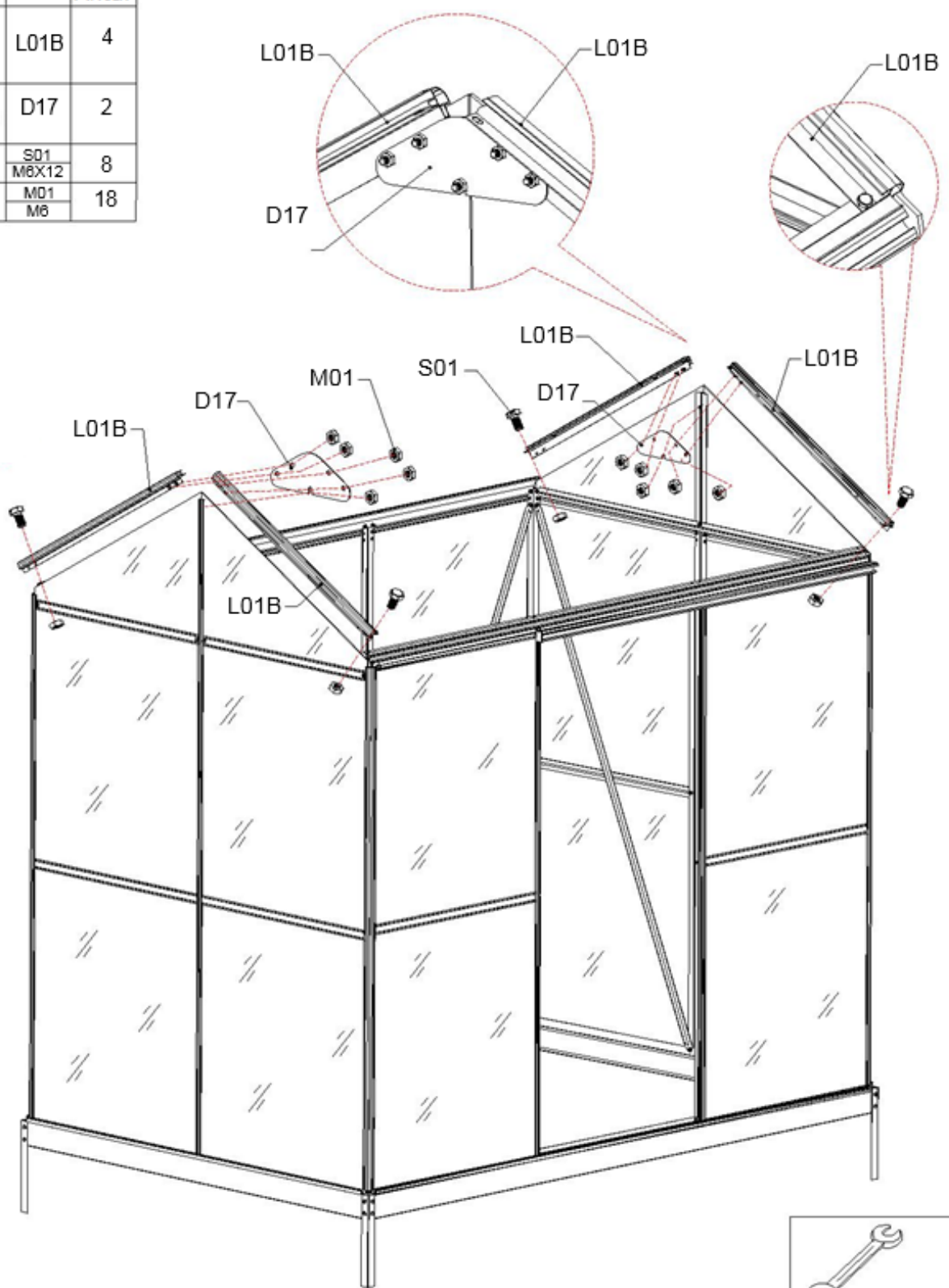



Del	#	Antal
	L01B	4
	D17	2
	S01 M6X12	8
	M01 M6	18



3. Fäst L01B med plattan D17 med S01 och M01 förinstallerad ovan.

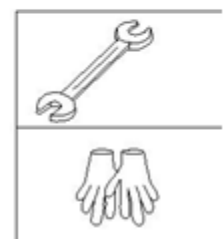
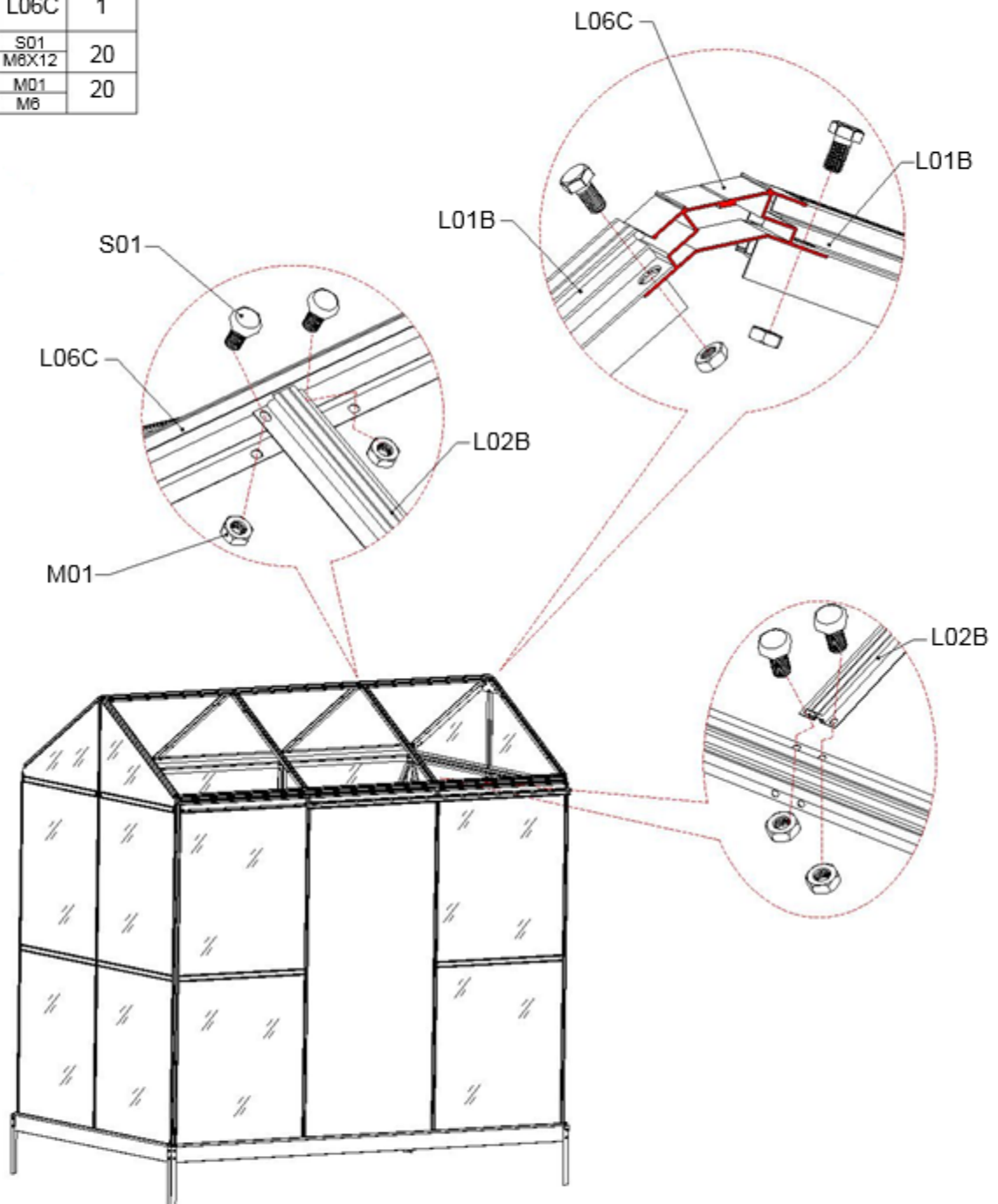



Del	#	Antal
	L02B	4
	L06C	1
	S01 M6X12	20
	M01 M6	20

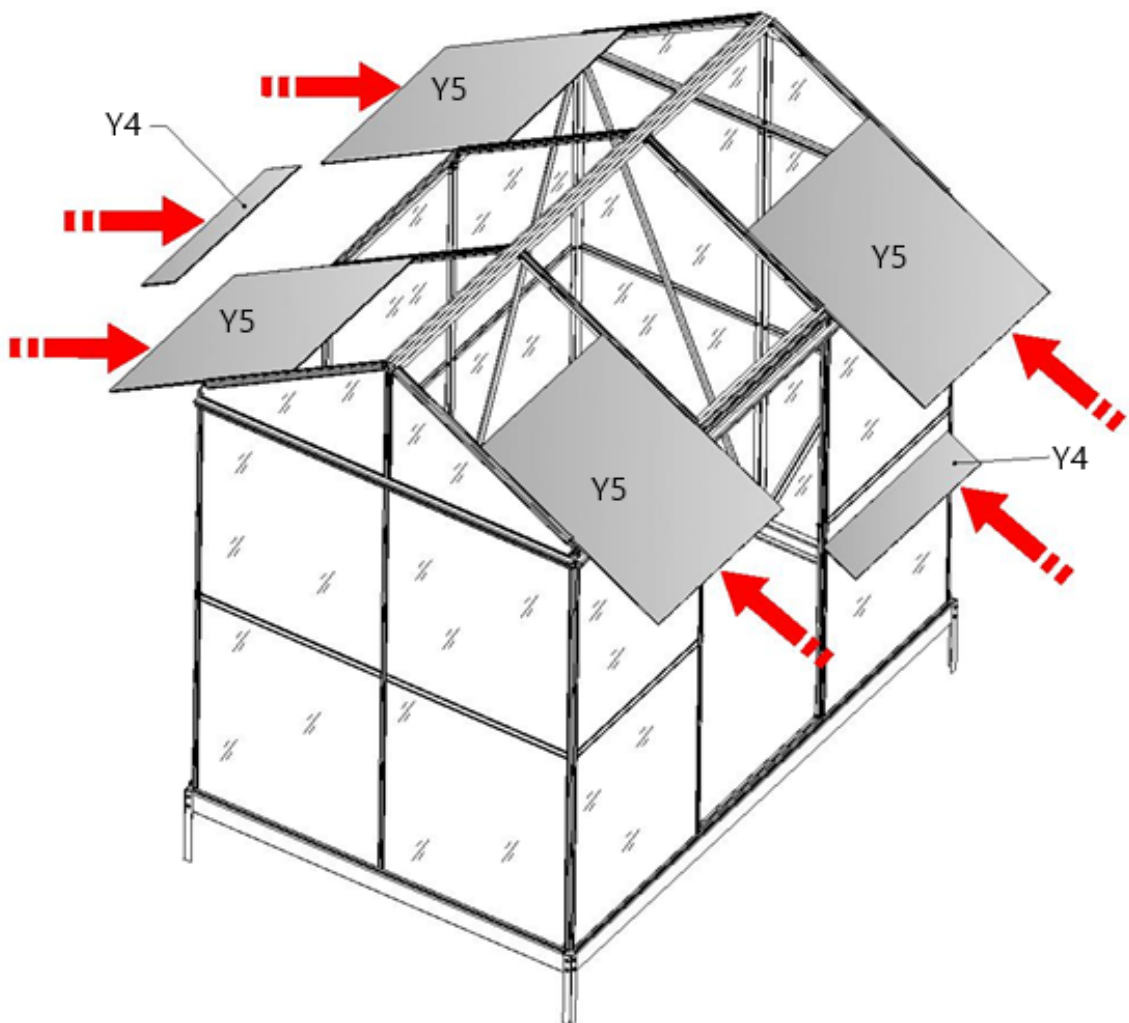

Del	#	Antal
	Y4	4
	Y5	4

Skjut polykarbonatpanelerna (kanalplast) på plats



Del	#	Antal
	L04B	2
	A03	2
	S01 M6X12	4
	M01 M6	8

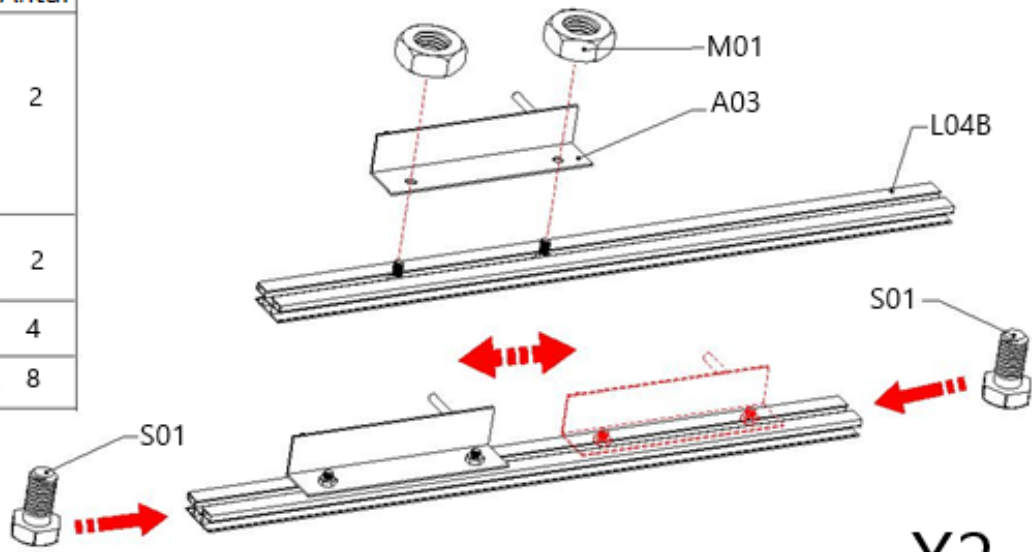

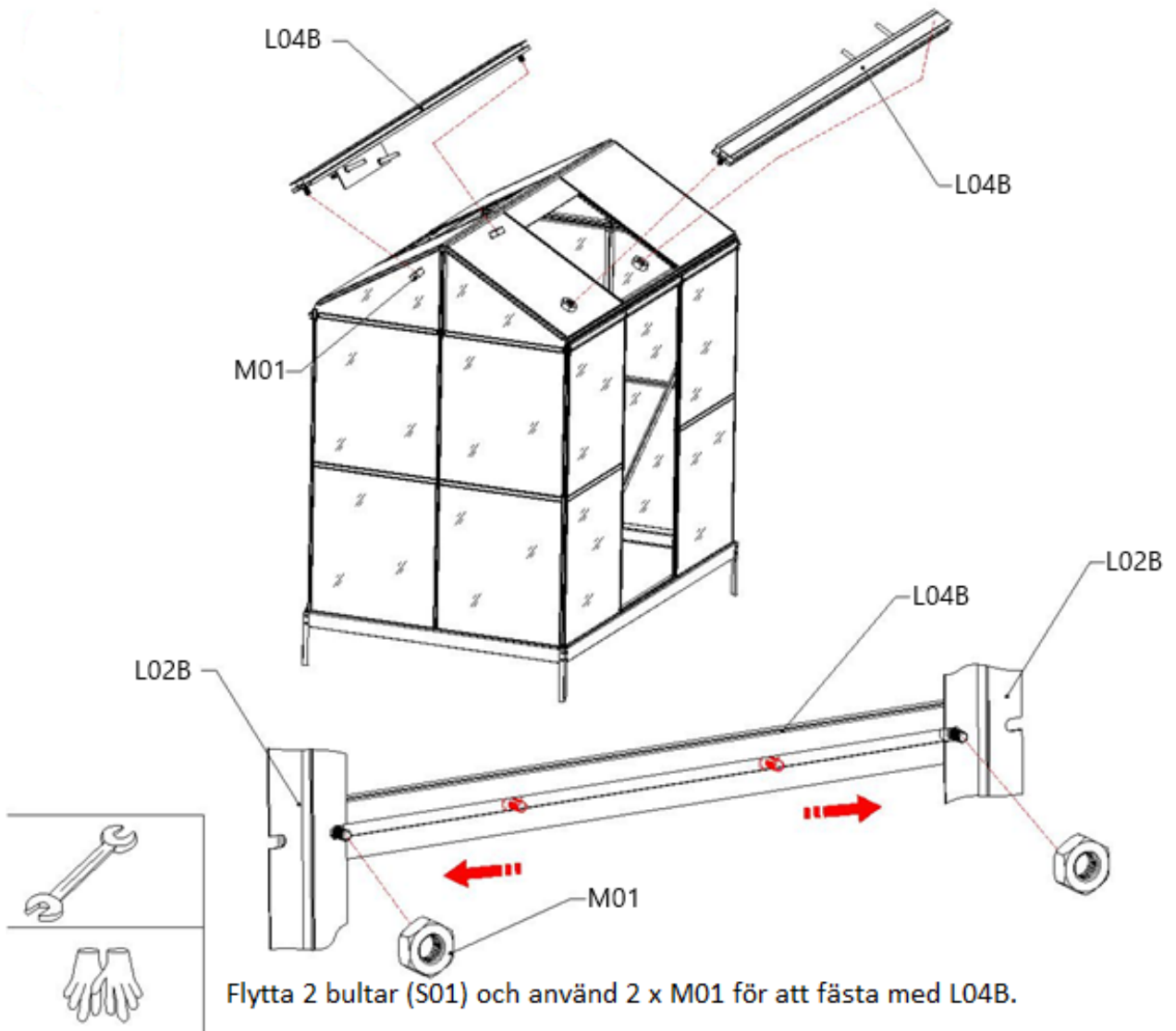

Flytta 2 bultar (S01) och använd 2 x M01 för att fästa med A03 och skjut sedan 2 bultar (S01) till L04B -bultkanalen igen.

X2



Flytta 2 bultar (S01) och använd 2 x M01 för att fästa med L04B.

Del	#	Antal
	Fönster	2
	Y4	2
	M01 M6	4

1. Fäst 2 x fönster till L02B
2. Skjut polykarbonatpanelerna på plats

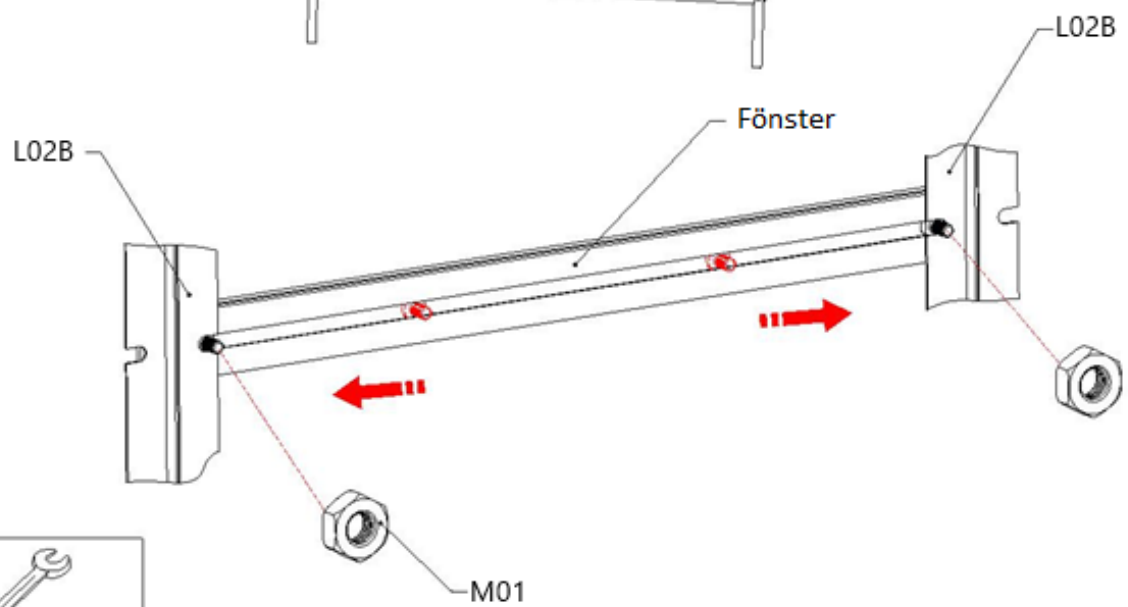
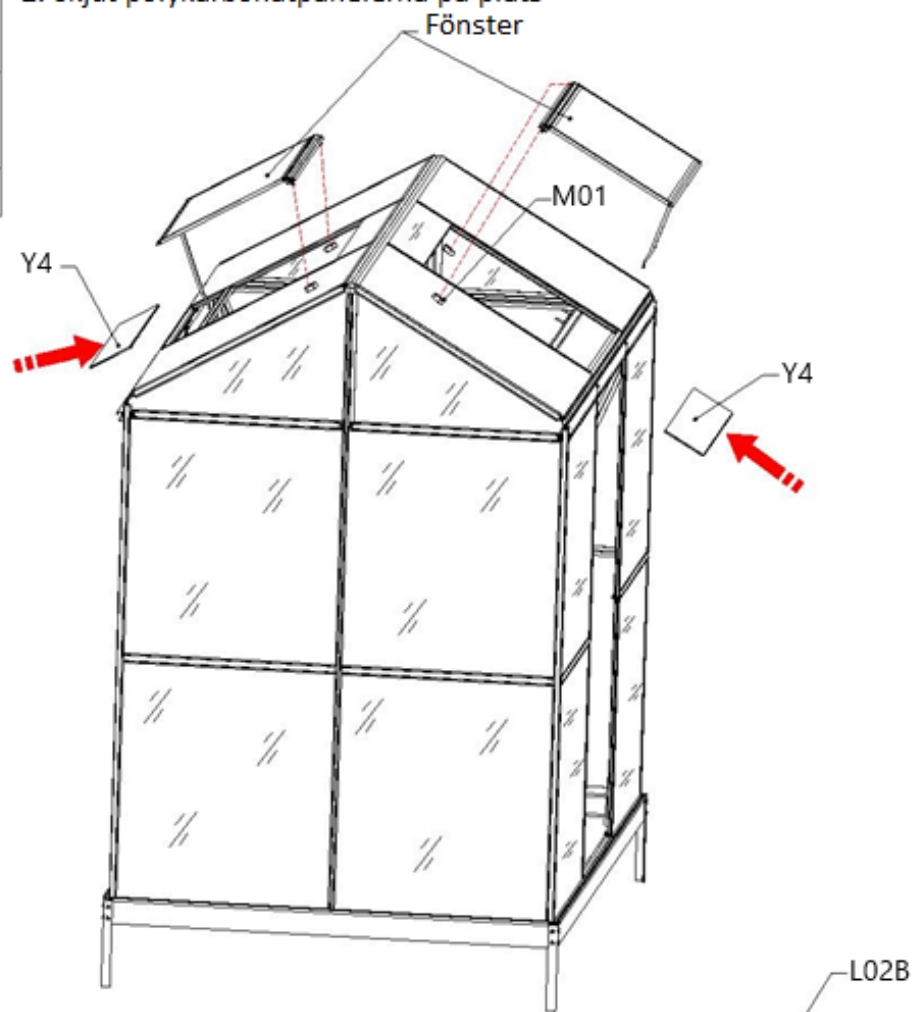

Flytta 2 bultar (S01) och använd 2 x M01 för att fästas med fönster.



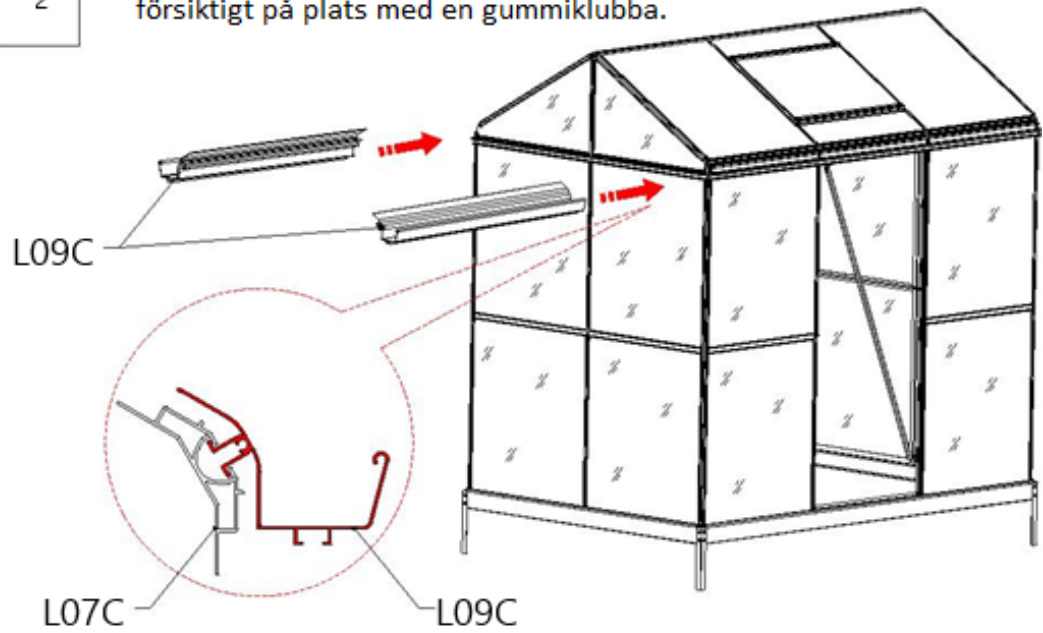

Del	#	Antal
	L09C	2

När panelerna är helt isatta, fixera rännprofilen L09C. Knacka försiktigt på plats med en gummiklubba.

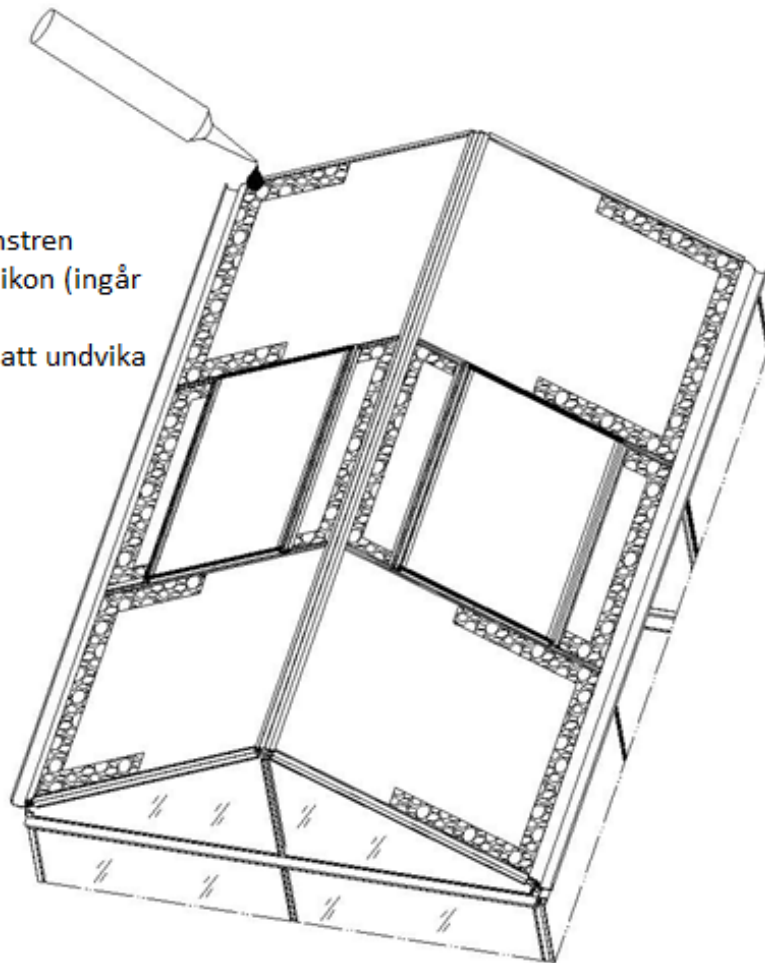

Efter panelerna och fönstren är på plats, lägg lite silikon (ingår ej) tätningsmedel runt för att undvika läckande vatten.









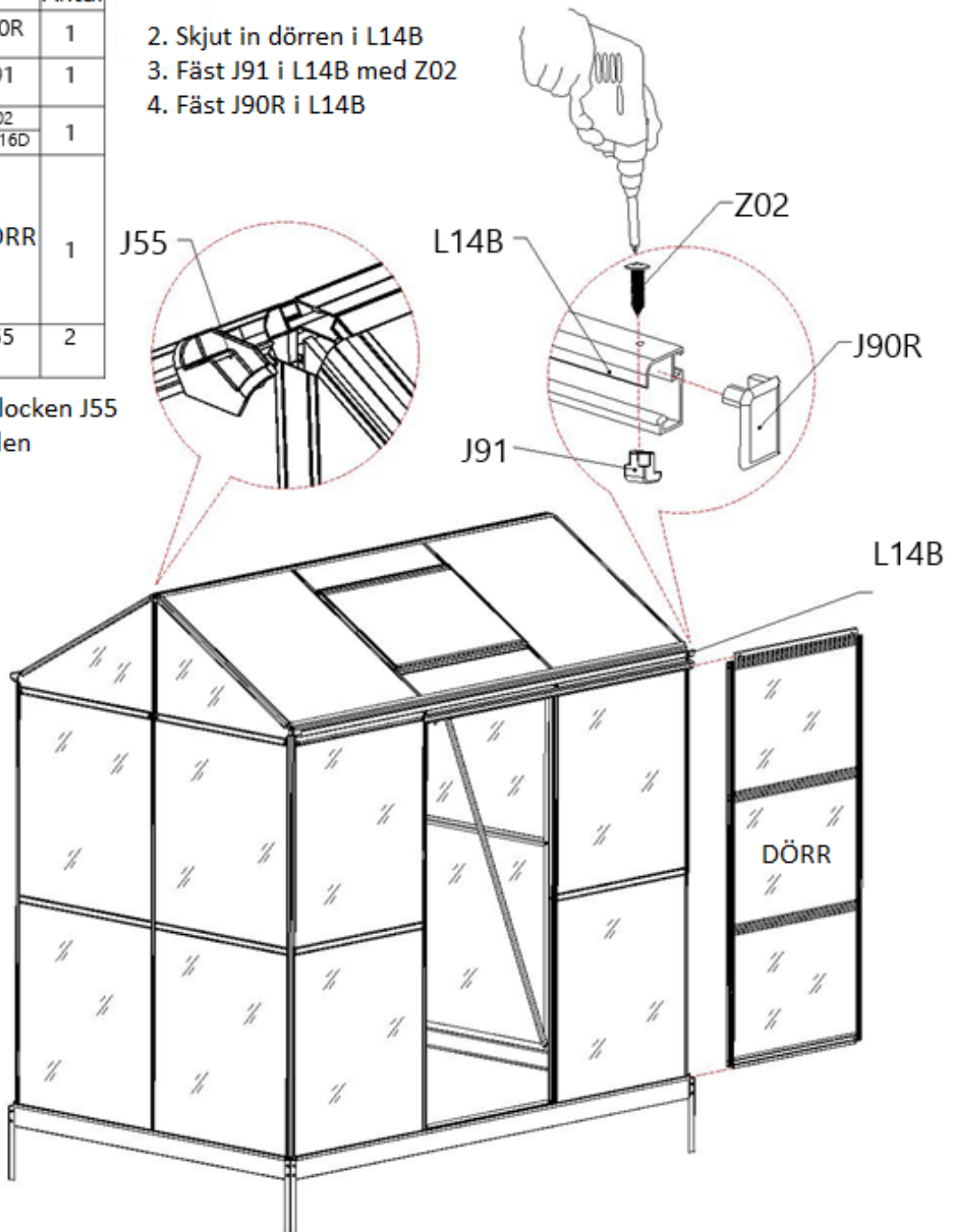



Del	#	Antal
	J90R	1
	J91	1
	Z02 Ø4X16D	1
	DÖRR	1
	J55	2

2. Skjut in dörren i L14B
3. Fäst J91 i L14B med Z02
4. Fäst J90R i L14B

1. Fäst täcklocken J55 in i åsprofilen



Del	#	Antal
	J55	2
	J56R	2
	J56L	2
	J94	4
	L25	4
	J93	4
	J92	4
	Z08	4
	M4.2X16	
	Z02	8
	Ø4X16D	

Borra ett hål i L01A cirka 3 mm i diameter och 700 mm uppifrån. Fixera J92 -röret med Z08 -skruvar och fäst sedan nedloppsroret L25 in i J92 fäste.

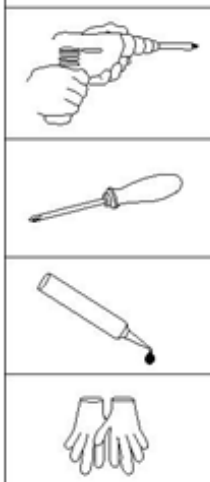
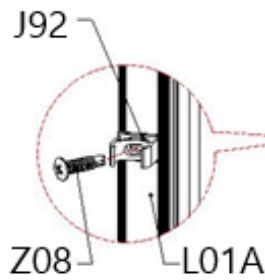

Slutförande: Gör en sista undersökning och kontrollera att alla skruvar, bultar och muttrar sitter ordentligt.

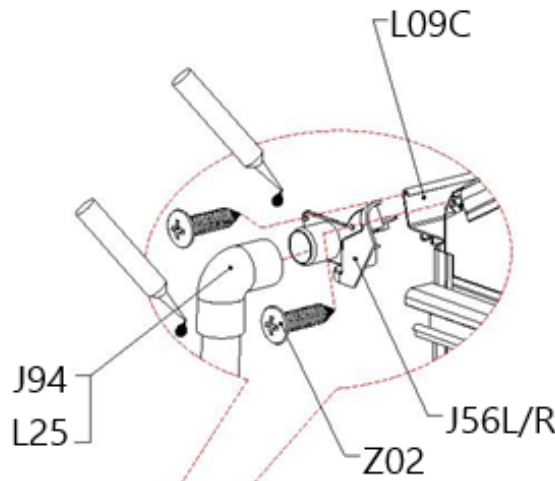



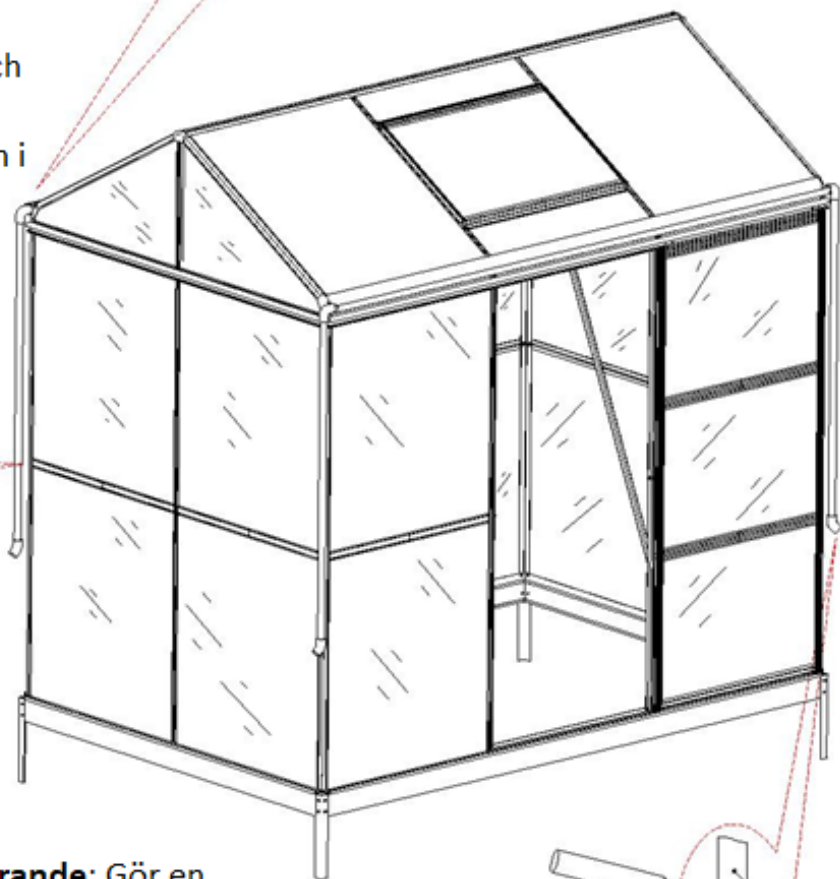

Fäst täcklocken (J56L/R) försiktigt med Z02. Var noga med att skruvarna dras rakt och i rätt läge (se detaljritning).

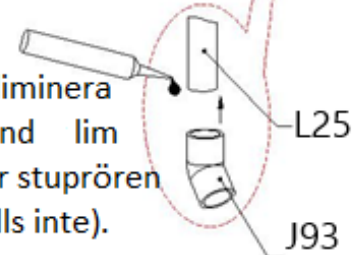

Om du vill eliminera läckor, använd lim när du fäster stupröret (tillhandahålls inte).



Del	#	Antal
	L05A	3
	L02C	2
	S01 M6X12	8
	M01 M6	8

Montera dörr på kortsida

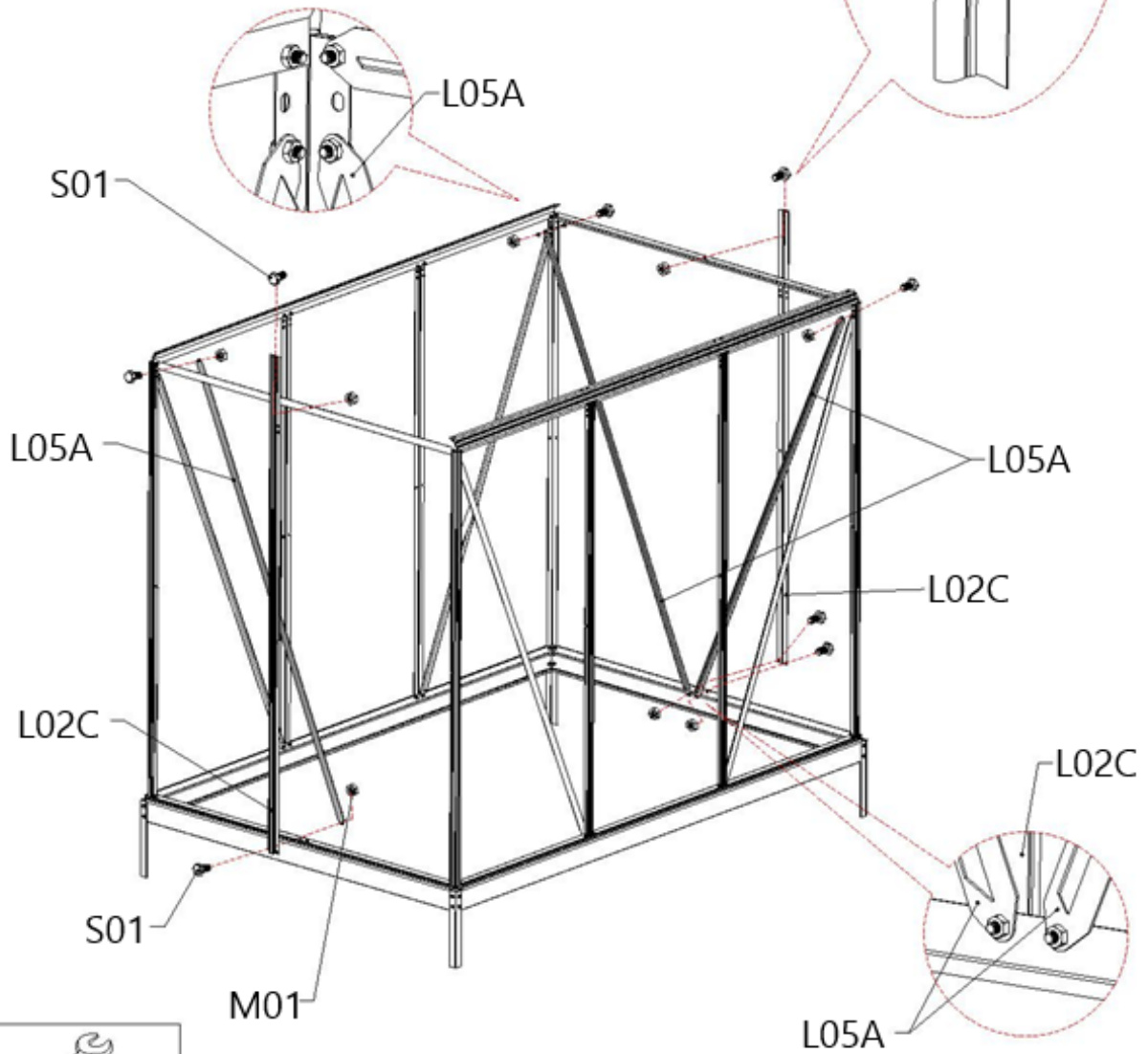
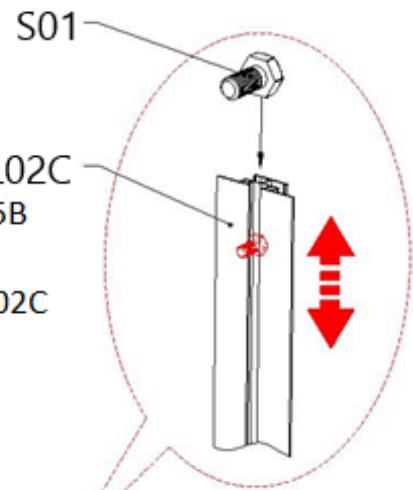

1. Skjut in 2 x S01 i 2 x L02C -bultkanal. L02C
2. Fäst 2 x L02C på L10B, L10C och L05B med S01 & M01.
3. Fäst stöden 3 x L05A till L01A och L02C med S01 & M01.

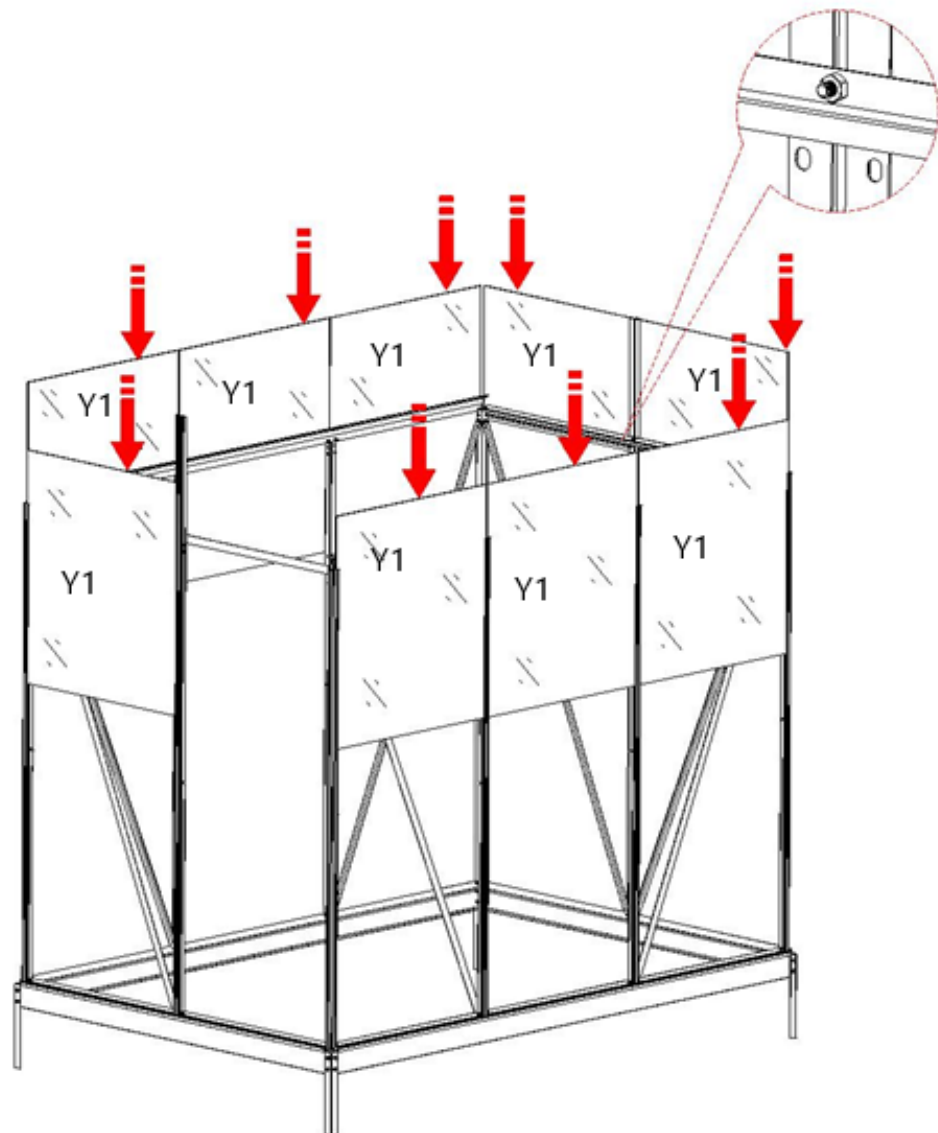

Del	#	Antal
	Y1	9

Skjut glasrutorna på plats



Del	#	Antal
	L04B	11
	S01	22
	M6X12	

Skjut in 2 x S01 i L04B-bultkanalen.

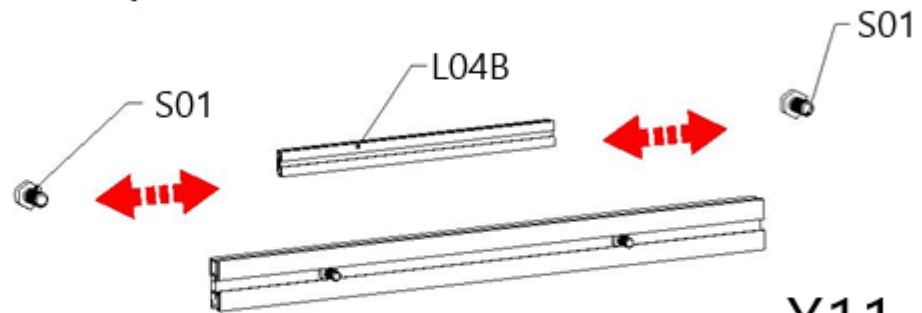

X11

Fäst stöden L04B (9st) enligt nedan, med S01 & M01.

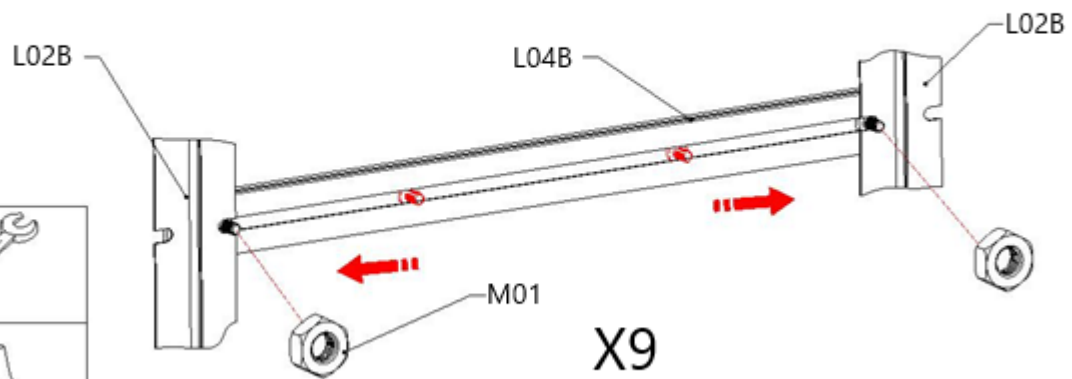
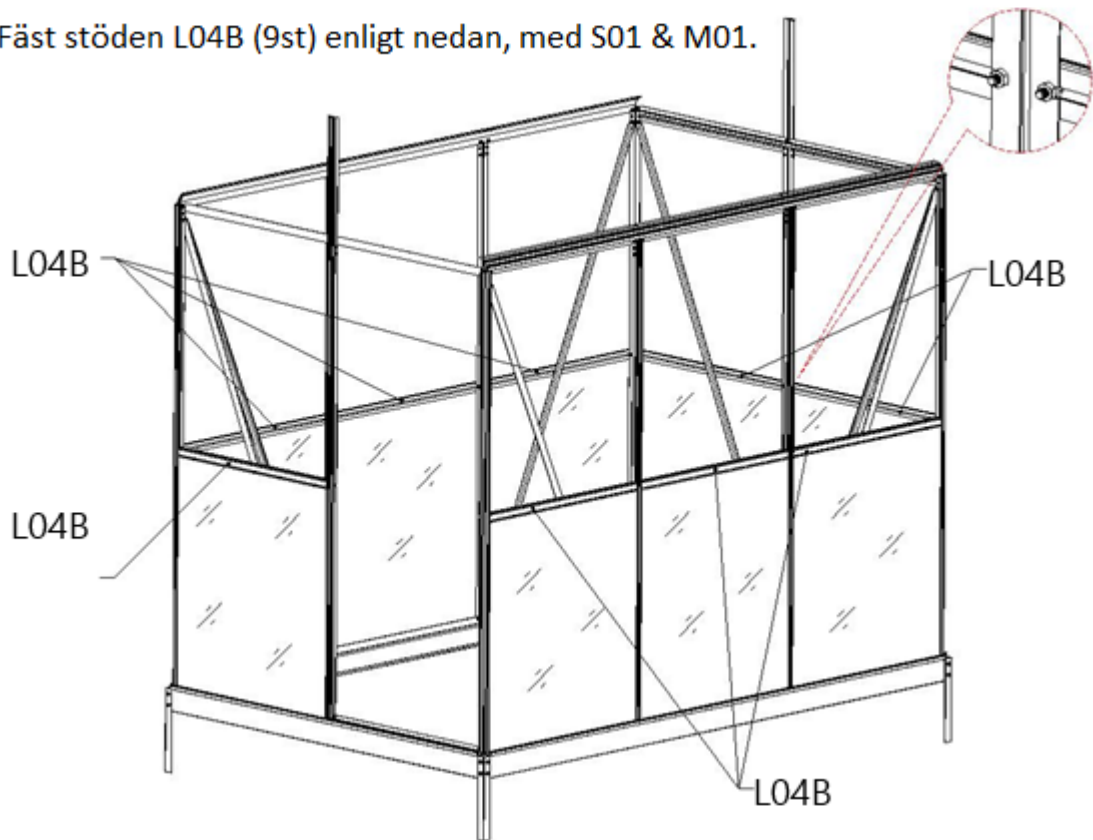

Flytta 2 bultar (S01) och använd 2 x M01 för att fästa L04B.

Del	#	Antal
	Y1	9

Skjut glasrutorna på plats

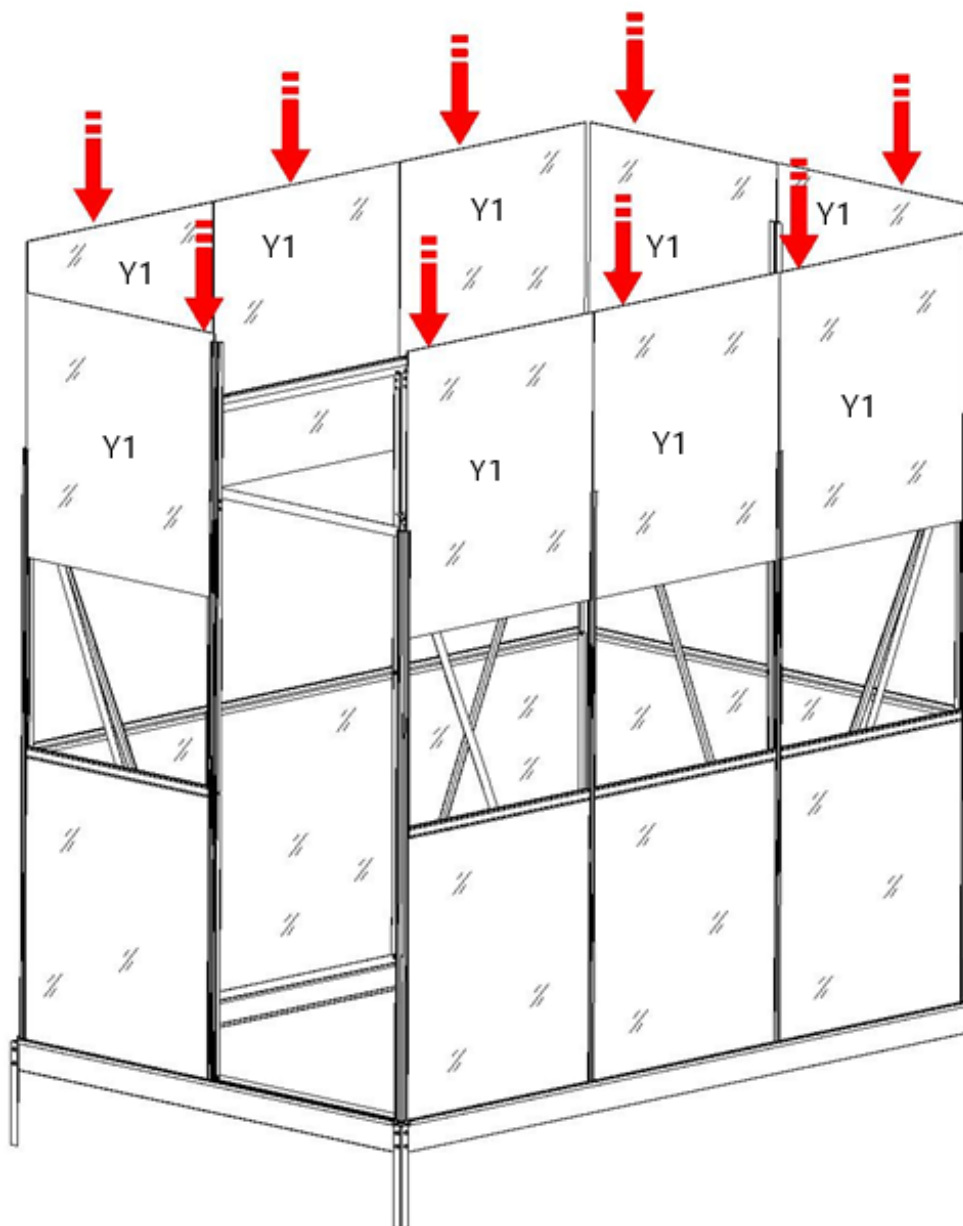



	L04A	2
	S02	4
	M6X20	
	M01	4
	M6	

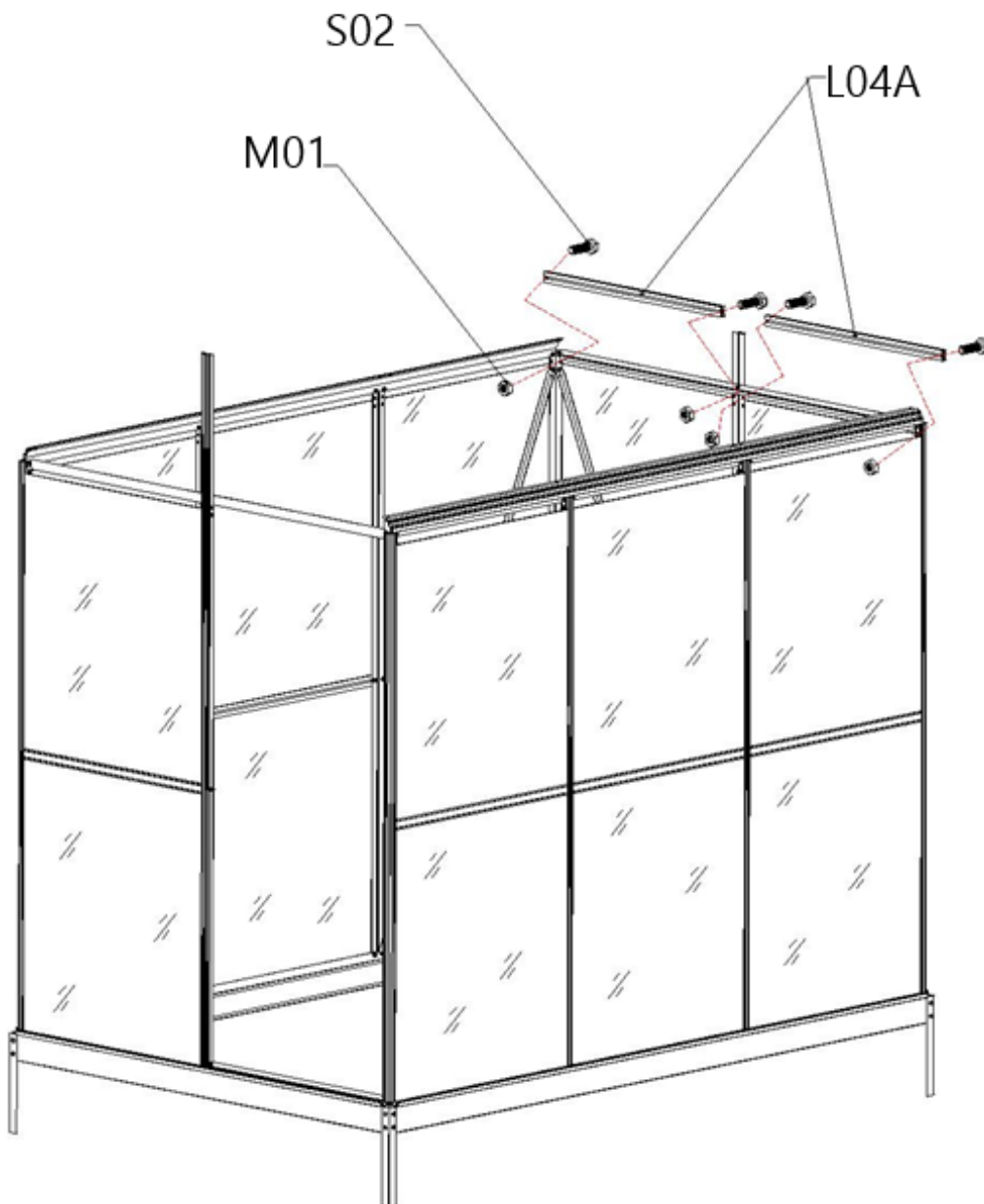

Fäst stöden L04A (2st) enligt nedan, med S02 och M01.



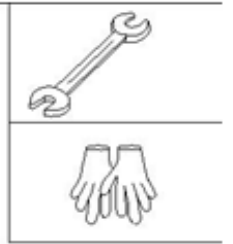

Del	#	Antal
	L26	6
	S02 M6X20	12
	M01 M6	12

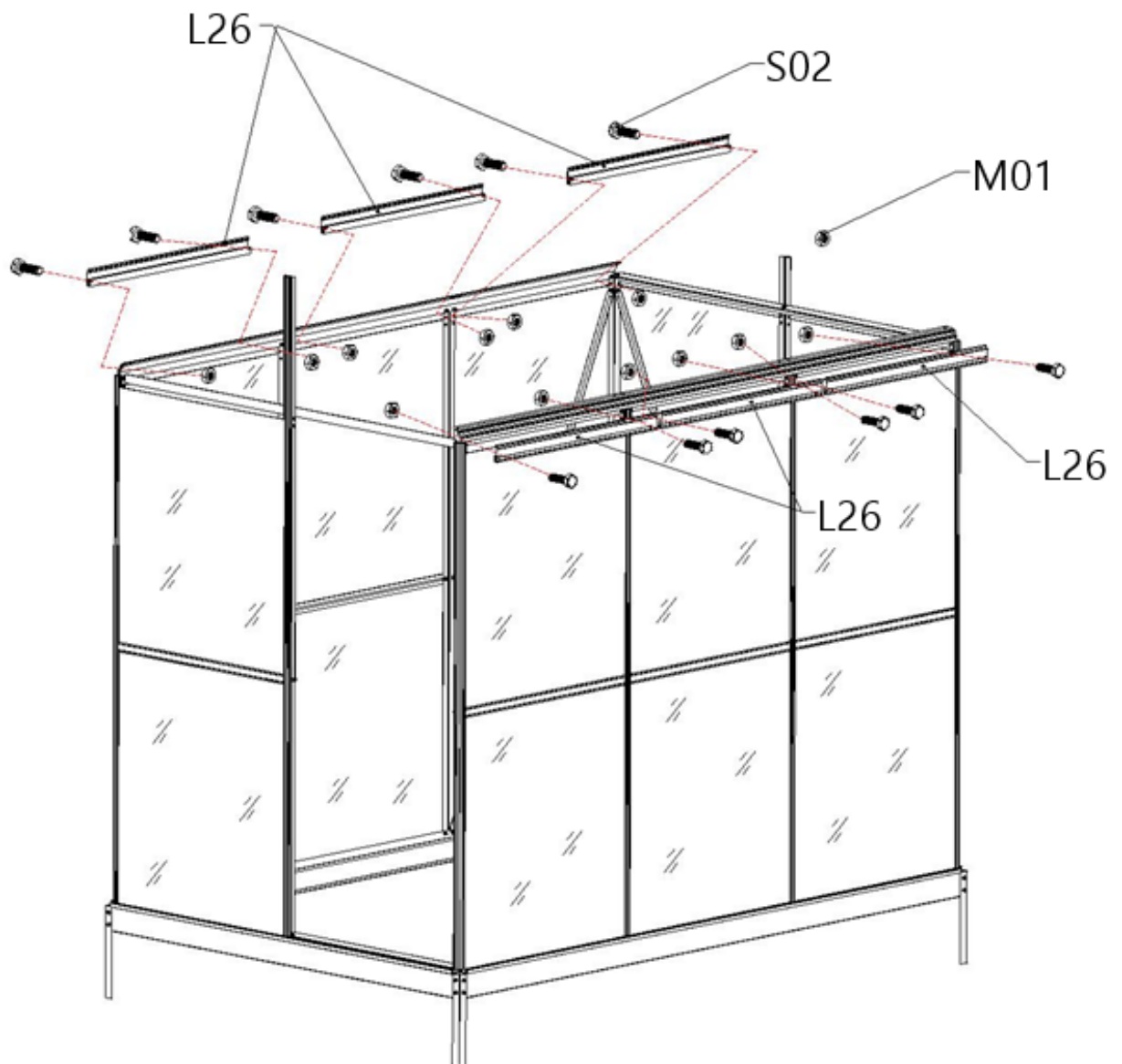

Fäst 6 x L26 med S02 och M01.



Del	#	Antal
	L04A	2
	S02	4
	M01	4
	M6X20	
	M6	

1. Fäst bromsar L04A (2st) enligt nedan med S02 & M01, men dra inte åt bultarna/muttrarna.

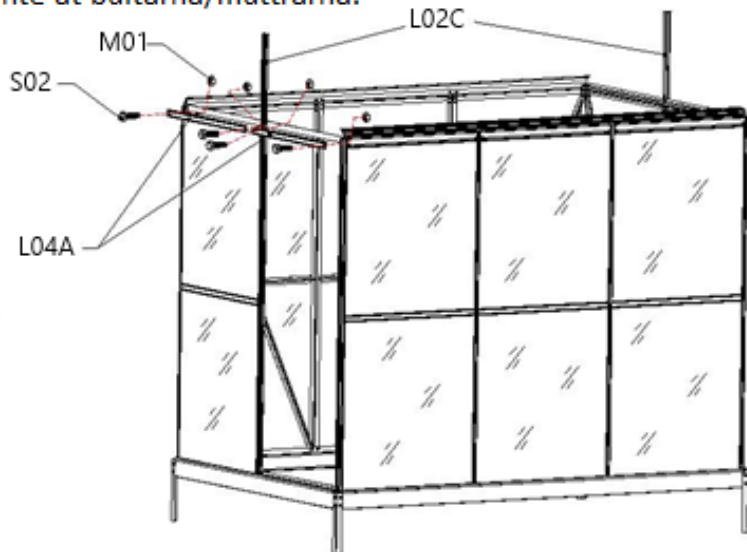

2. Tryck muttrarna inifrån

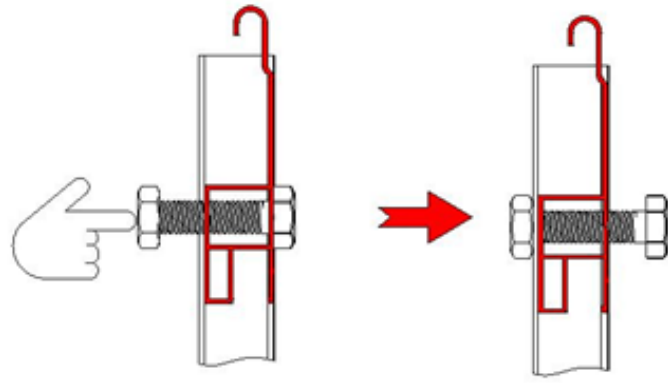

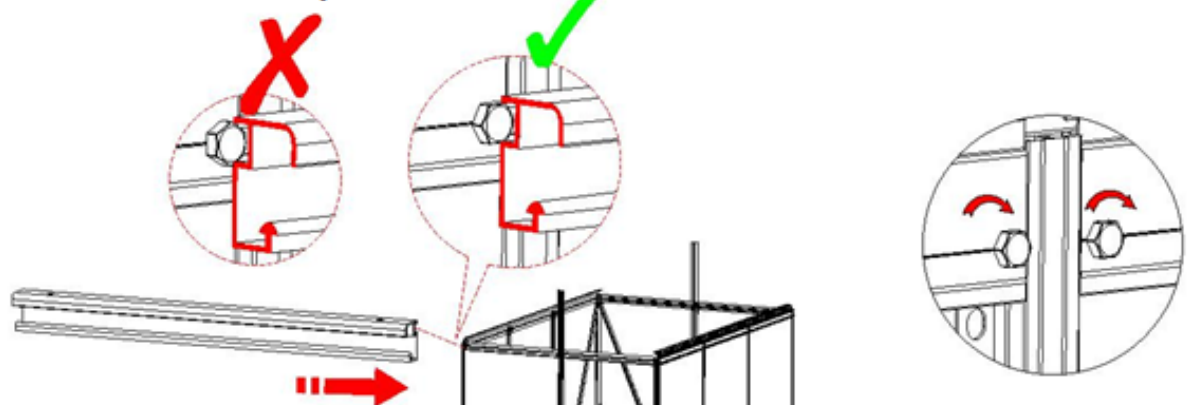

3. Vrid bultarna för att skjuta L14B

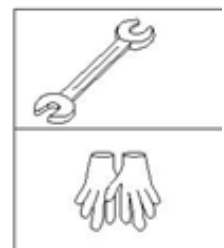
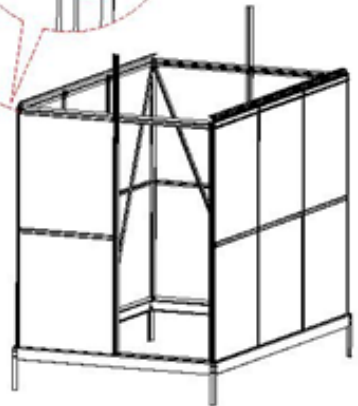

4. Dra åt bultarna/muttrarna





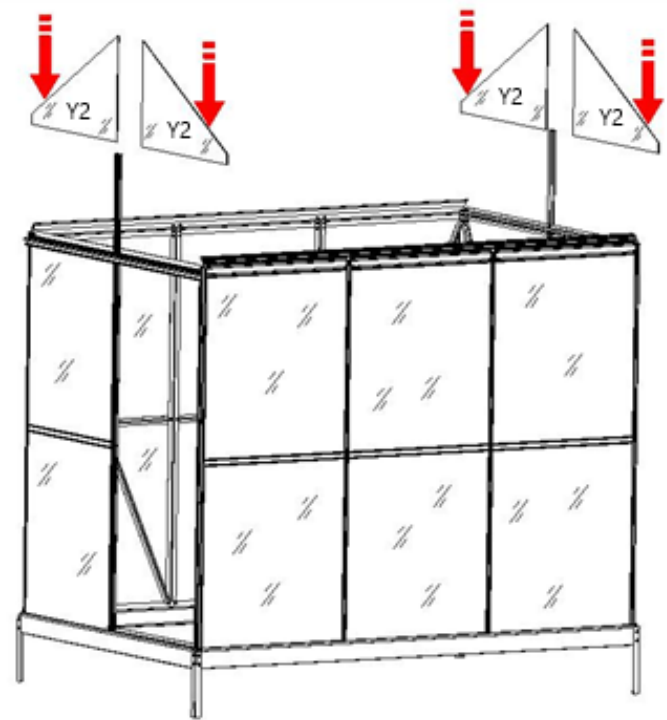

Del	#	Antal
	L01B	4
	Y2	4
	S01 M6X12	6

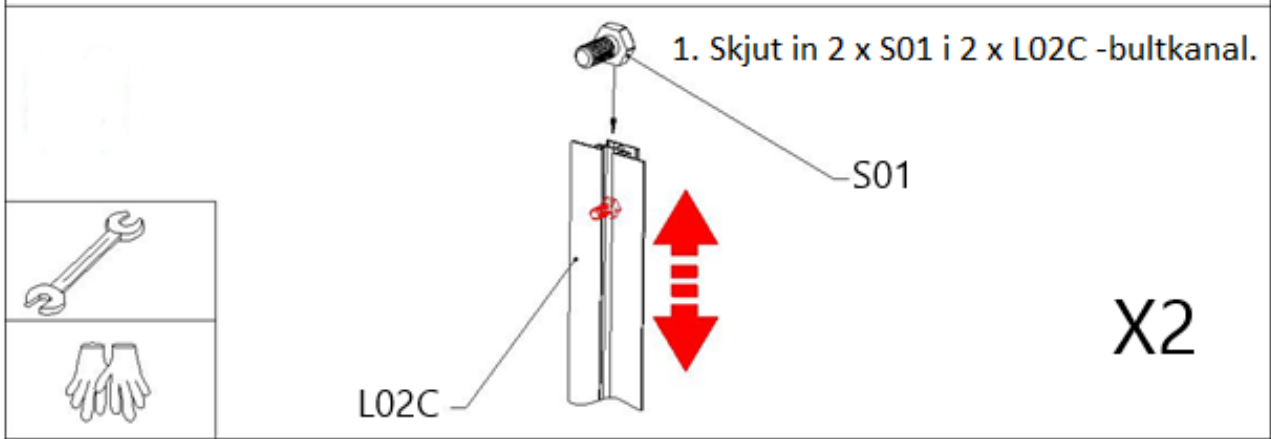
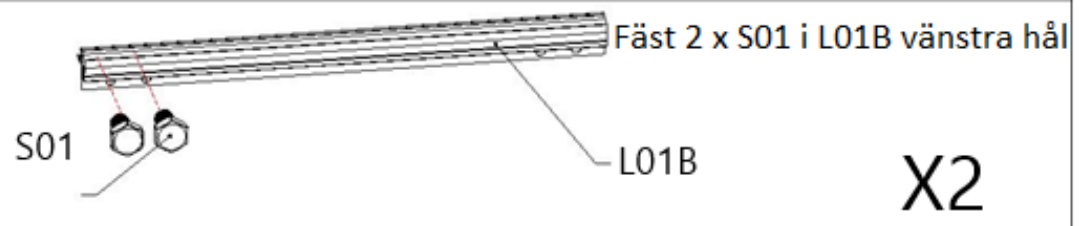
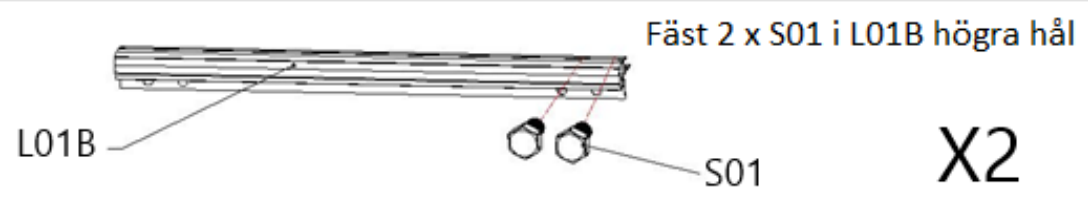

Skjut glasrutorna på plats





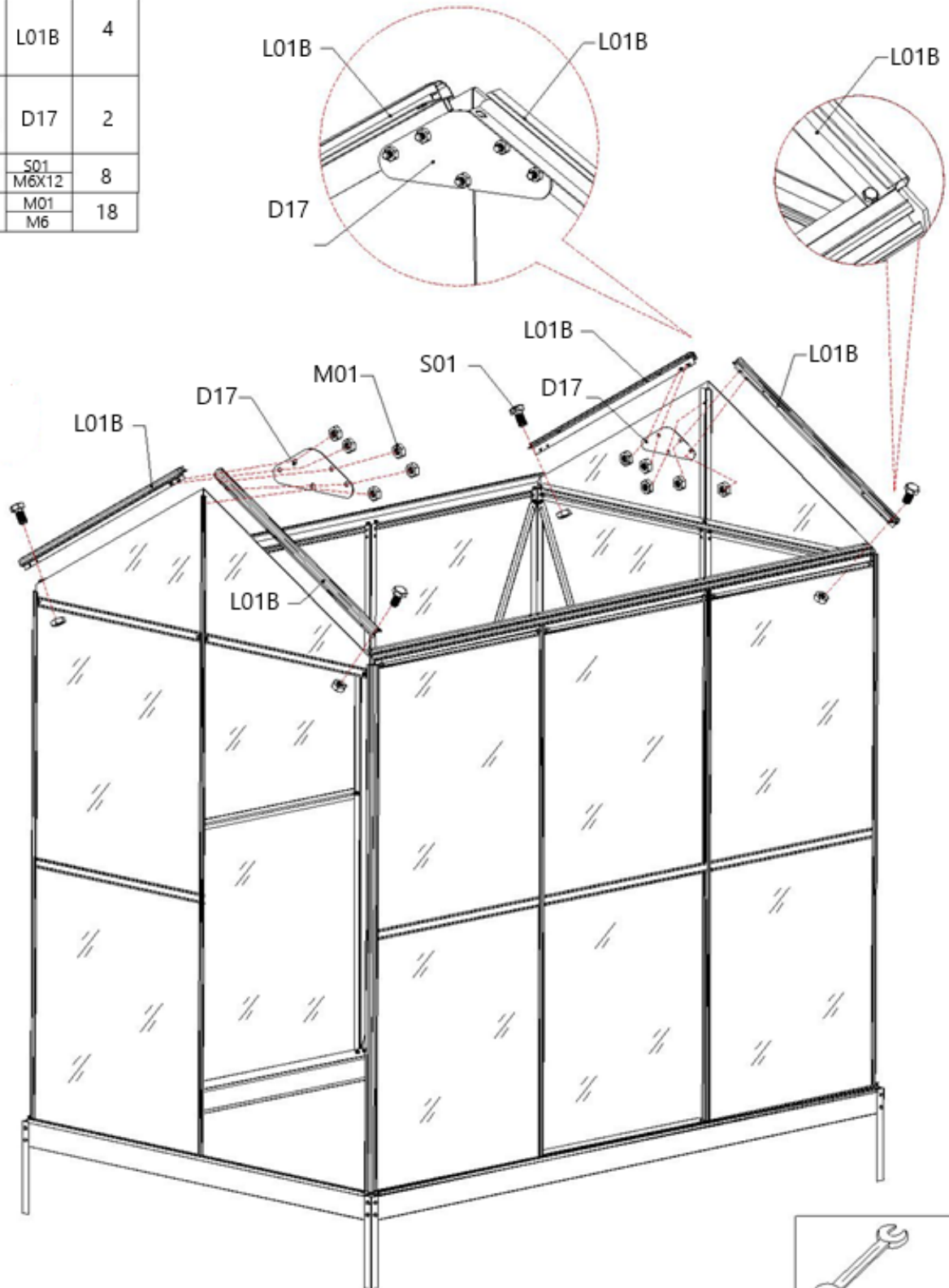



Del	#	Antal
	L01B	4
	D17	2
	S01 M6X12	8
	M01 M6	18





Fäst L01B med plattan D17 med S01 och M01 förinstallerad ovan.



Del	#	Antal
	L02B	4
	L06C	1
	S01	20
	M01	
	M01	20
	M6	

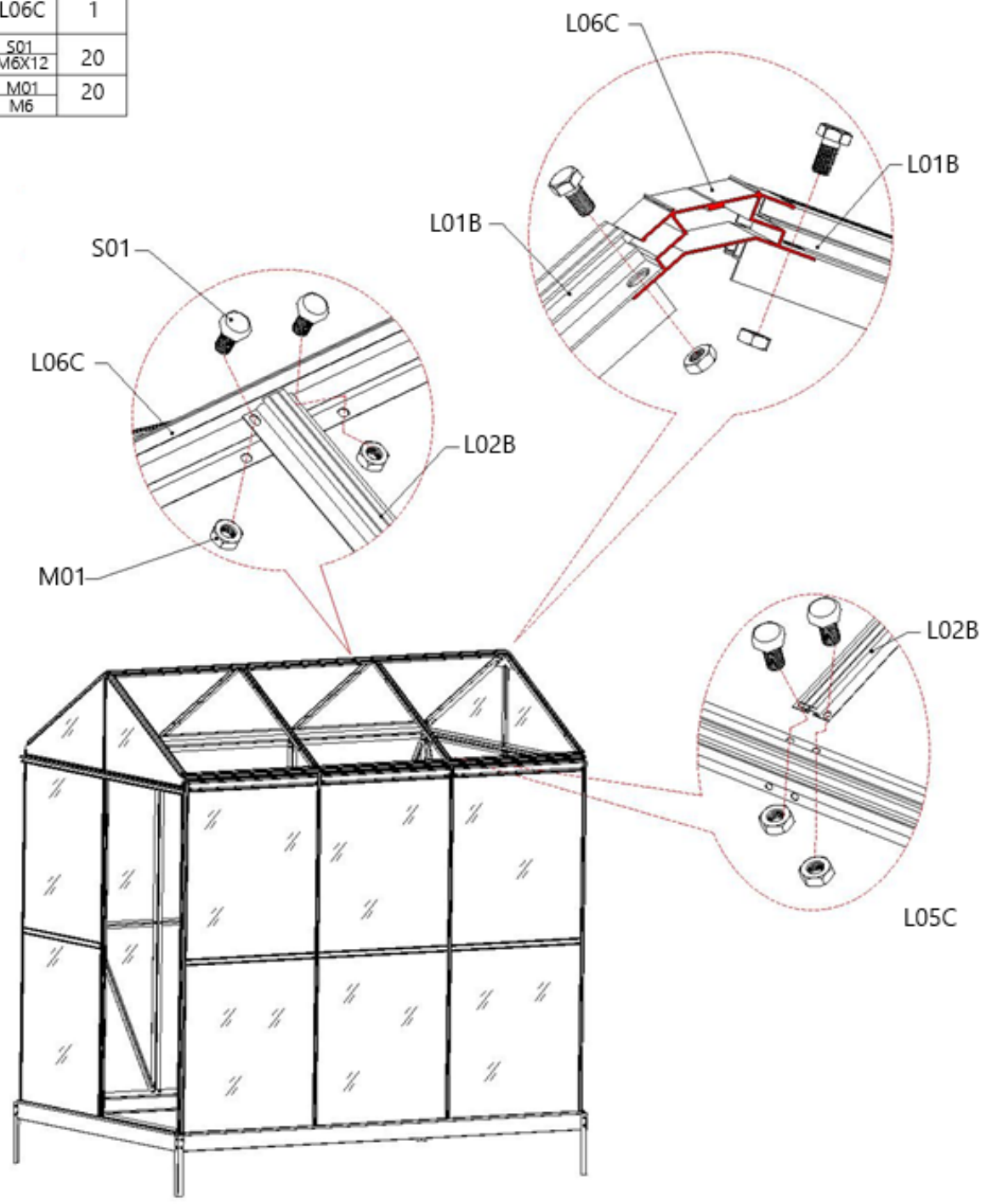



1. Fäst takfoten 1x L06C med S01 & M01.
2. Fäst glasrutor 4 x L02B med S01 & M01.

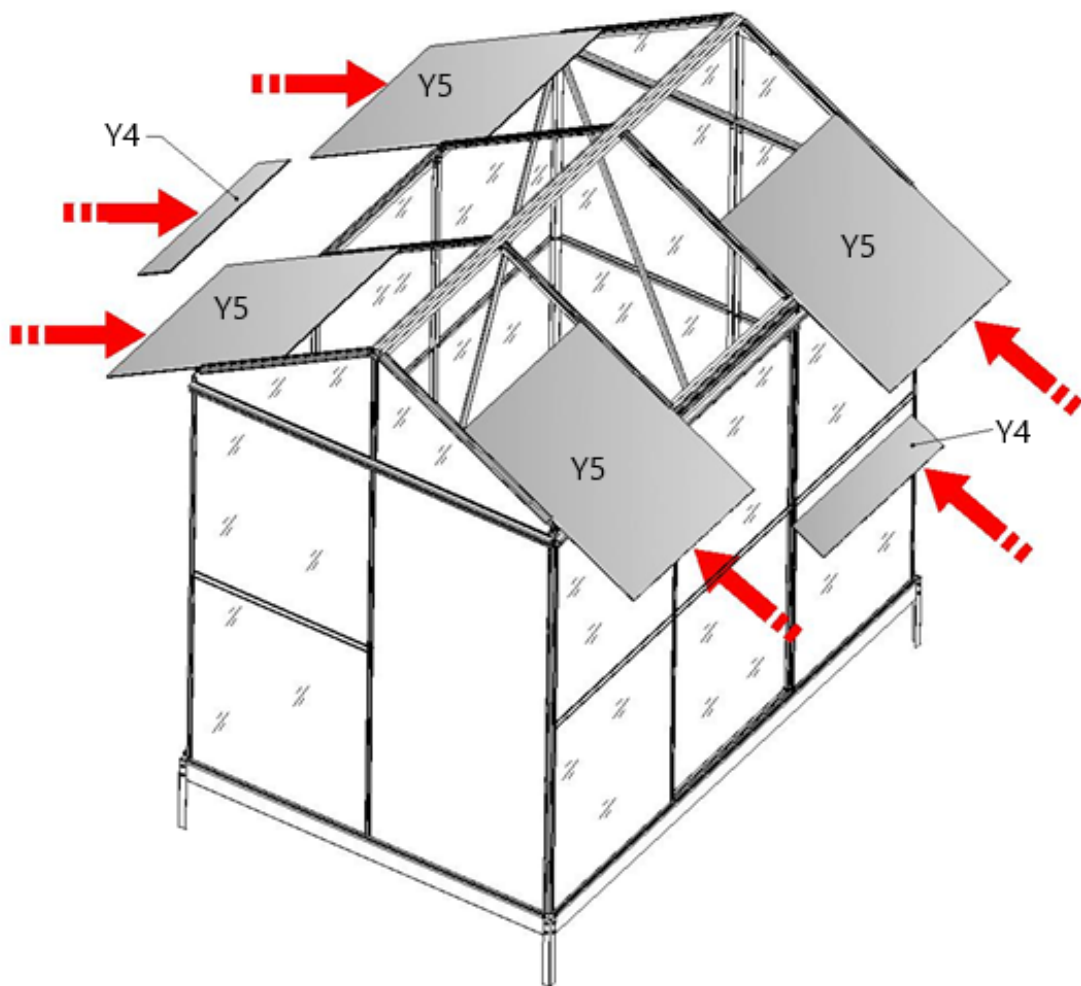

Del	#	Antal
	Y4	4
	Y5	4

Skjut polykarbonatpanelerna (kanalplast) på plats



Del	#	Antal
	L04B	2
	A03	2
	S01 M6X12	4
	M01 M6	8

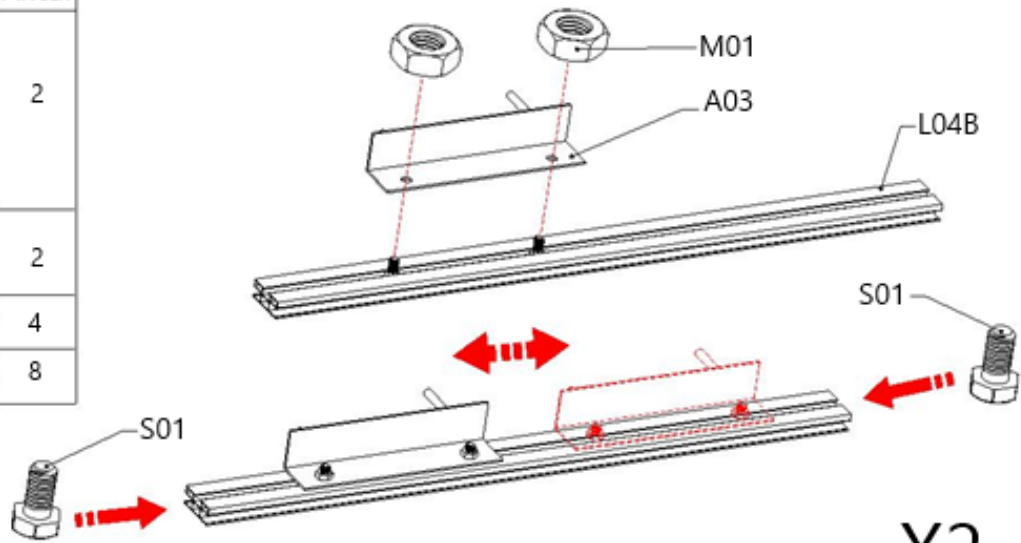

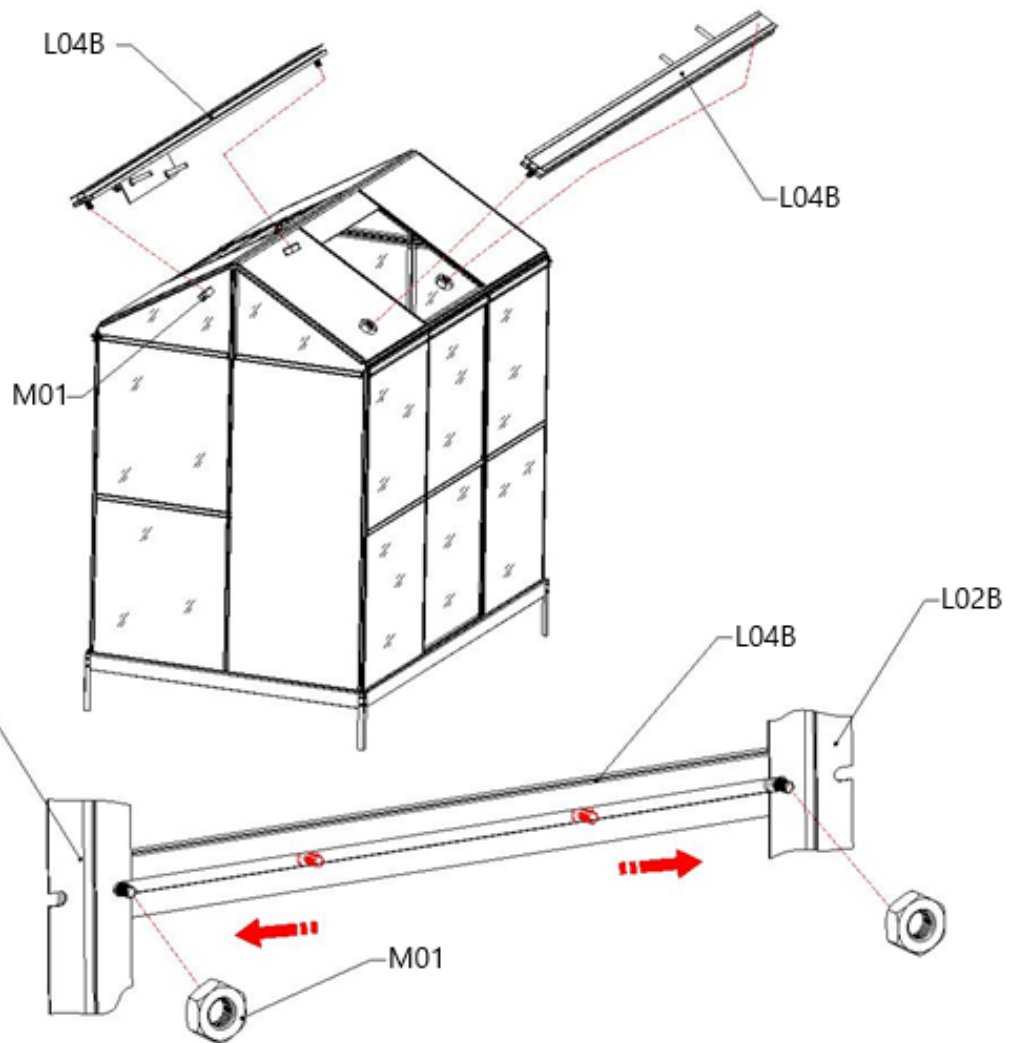

Flytta 2 bultar (S01) och använd 2 x M01 som ska fästas med A03 **X2**
och skjut sedan 2 bultar (S01) till L04B -bultkanalen igen.

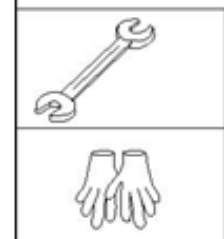

Flytta 2 bultar (S01) och använd 2 x M01 som ska fästas med L04B.



Del	#	Antal
	Fönster	2
	Y4	2
	M01 M6	4

1. Fäst 2 x fönster till L02B

2. Skjut polykarbonatpanelerna (kanalplast) på plats

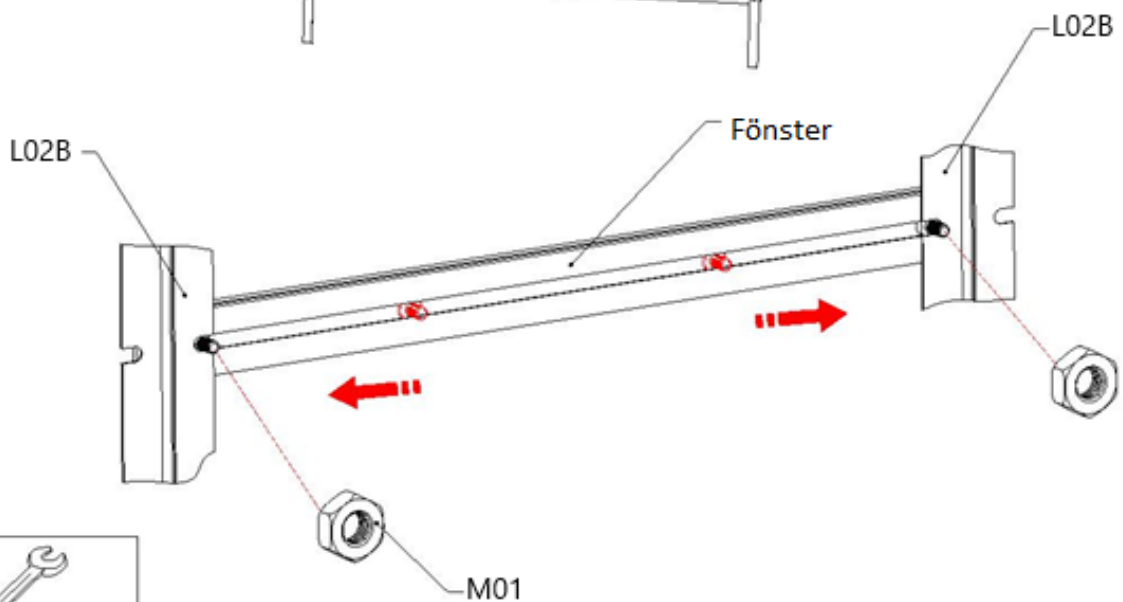
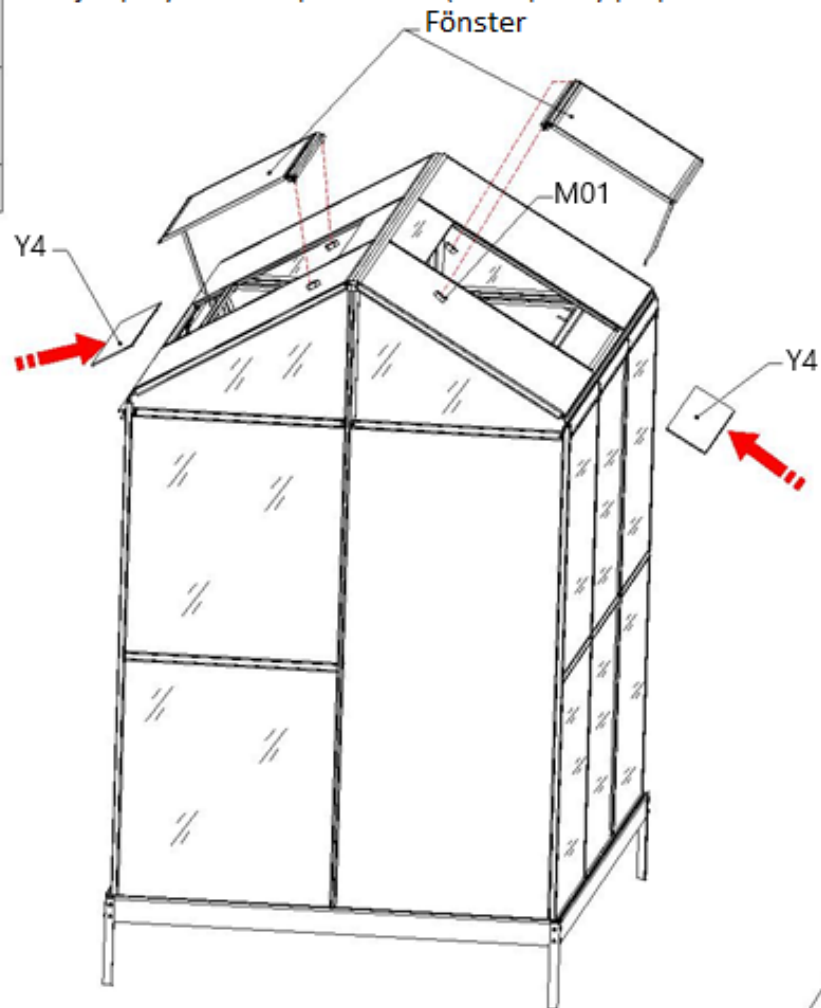

Flytta 2 bultar (S01) och använd 2 x M01 för att fästas med fönster.

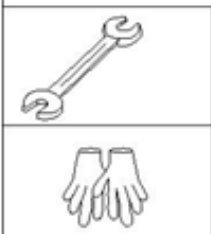

Del	#	Antal
	L09C	2

När panelerna är helt isatta, fäst rännprofilen L09C. Knacka försiktigt på plats med en gummiklubba.

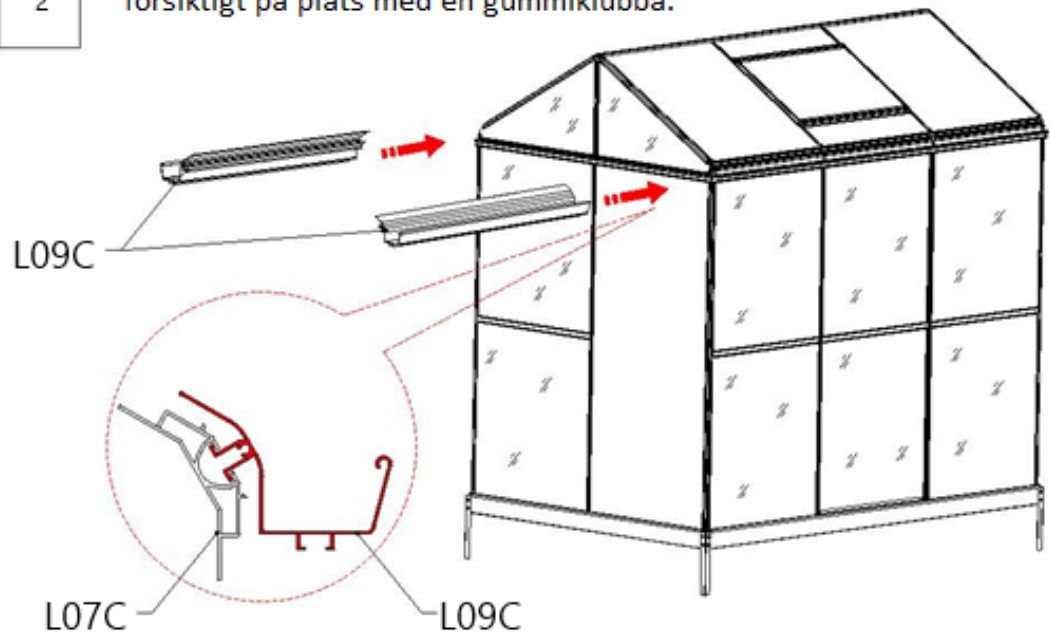

Efter panelerna och fönstren är på plats, lägg lite silikon (medföljer ej) tätningsmedel runt för att undvika läckande vatten.

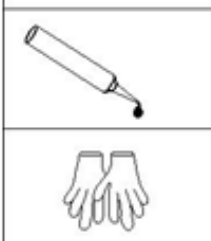
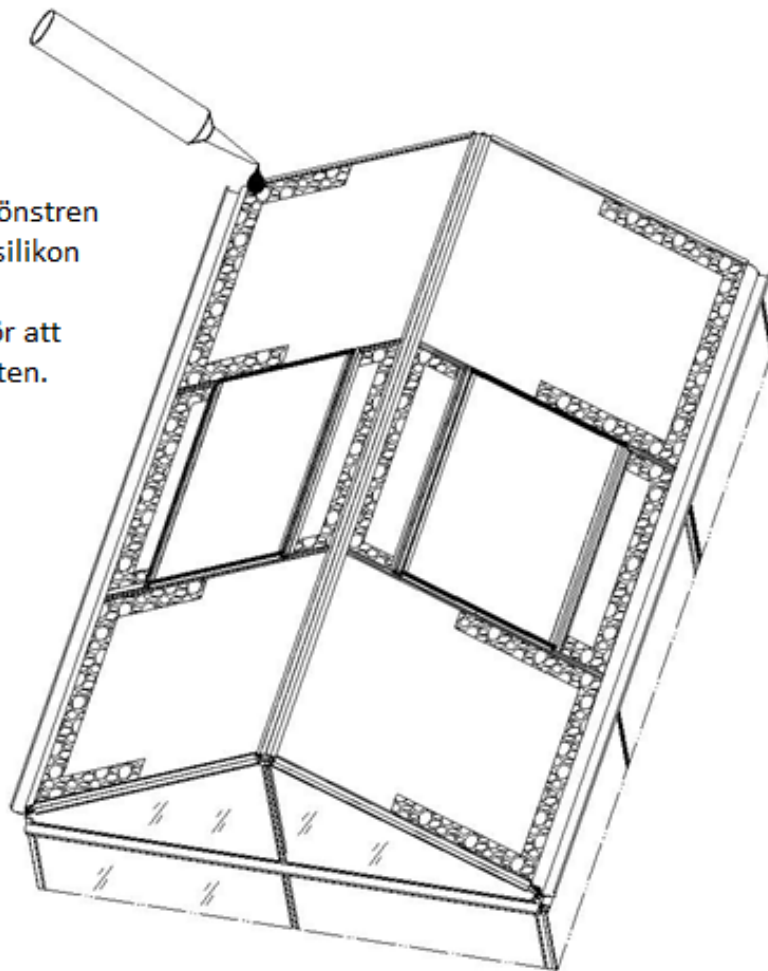





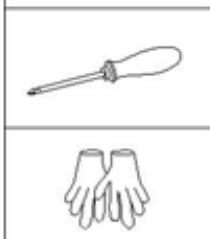
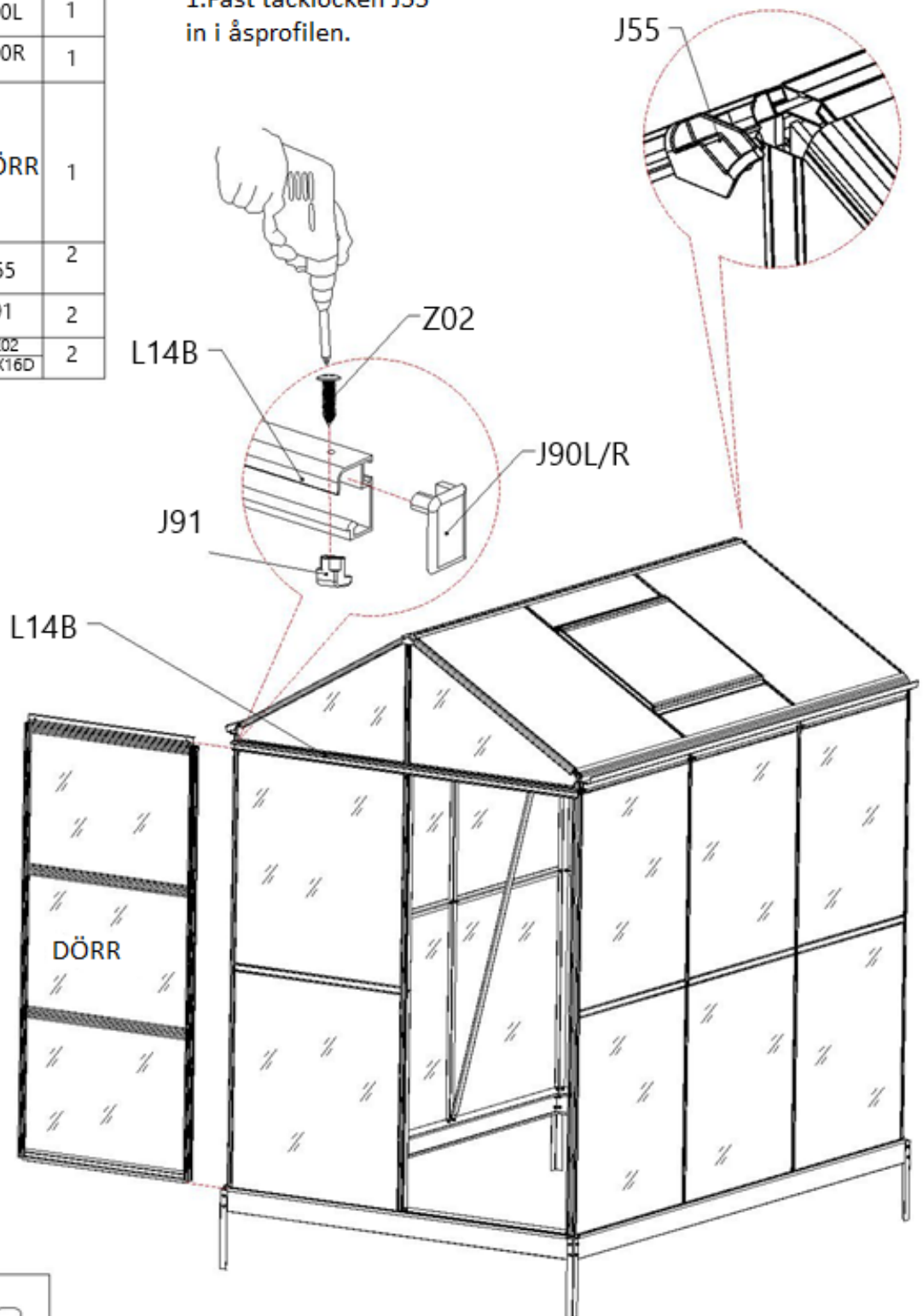





Del	#	Antal
	J90L	1
	J90R	1
	DÖRR	1
	J55	2
	J91	2
	Z02 Ø4X16D	2

1. Fäst täcklocken J55
in i åsprofilen.



2. Skjut in dörren i L14B
3. Fäst 2 x J91 i L14B med Z02
4. Fäst J90L/R i L14B

Del	#	Antal
	J55	2
	J56R	2
	J56L	2
	J94	4
	L25	4
	J93	4
	J92	4
	Z08	4
	M4.2X16	
	Z02	8
	Ø4X16D	

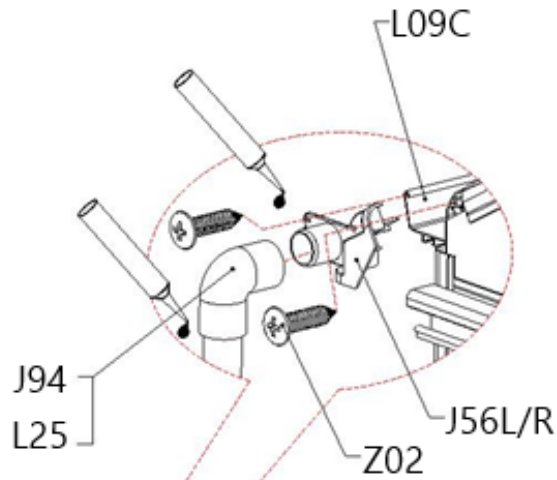

Fäst täcklocken (J56L/R) noggrant med Z02. Var försiktig för att säkerställa att skruvarna drivs in rakt och i rätt position (se detaljritning).

Borra ett hål i L01A cirka 3 mm i diameter och 700 mm uppifrån. Fäst J92 -röret med Z08 -skruvar och fäst sedan stupröret L25 in i J92 fäste.

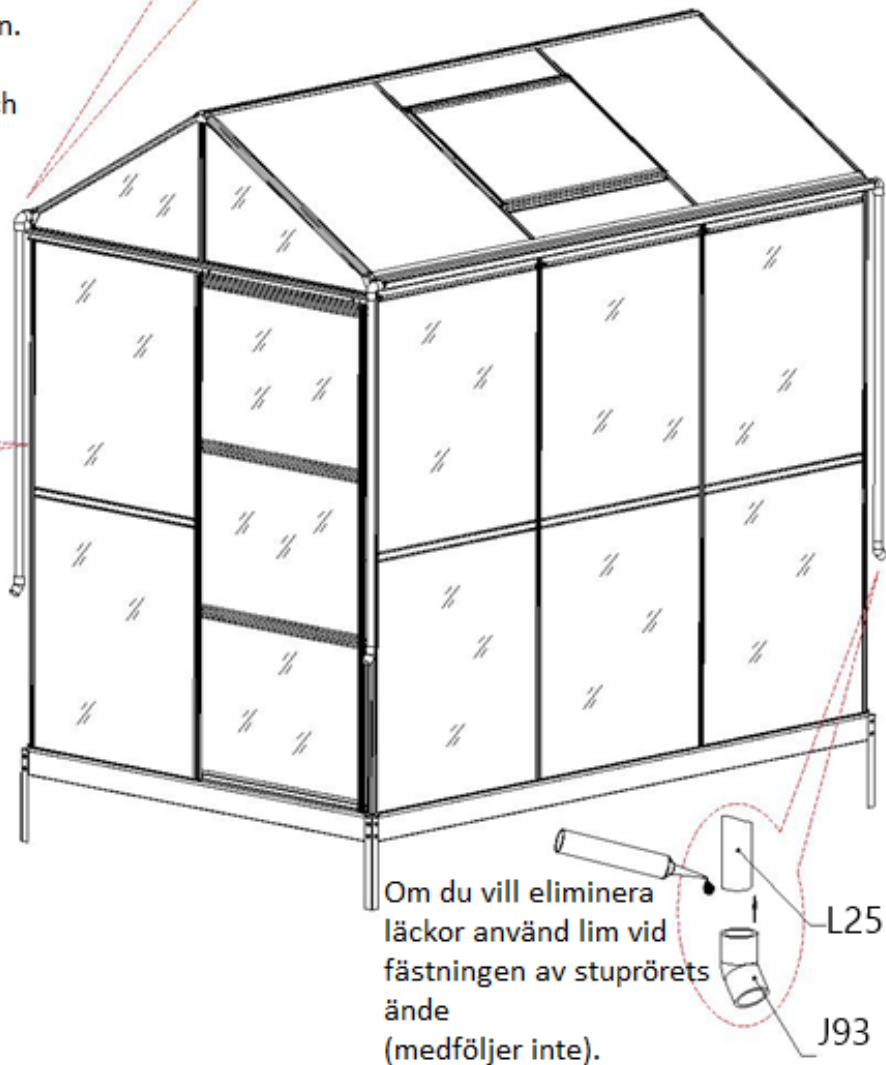
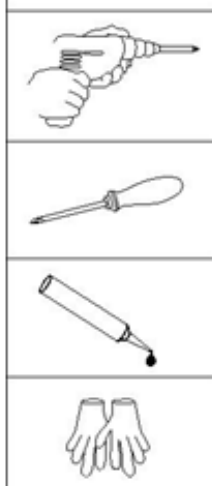
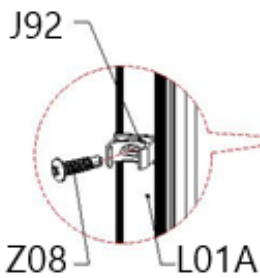

Om du vill eliminera läckor använd lim vid fästningen av stuprörets ände (medföljer inte).

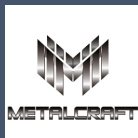

Konsumentkontakt
Arc E-commerce AB
Box 3124
13603 Haninge
Sverige