

**METALCRAFT**

## Monteringsanvisning

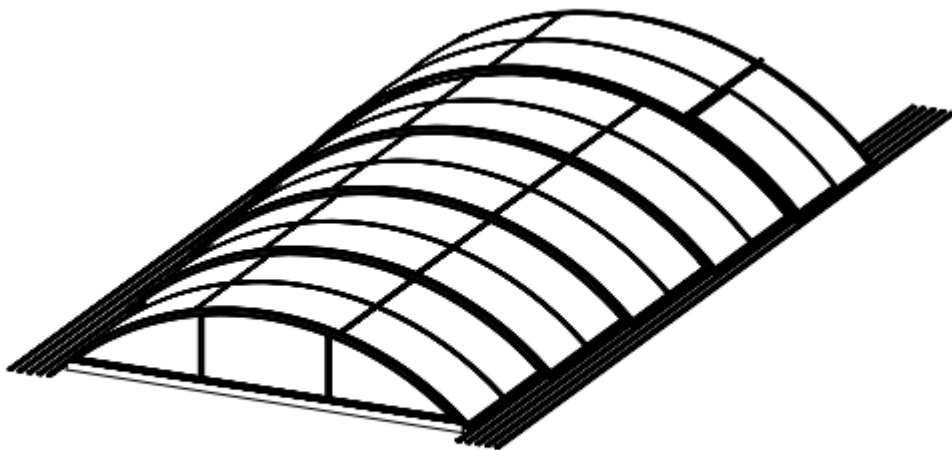

MODELL 142-2-7

STORLEK (L x B x H): 641 x 1 275 x 146 cm

LÄS IGENOM NOGGRANT FÖRE MONTERING

## Monterings- och underhållsanvisningar

1. För din säkerhet, rekommenderar vi att pooltaket monteras av minst tre personer.
2. Några delar har vassa metallkanter. Var försiktig när du hanterar metall- delar. Bär handskar, skor och skyddsglasögon under monteringen.
3. KLÄTTRA INTE och STÅ INTE på pooltaket. Luta inga tunga föremål mot pooltaket.
4. Håll pooltaket fritt från snö, smuts och löv. Om du låter snö ansamlas på pooltaket kan skador uppstå.
5. När pooltaket behöver rengöras, använd en mild blandning av diskmedel och vatten. Skölj med kallt, rent vatten. Använd inte aceton, rengöringsmedel innehållande slipmedel eller andra starka rengöringsmedel vid rengöring av pooltakets paneler.

### Verktyg som ingår:

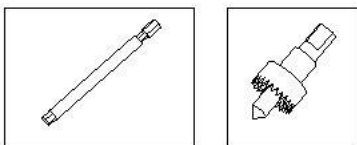



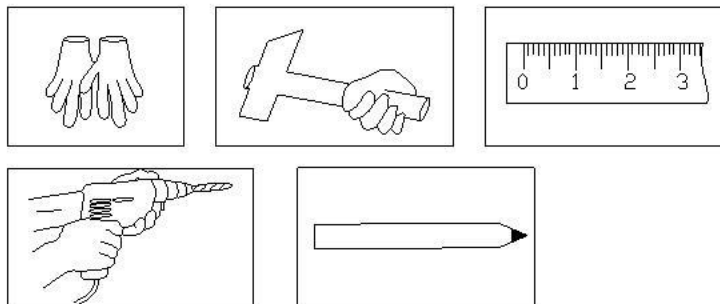





















### Verktyg som behövs vid monteringen (ingår inte)

















Monteras av minst tre personer



# 142-2-7 (aluminiumlåda)

DEL	NR.	ST.
	L01A	10
	01-L02A	1
	01-L02B	1
	02-L02A	2
	02-L02B	1
	03-L02A	2
	03-L02B	1
	04-L02A	2
	04-L02B	1
	05-L02A	1
	05-L02B	1
	01-L02G	2
	01-L02H	2
	L04A	20
	L05A	2
	L06A	30
	L08A	1
	L08B	1
	L09A	2
	L11	40
	L12	20
	L13	4
	K1-1	1
	K5-1	1



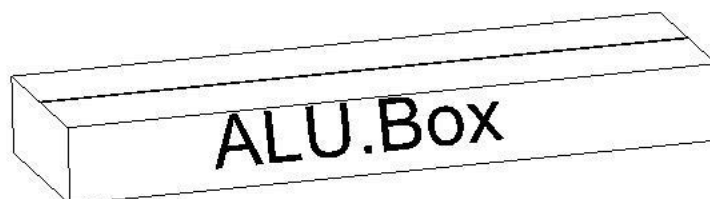





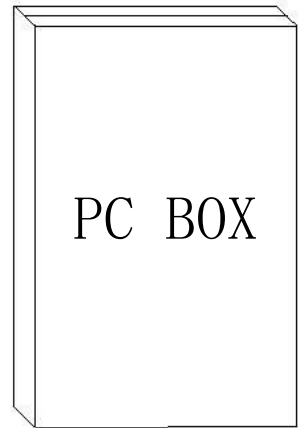

DEL	NR.	ST.
	W01	4
	W02	1
	CX	8
	J01	212
	J02	150
	J03	27 M
	HL	30
	HL2	8
	S01 M6X35	30
	M01	38
	M02	30
	Z01 M6X60	218
	Z02 M4.2X16	246
	Z03 M4.2X25	16
	Z04 Ø6X16	8















# 142-2-7 (papplåda)

DEL	NR.	ST.
<input type="checkbox"/>	Y1	4
<input type="checkbox"/>	Y2	6
<input type="checkbox"/>	Y3	6
<input type="checkbox"/>	Y4	6
<input type="checkbox"/>	Y5	6
<input type="checkbox"/>	Y9	1
<input type="checkbox"/>	Y10	4



DEL	NR.	ST.
	L01A	2
	01-L02A	1
	01-L02B	1
	01-L02G	2
	01-L02H	2
	L04A	4
	L05A	2
	L08A	1
	L09A	2
	L11	8
	K1-1	1

DEL	NR.	ST.
	W01	4
	W02	1
	CX	1
	J01	26
	HL	6
	HL2	8
	S01 M6X35	6
	M01	14
	M02	6
	Z01 M6X60	20
	Z02 M4.2X16	53
	Z03 M4.2X25	2
	Z04 Ø6X16	8







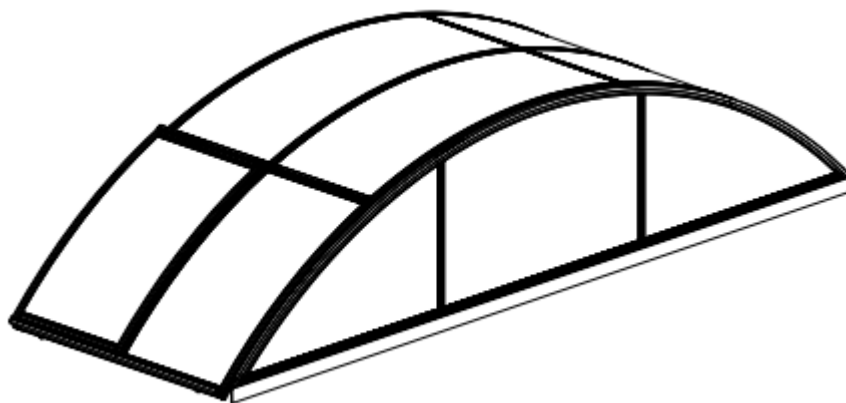

DEL	NR.	ST.
	Y1	4
	Y9	1
	Y10	1

DEL	NR.	ST.
	J03	7,14 M

## Montering av K1

# K1



PART	NO	QTY
	L01A	2
	K1-1	1
	L08A	1
	HL	6
	M02	6
	S01 M6X35	6
	M01	6
	Z01 Ø6X60	4
	Z02 M4.2X16	5

Montera hjulen på L01A (3 st.)  
med S01 & M01.

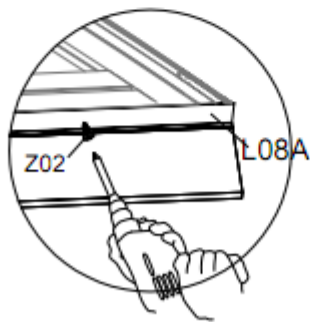
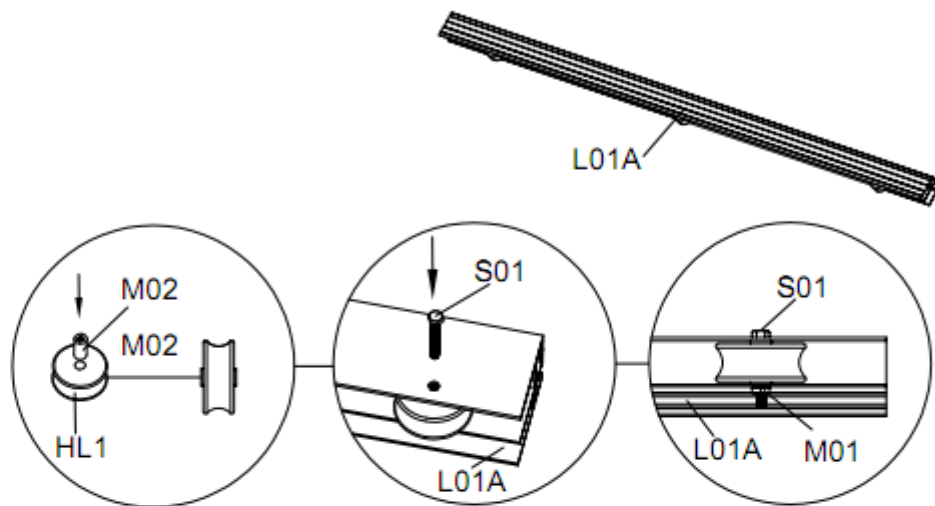



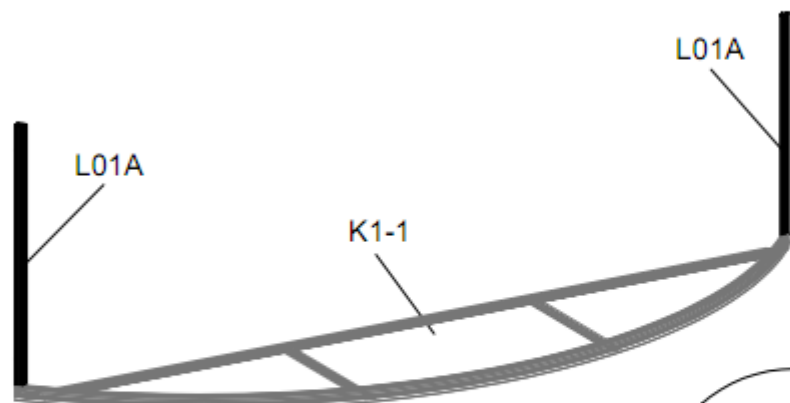

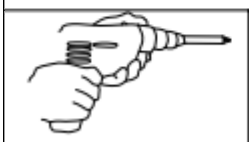
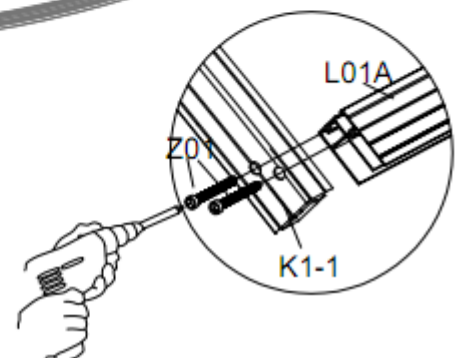

Montera L08A på K1-1 med Z02.



Montera L01A x 2 st. på K1-1 med Z01,  
se bilden ovan.



PART	NO	QTY
	L04A	2
	01-L02B	1
	L11	4
	Y1	2
	Z02	16
	M4.2X16	
	Z01	4
	Ø6X60	

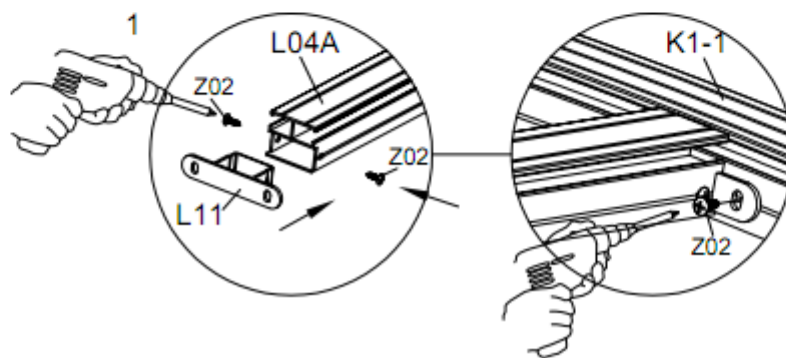
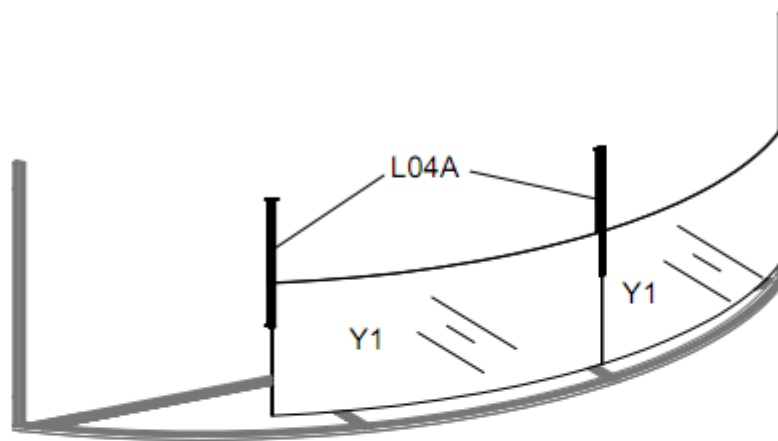





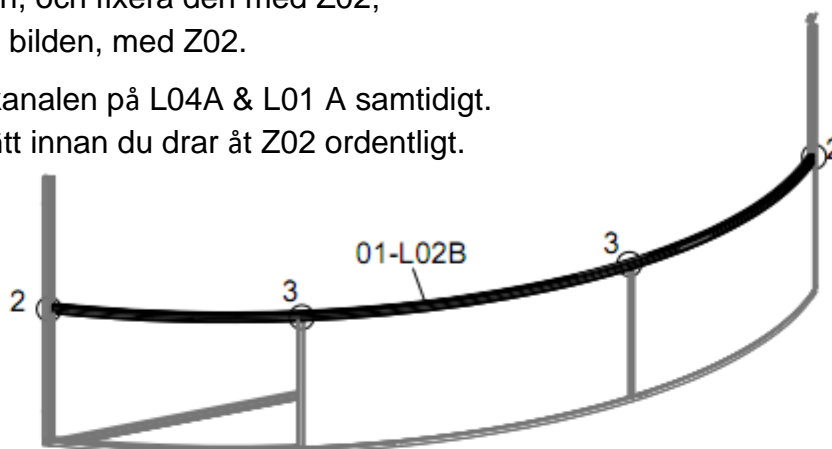



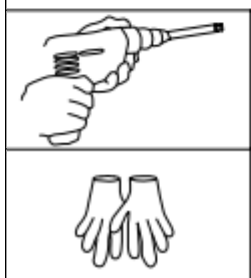
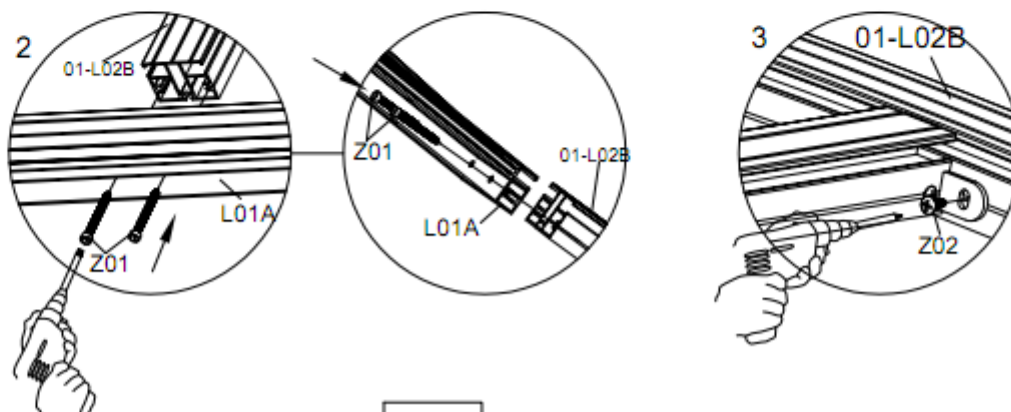



1. För in L11 i L04A, se bilden, och fixera den med Z02;
2. Montera L04A på K1-1, se bilden, med Z02.

Viktigt! Y1 måste placeras i kanalen på L04A & L01 A samtidigt.  
Se till att alla paneler sitter rätt innan du drar åt Z02 ordentligt.



Montera ihop 01-L02B med L01A och L04A,  
använd Z01 & Z02.



PART	NO	QTY
	01-L02A	1
	L04A	2
	L11	4
	Y1	2
	Y9	1
	Z02 M4.2X16	16
	Z01 Ø6X60	4
	HL	2
	M02	2
	S01 M6X35	2
	M01	2

Viktigt! Y1 & Y9 måste placeras i kanalen på L04A/L01A samtidigt.  
Se till att alla paneler sitter rätt innan du drar åt Z02 ordentligt.

PART	NO	QTY
	J03	7.14M

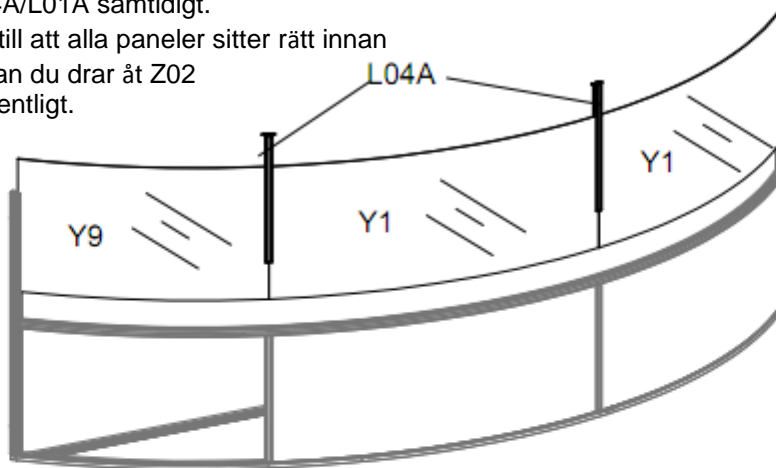

Montera L04A på 01-L02B, se bilden, med Z02.

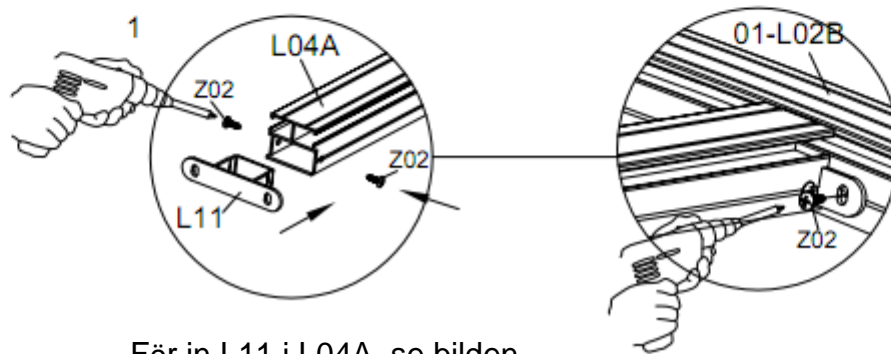

För in L11 i L04A, se bilden, och fixera den på L04A med Z02;

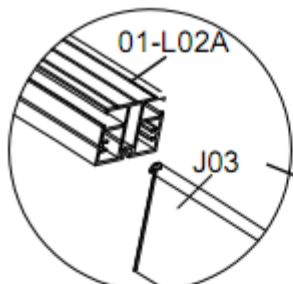



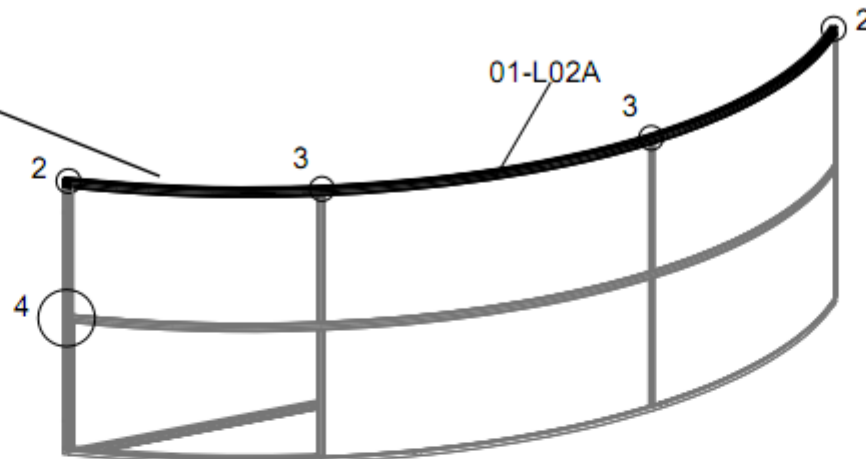
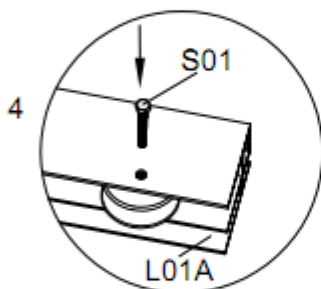

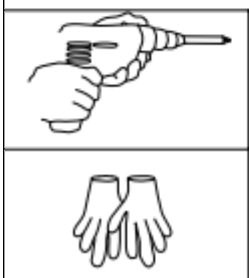
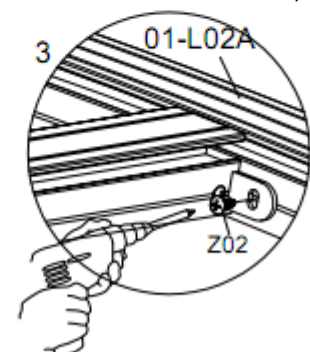
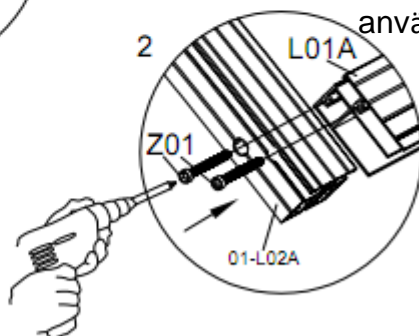

För in gummit J03 i kanalen på 01-L02A.





Montera ihop 01-L02A med L01A och L04A, använd Z01 & Z02.

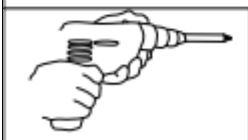
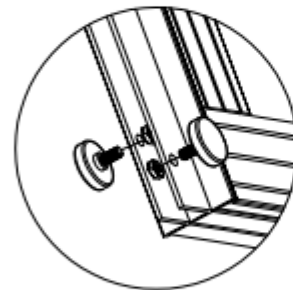
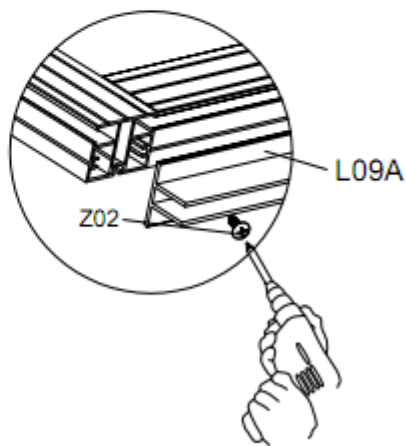
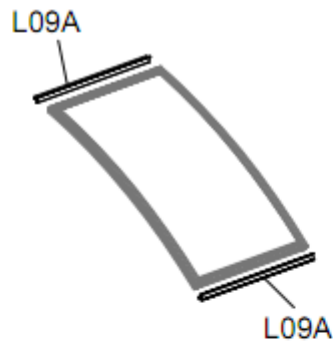
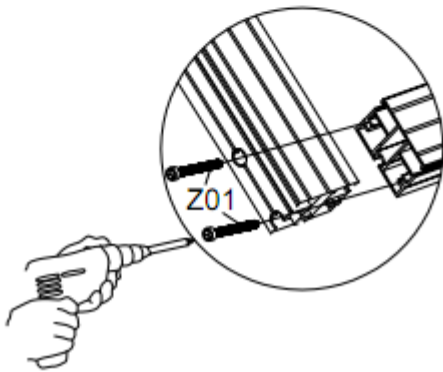
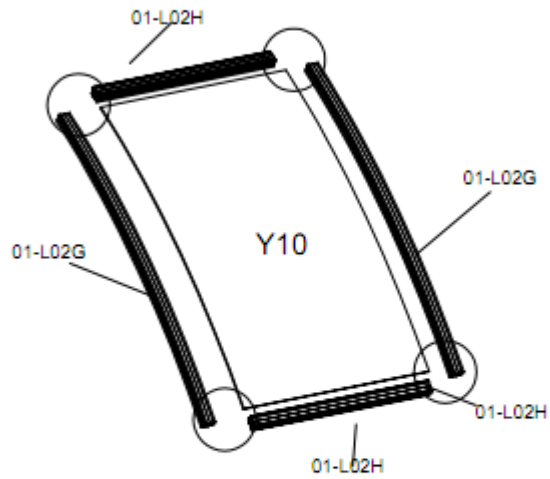

PART	NO	QTY
	01-L02G	2
	01-L02H	2
	L09A	2
	HL2	8
	Y10	1
	Z02 M4.2X16	8
	Z01 Ø6X60	8
	M01	8

## Montering av fönster





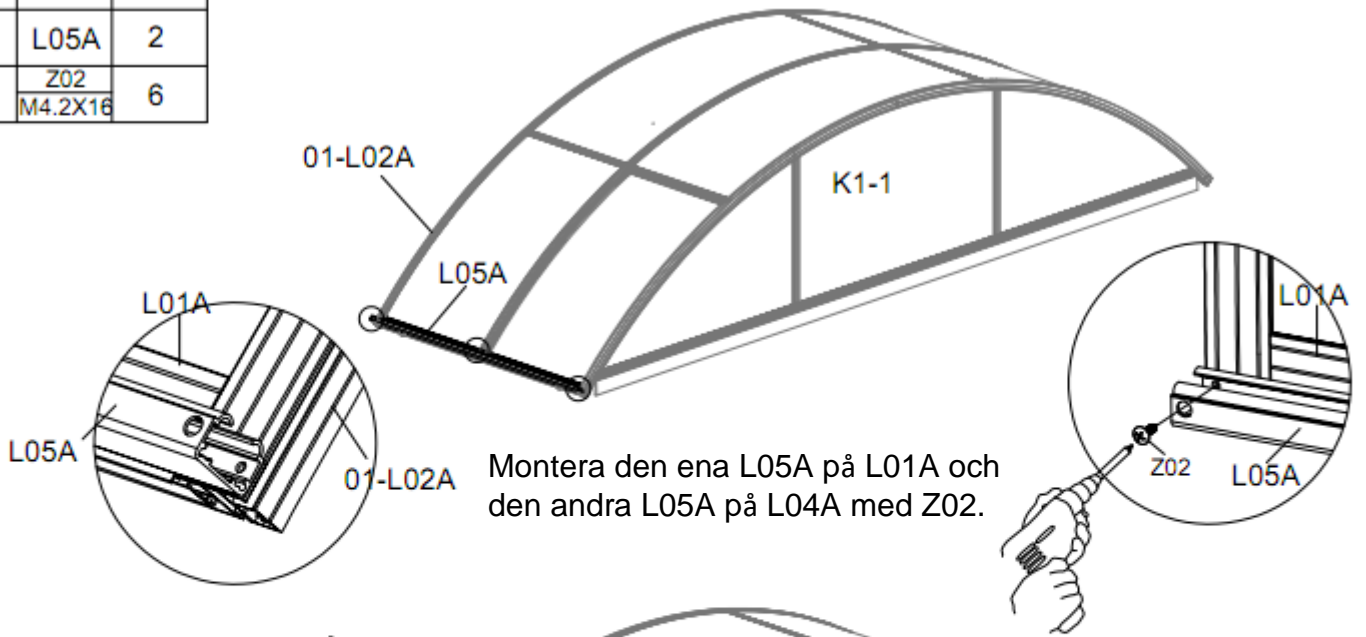

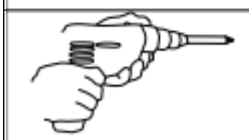
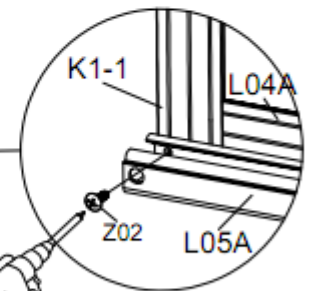
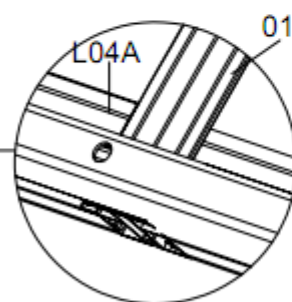
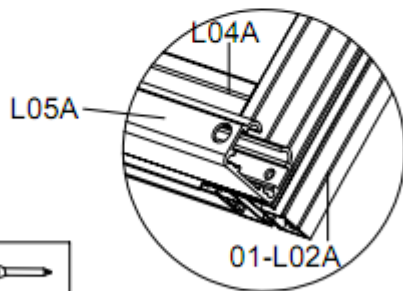
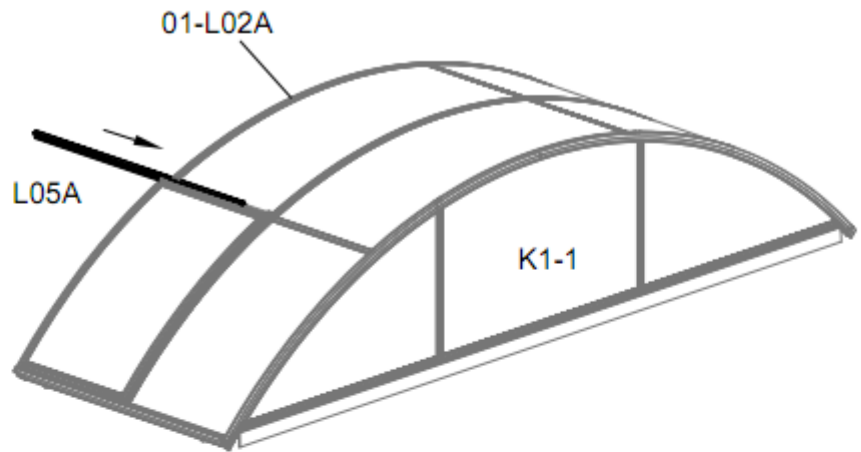
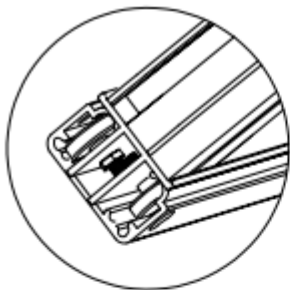
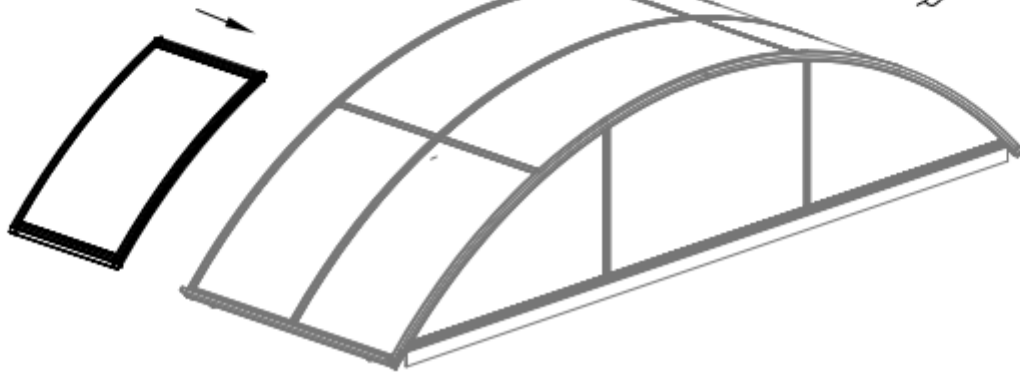

PART	NO	QTY
	L05A	2
	Z02 M4.2X16	6



Montera den ena L05A på L01A och den andra L05A på L04A med Z02.



PART	NO	QTY
	CX	1
	J01	26
	Z02 M4.2X16	2
	Z03 M4.2X25	2
	Z04 Ø6X16	8
	W01	4
	W02	1

Montera W01 (4 st.) på båda ändarna av L05A med Z04.

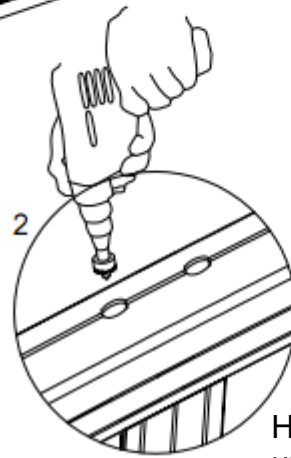
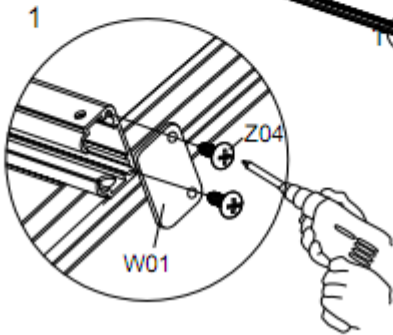
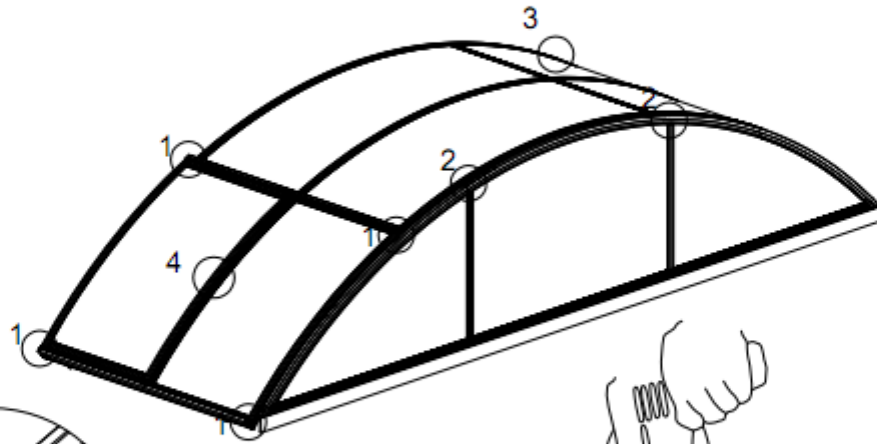

Hålen måste utvidgas till diameter 14 mm, använd en brotsch och en elskruvdragare.

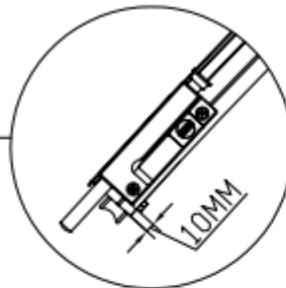
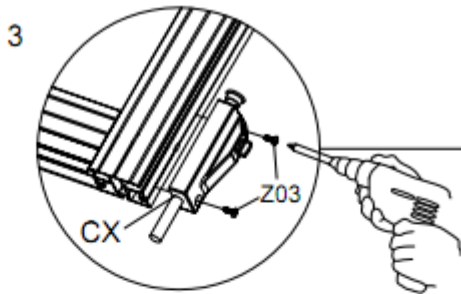

Montera CX på 01-L02A, 10 mm från nederkanten, med Z03.

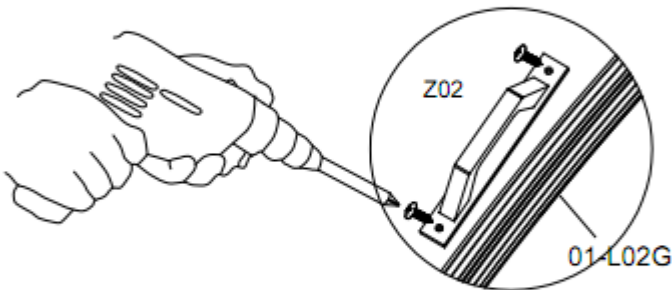



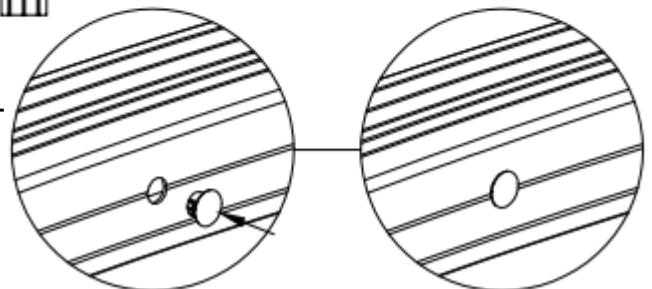



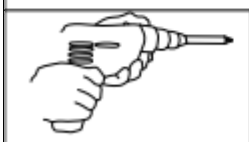





Sätt på handtaget W02 på fönsterprofilen 01-L02G med Z02.





Dölj alla hål med J01



DEL	NR.	ST.
	L01A	2
	02-L02A	2
	02-L02B	1
	L04A	4
	L11	8





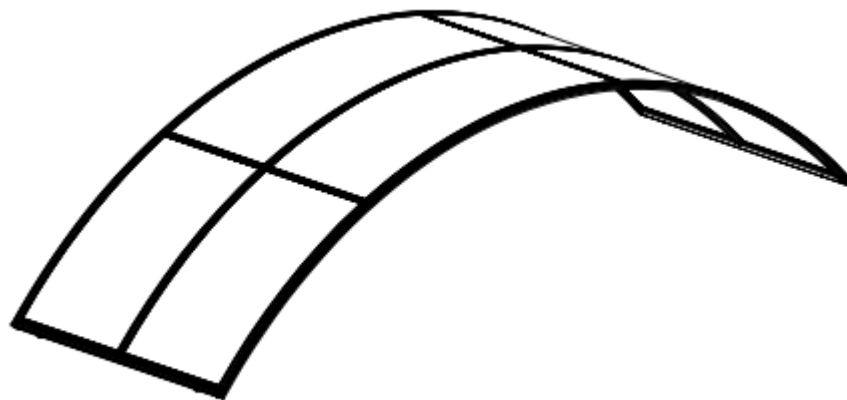

DEL	NR.	ST.
	CX	2
	J01	8
	HL	6
	S01 M6X35	6
	M01	6
	M02	6
	Z01 M6X60	12
	Z02 M4.2X16	32
	Z03 M4.2X25	4

DEL	NR.	ST.
	Y2	6

DEL	NR.	ST.
	J03	6,82 M

K2



PART	NO	QTY
	L01A	2
	02-L02A	1
	HL	6
	M02	6
	S01 M6X35	6
	M01	6
	Z01 M6X60	4

Montera hjulen på L01A (3 st.)  
med S01 & M01.

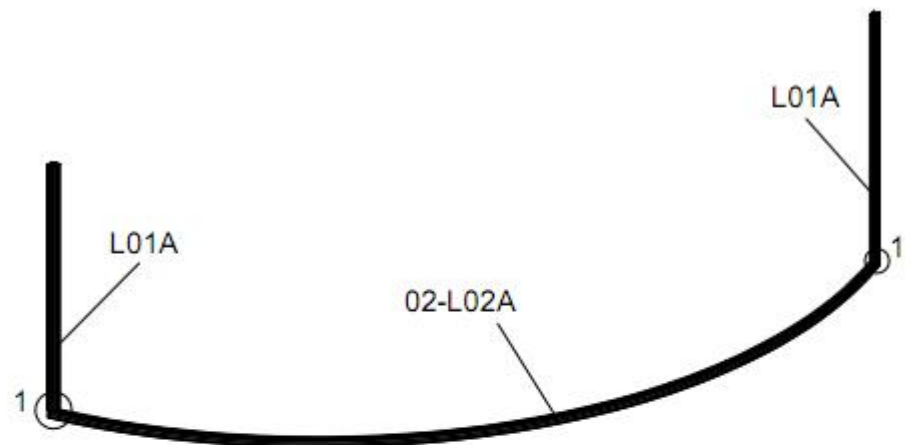
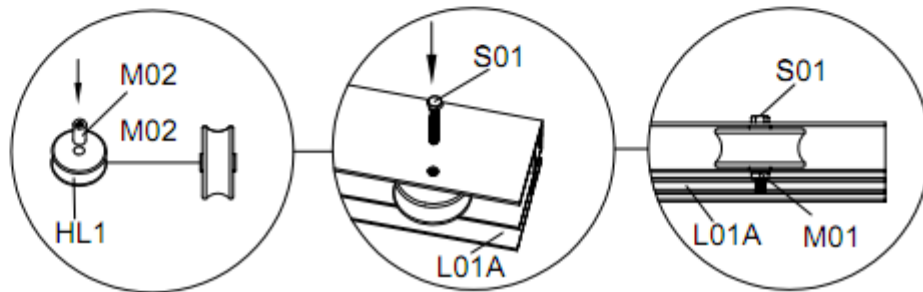
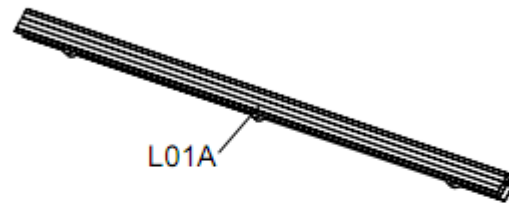

Montera L01A x 2 st. på 02-L02A med Z01.

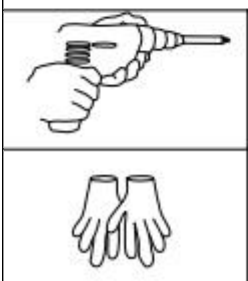
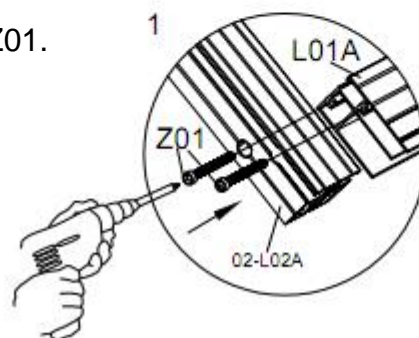





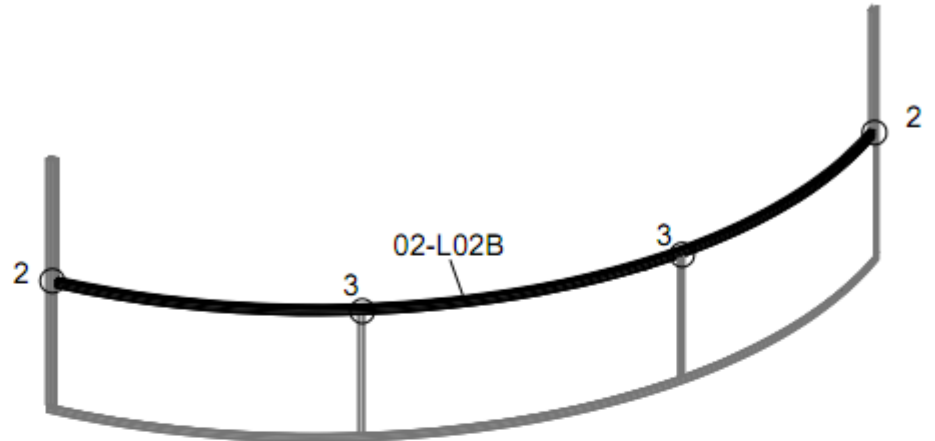
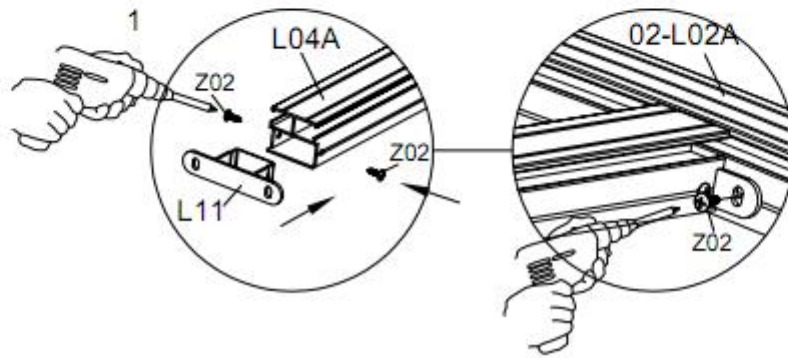
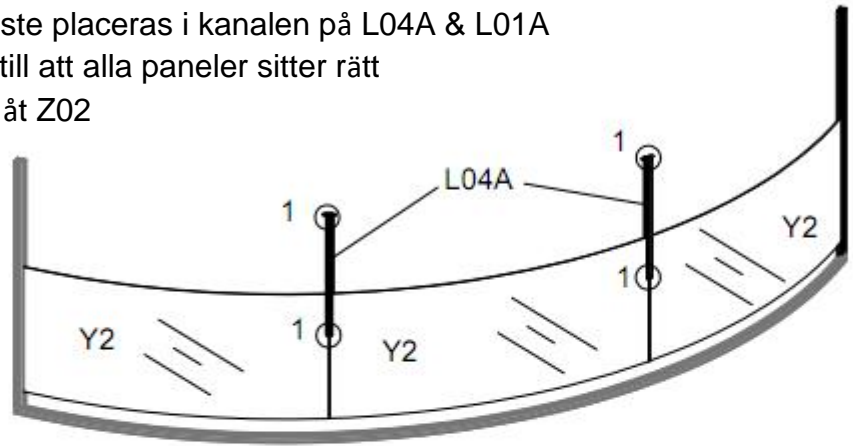

PART	NO	QTY
	L04A	2
	02-L02B	1
	L11	4
	Y2	3
	Z02	16
	Z01 M6X60	4

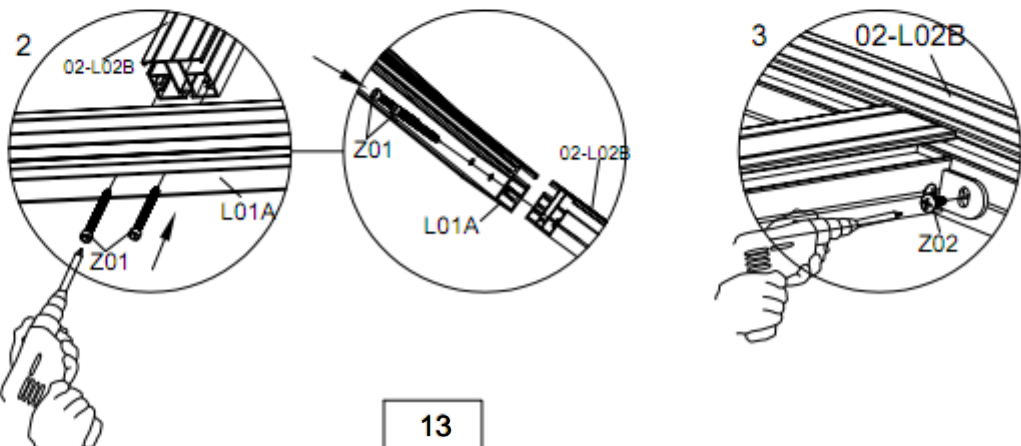
1. För in L11 i L04A, se bilden, och fixera den med Z02;
  2. Montera L04A på 02- L02A, se bilden, med Z02.
- Viktigt! Y2 måste placeras i kanalen på L04A & L01A samtidigt. Se till att alla paneler sitter rätt innan du drar åt Z02 ordentligt.





Montera ihop 02-L02B med L01A och L04A, använd Z01 & Z02.

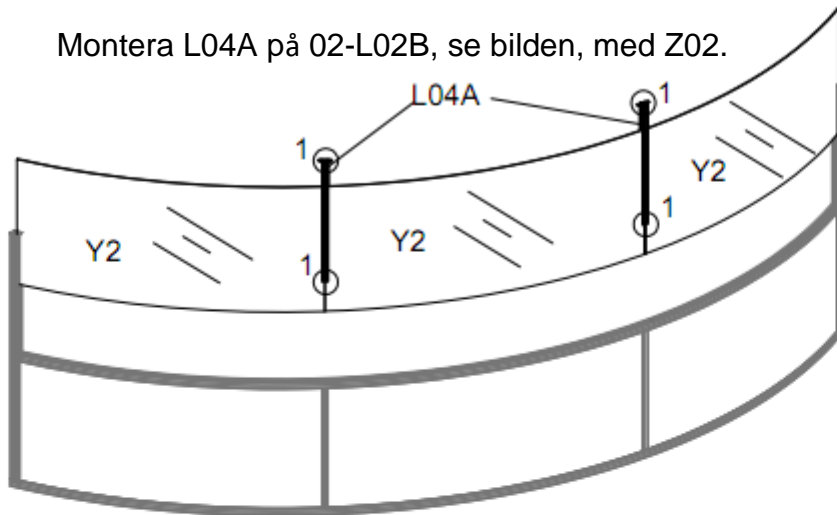

PART	NO	QTY
	02-L02A	1
	L04A	2
	L11	4
	Y2	3
	Z02	16
	Z01 M6X60	4

Montera L04A på 02-L02B, se bilden, med Z02.



PART	NO	QTY
	J03	6.82M

Viktigt!  
Y2 måste placeras i kanalen på L04A/L01A samtidigt. Se till att alla panelerna sitter på rätt position innan du drar åt Z02 ordentligt.

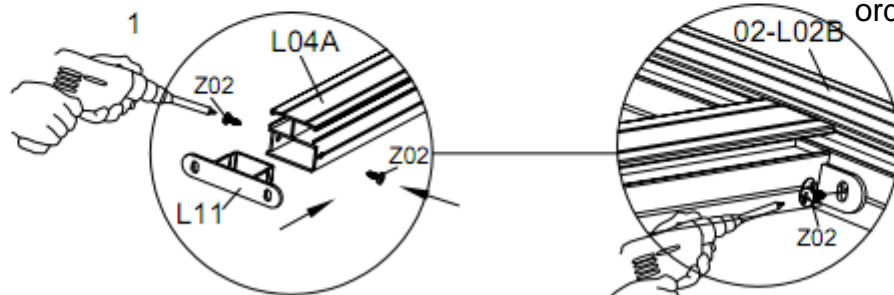



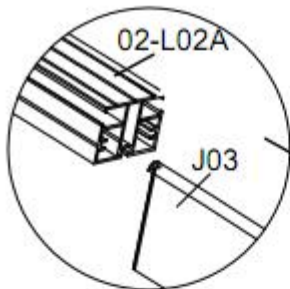

För in L11 i L04A, se bilden, och fixera den på L04A med Z02;

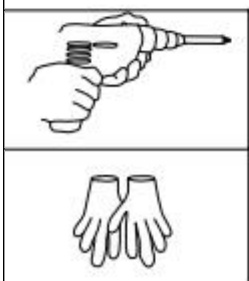
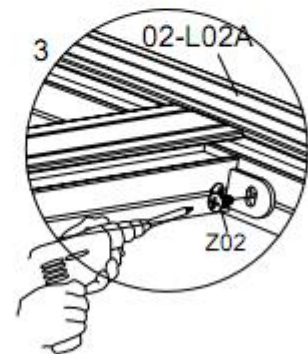
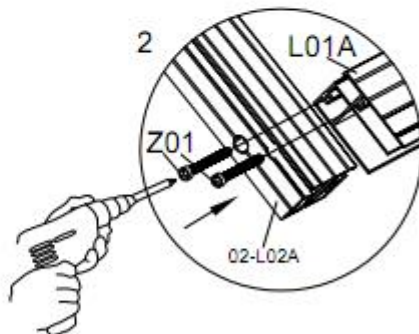
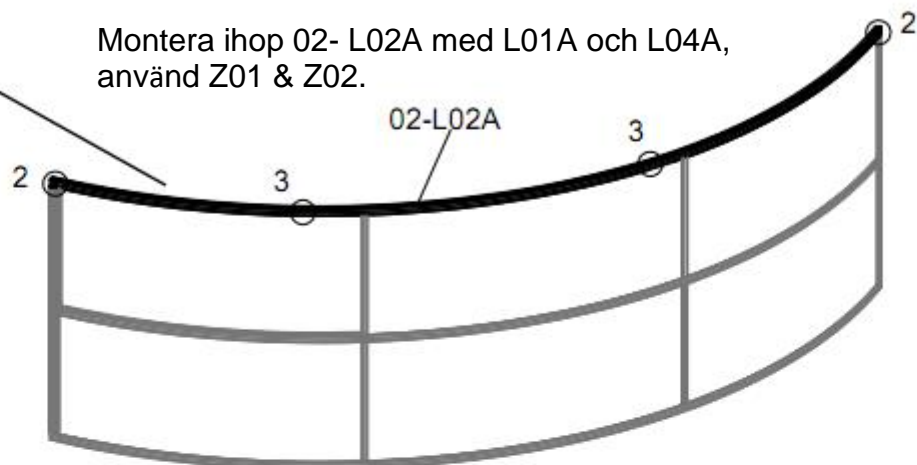

För in gummit J03 i kanalen på 02-L02A.

Montera ihop 02-L02A med L01A och L04A, använd Z01 & Z02.



PART	NO	QTY
	CX	2
	J01	8
	Z03 M4.2X25	4

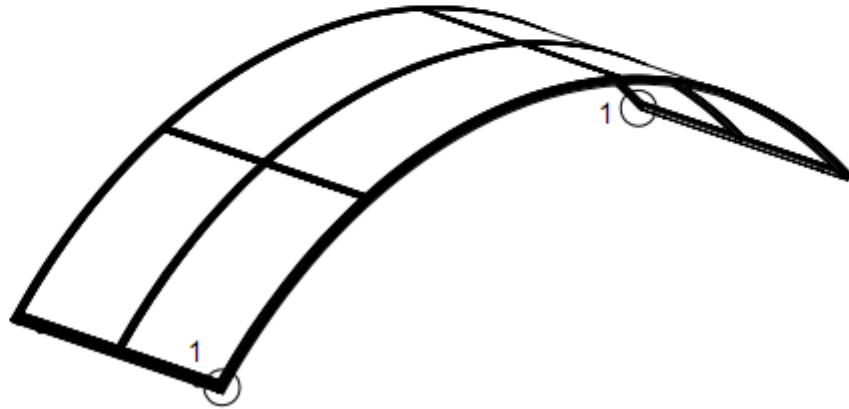



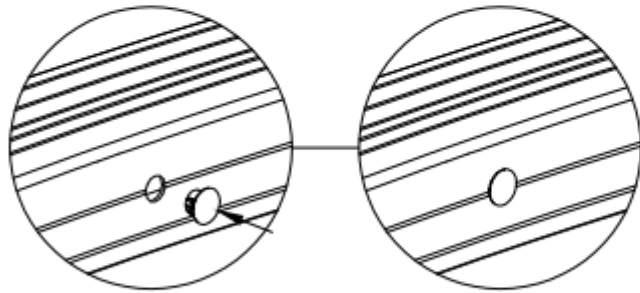
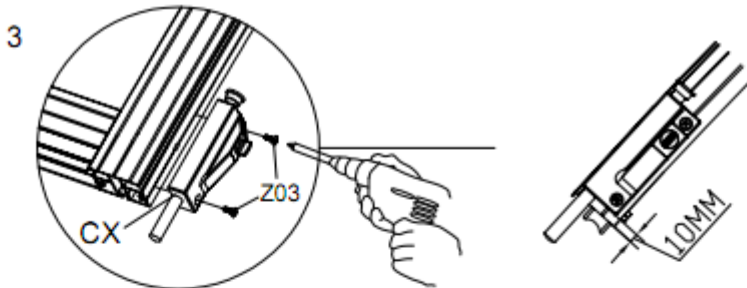



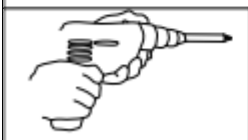







Montera CX (2 st.) på 02-L02A, 10 mm från nederkanten, med Z03.





Dölj alla hål med J01



DEL	NR.	ST.
	L01A	2
	03-L02A	2
	03-L02B	1
	L04A	4
	L11	8





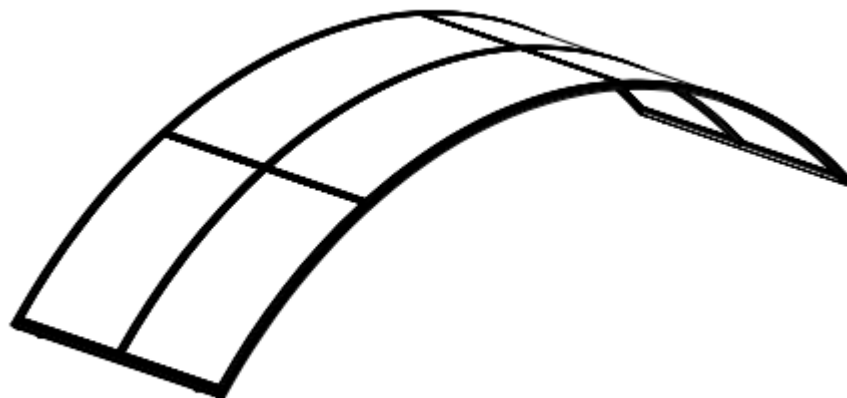

DEL	NR.	ST.
	CX	2
	J01	8
	HL	6
	S01 M6X35	6
	M01	6
	M02	6
	Z01 M6X60	12
	Z02 M4.2X16	32
	Z03 M4.2X25	4

DEL	NR.	ST.
	Y3	6

DEL	NR.	ST.
	J03	6,5 M

# K3







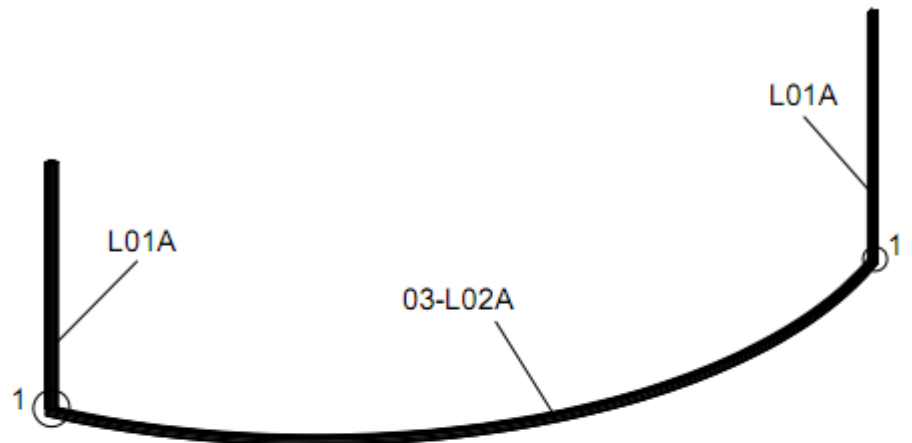
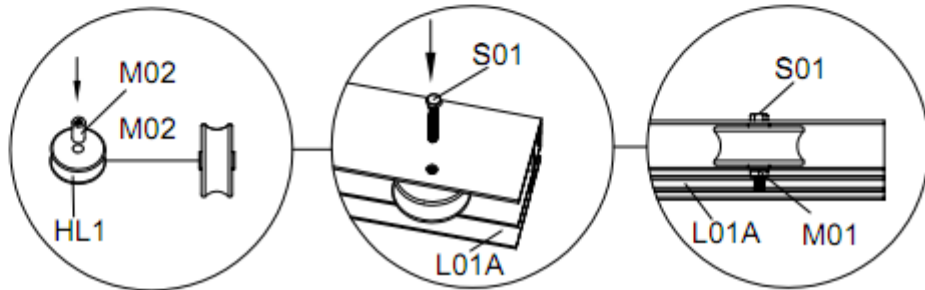
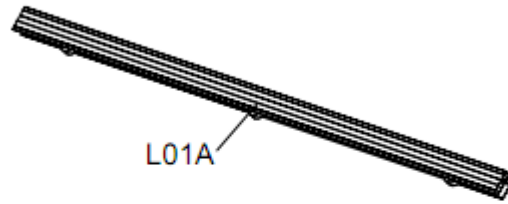

PART	NO	QTY
	L01A	2
	03-L02A	1
	HL	6
	M02	6
	S01	6
	M6X35	
	M01	6
	Z01	4
	M6X60	

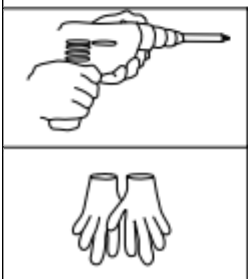
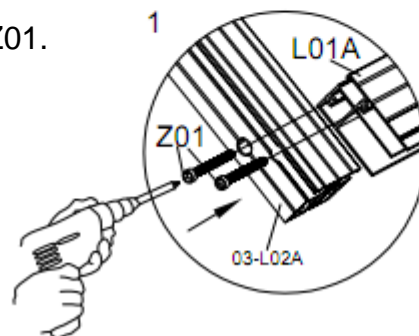
Montera hjulen på L01A (3 st.) med S01 & M01.



Montera L01A x 2 st. på 03-L02A med Z01.







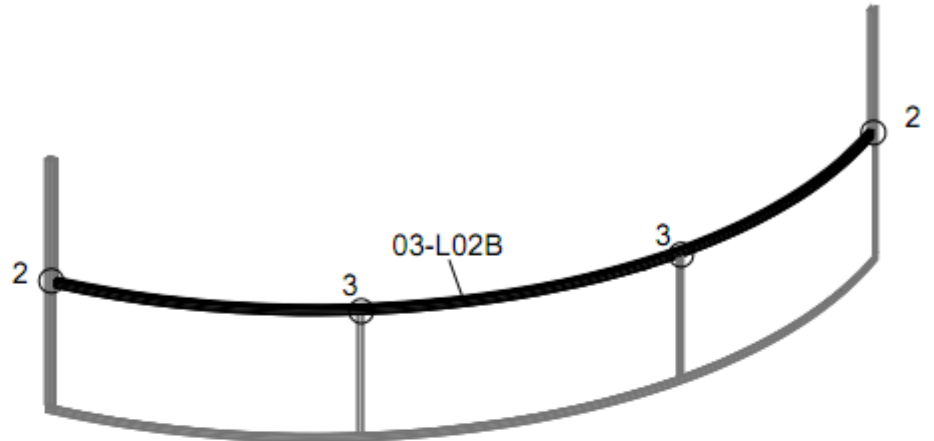
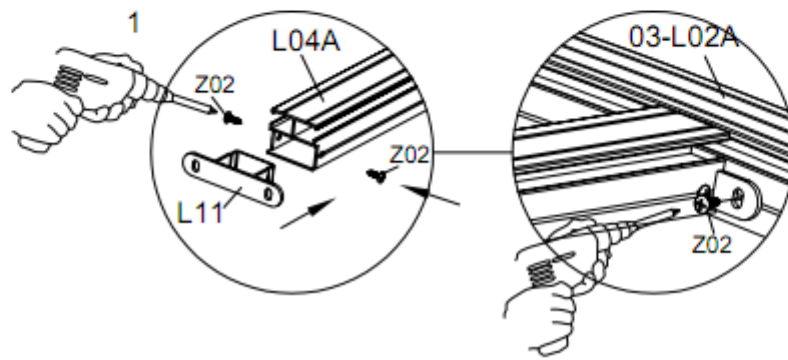
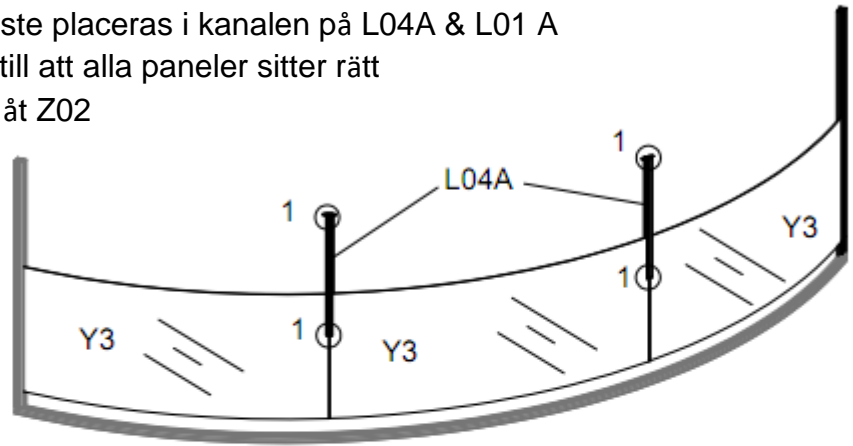

PART	NO	QTY
	L04A	2
	03-L02B	1
	L11	4
	Y3	3
	Z02	16
	Z01 M6X60	4

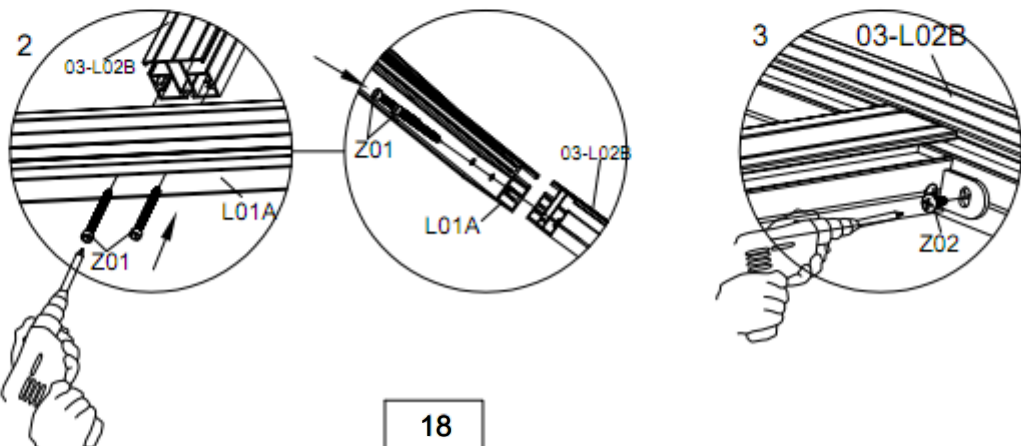
1. För in L11 i L04A, se bilden, och fixera den med Z02;
  2. Montera L04A på 03-L02A, se bilden, med Z02.
- Viktigt! Y3 måste placeras i kanalen på L04A & L01 A samtidigt. Se till att alla paneler sitter rätt innan du drar åt Z02 ordentligt.





Montera ihop 03-L02B med L01A och L04A, använd Z01 & Z02.

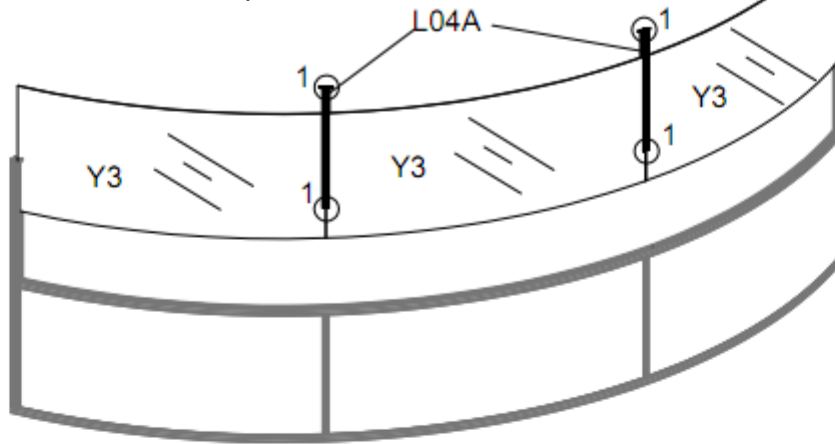

PART	NO	QTY
	03-L02A	1
	L04A	2
	L11	4
	Y3	3
	Z02	16
	Z01 M6X60	4

Montera L04A på 03-L02B, se bilden, med Z02.



PART	NO	QTY
	J03	6.5M

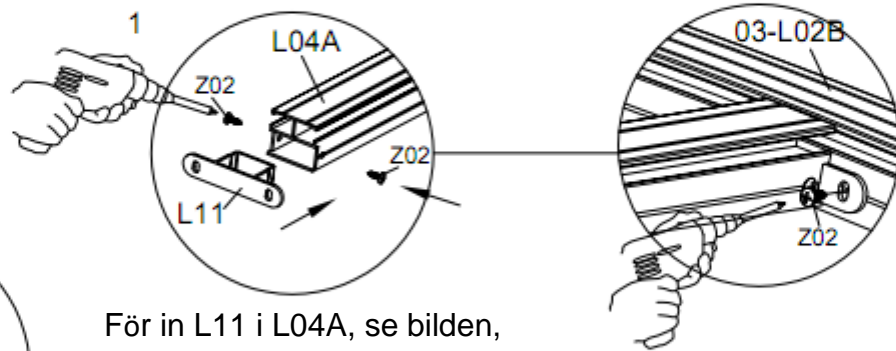

För in L11 i L04A, se bilden, och fixera den på L04A med Z02;

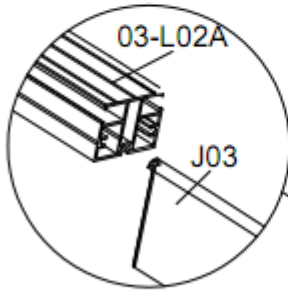

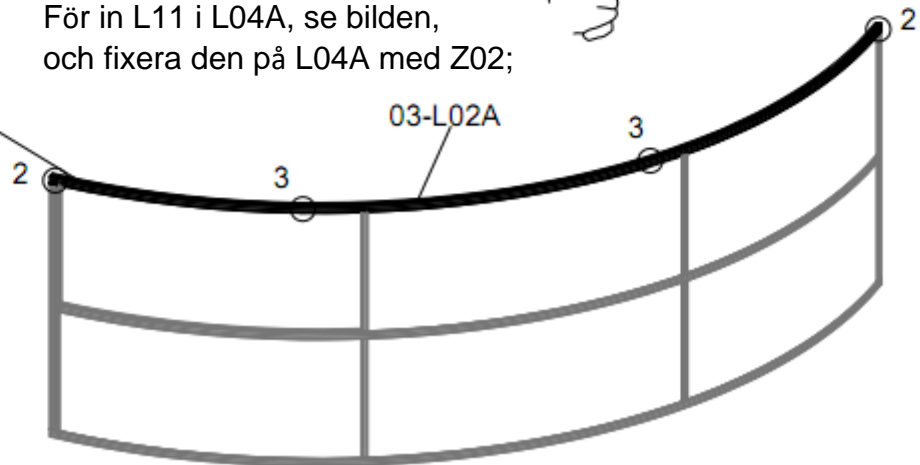

För in gummit J03 i kanalen på 03-L02A.

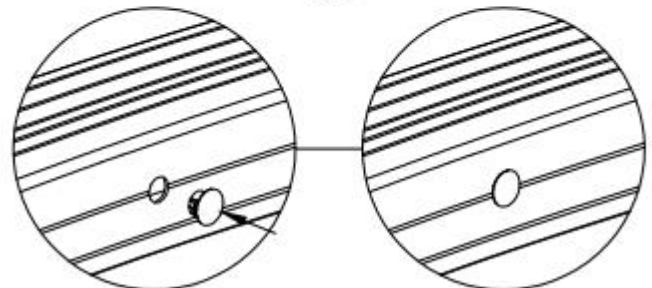
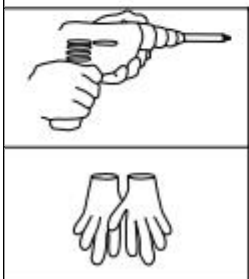
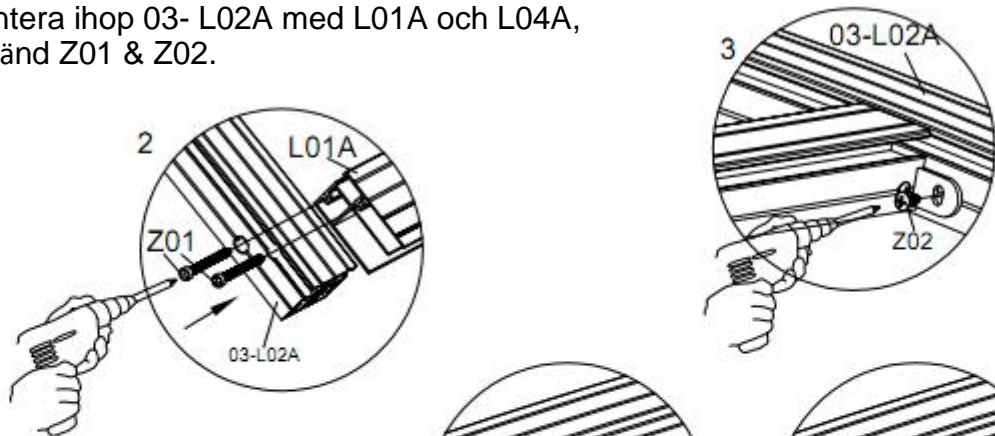

Montera ihop 03-L02A med L01A och L04A, använd Z01 & Z02.



Dölj alla hål med J01

PART	NO	QTY
	CX	2
	J01	8
	Z03 M4.2X25	4

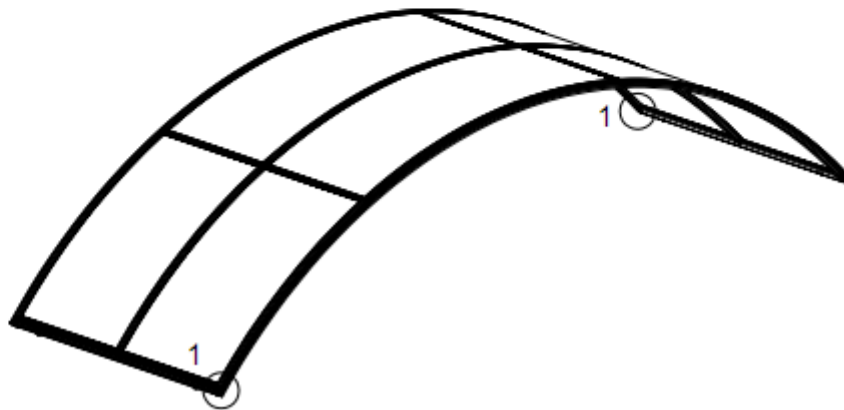



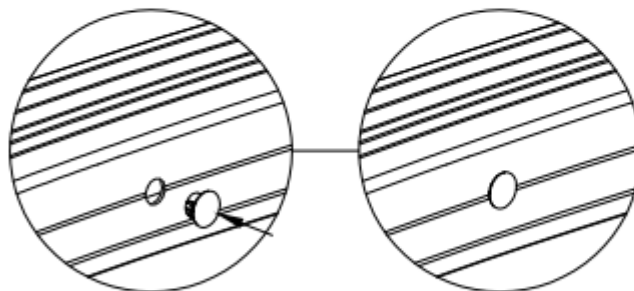
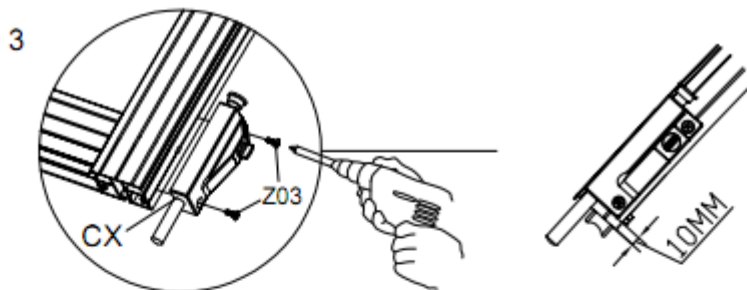



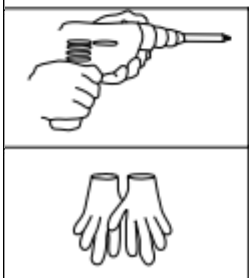







Montera CX (2 st.) på 03-L02A, 10 mm från nederkanten, med Z03.





Dölj alla hål med J01



DEL	NR.	ST.
	L01A	2
	04-L02A	2
	04-L02B	1
	L04A	4
	L11	8





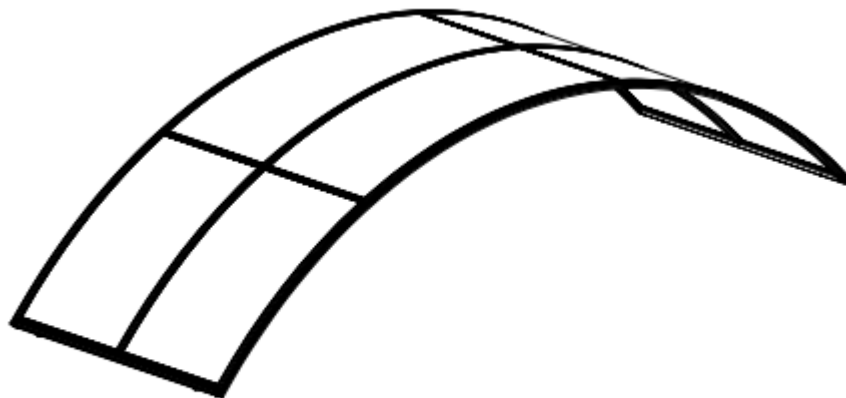

DEL	NR.	ST.
	CX	2
	J01	8
	HL	6
	S01 M6X35	6
	M01	6
	M02	6
	Z01 M6X60	12
	Z02	32
	Z03 M4.2X25	4

DEL	NR.	ST.
	Y4	6

DEL	NR.	ST.
	J03	6,18 M

# K4







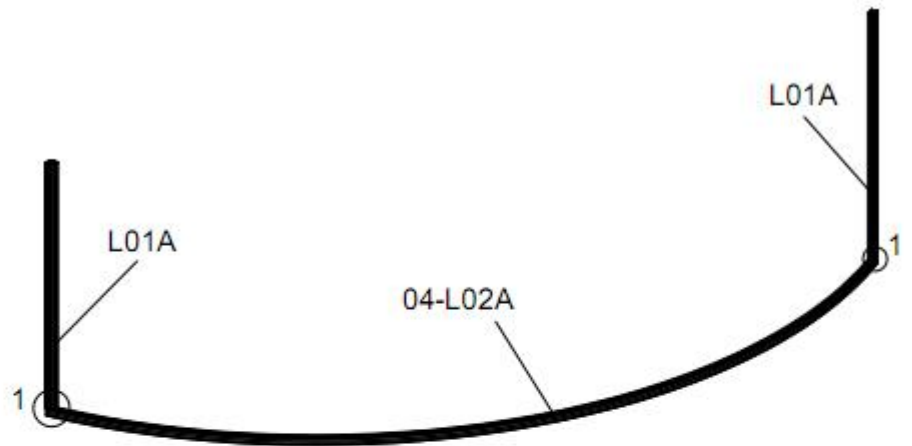
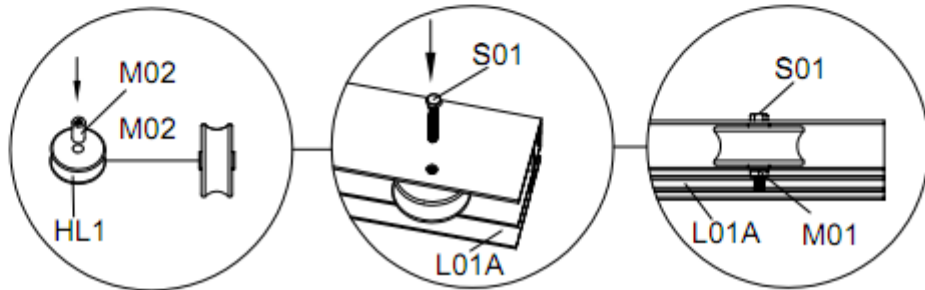
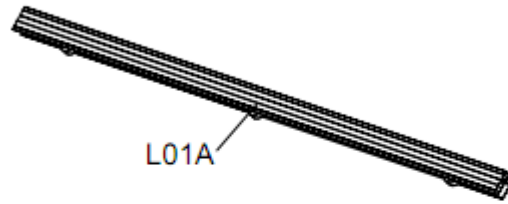

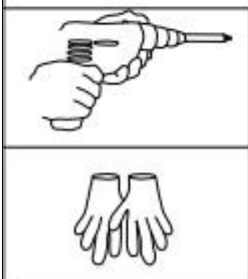
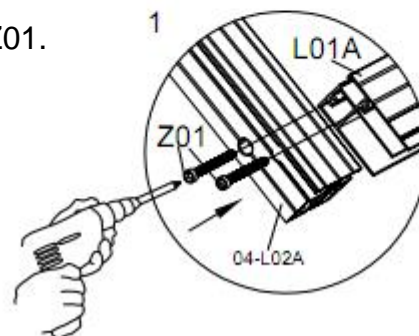

PART	NO	QTY
	L01A	2
	04-L02A	1
	HL	6
	M02	6
	S01	6
	M6X35	
	M01	6
	Z01	4
	M6X60	

Montera hjulen på L01A (3 st.) med S01 & M01.



Montera L01A x 2 st. på 04-L02A med Z01.







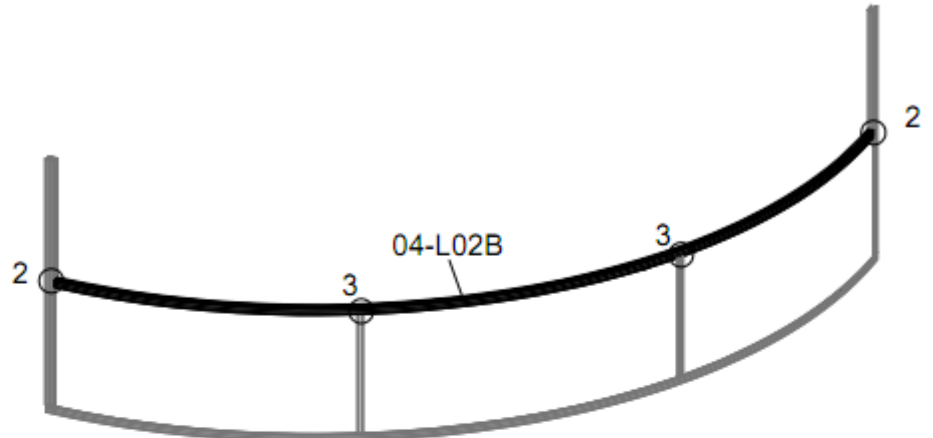
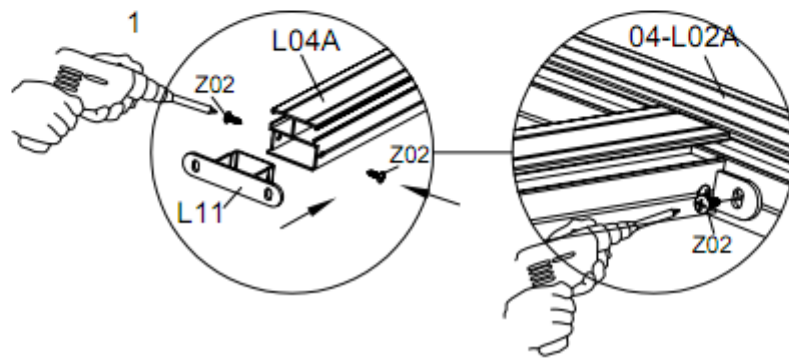
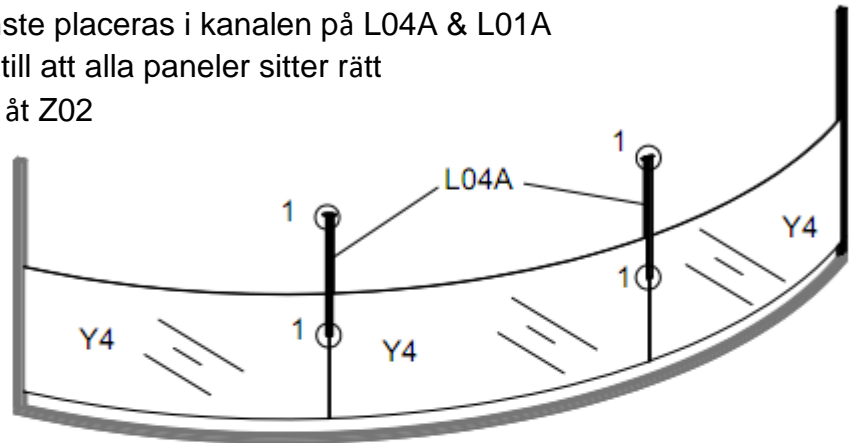

PART	NO	QTY
	L04A	2
	04-L02B	1
	L11	4
	Y4	3
	Z02	16
	Z01	4
	M6X60	4

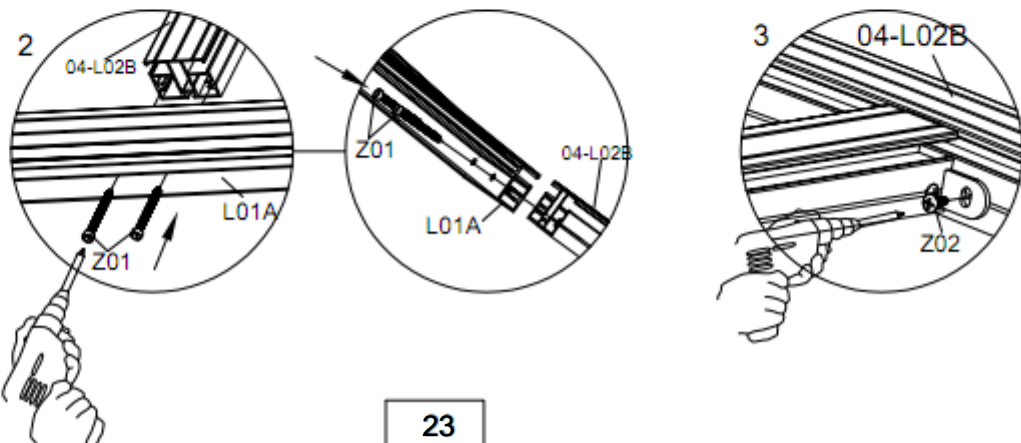
1. För in L11 i L04A, se bilden, och fixera den med Z02;
  2. Montera L04A på 04- L02A, se bilden, med Z02.
- Viktigt! Y4 måste placeras i kanalen på L04A & L01A samtidigt. Se till att alla paneler sitter rätt innan du drar åt Z02 ordentligt.





Montera ihop 04-L02B med L01A och L04A, använd Z01 & Z02.

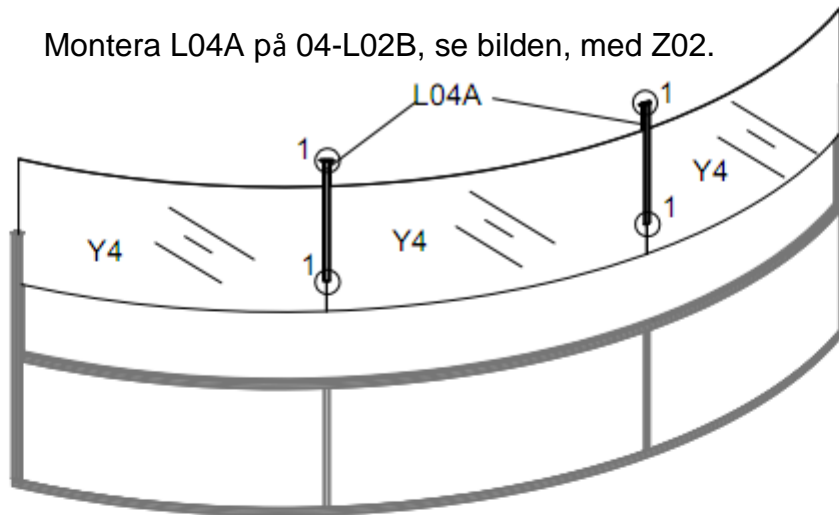

PART	NO	QTY
	04-L02A	1
	L04A	2
	L11	4
	Y4	3
	Z02	16
	Z01 M6X60	4

Montera L04A på 04-L02B, se bilden, med Z02.



PART	NO	QTY
	J03	6.18M

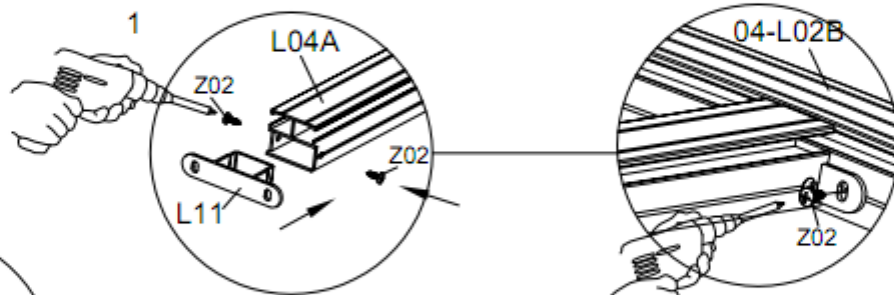

För in L11 i L04A, se bilden, och fixera den på L04A med Z02;

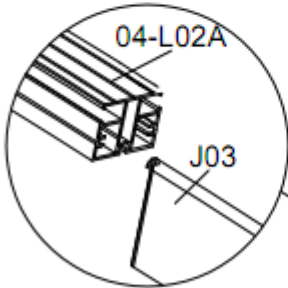

För in gummit J03 i kanalen på 04-L02A.

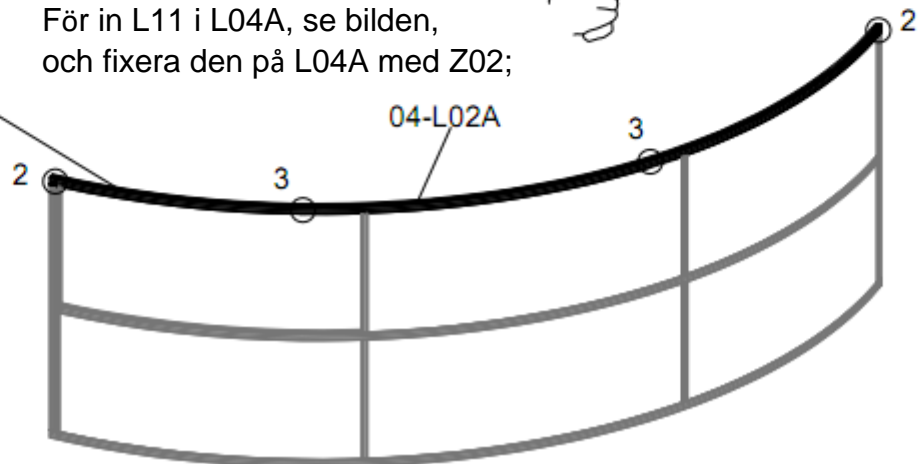

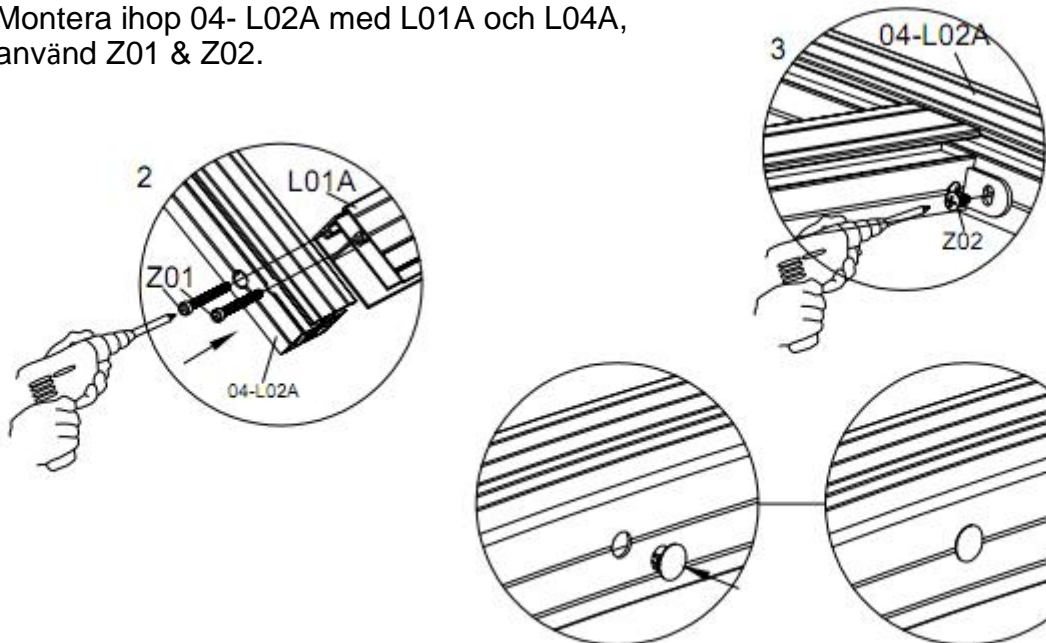

Montera ihop 04-L02A med L01A och L04A, använd Z01 & Z02.

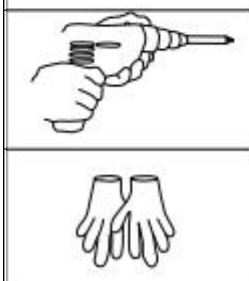

Dölj alla hål med J01



PART	NO	QTY
	CX	2
	J01	8
	Z03 M4.2X25	4

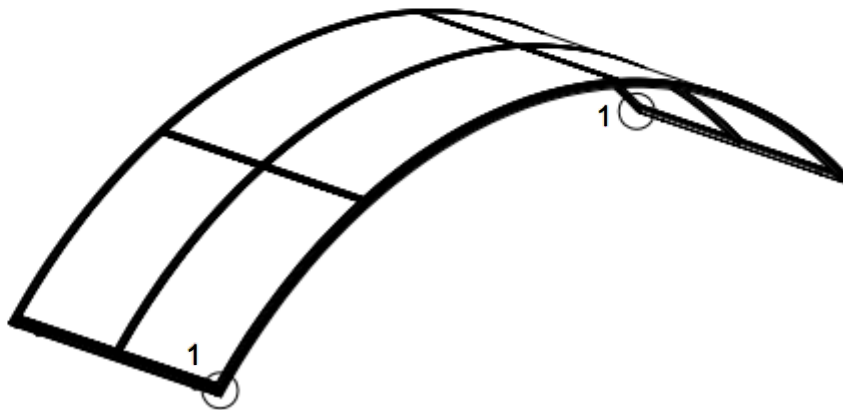



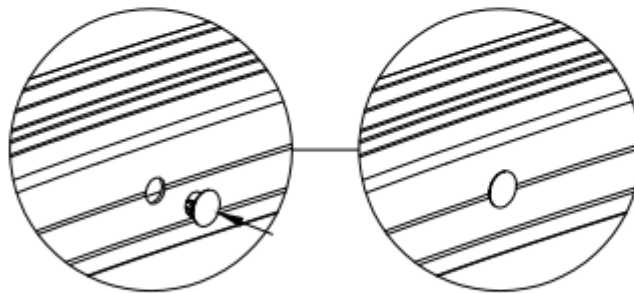
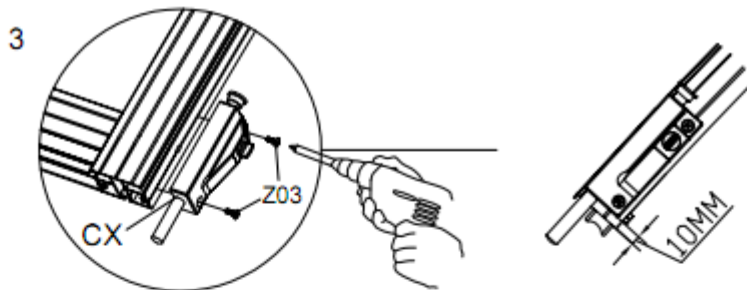



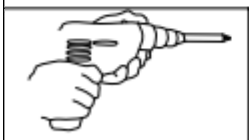









Montera CX (2 st.) på 04-L02A, 10 mm från nederkanten, med Z03.



Dölj alla hål med J01











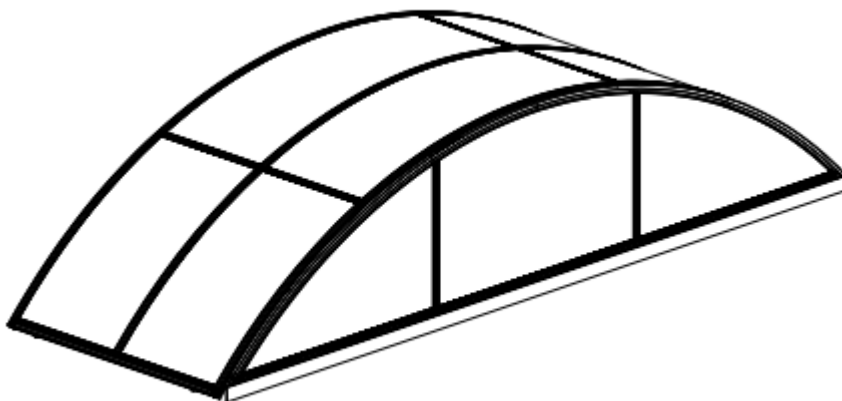

DEL	NR.	ST.
	L01A	2
	05-L02A	1
	05-L02B	1
	L04A	4
	L08B	1
	L11	8
	K5-1	1

DEL	NR.	ST.
	CX	1
	J01	12
	HL	6
	S01 M6X35	6
	M01	6
	M02	6
	Z01 M6X60	12
	Z02 M4X16	37
	Z03 M4.2X25	2

DEL	NR.	ST.
	Y5	6

# K5



PART	NO	QTY
	L01A	2
	K5-1	1
	L08B	1
	HL	6
	M02	6
	S01 M6X35	6
	M01	6
	Z01 Ø6X60	4
	Z02 M4.2X16	5

Montera hjulen på L01A (3 st.)  
med S01 & M01.

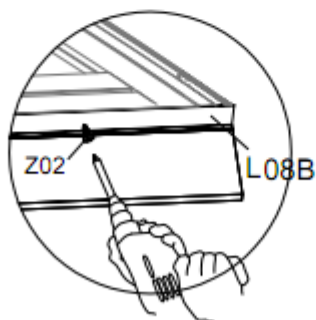
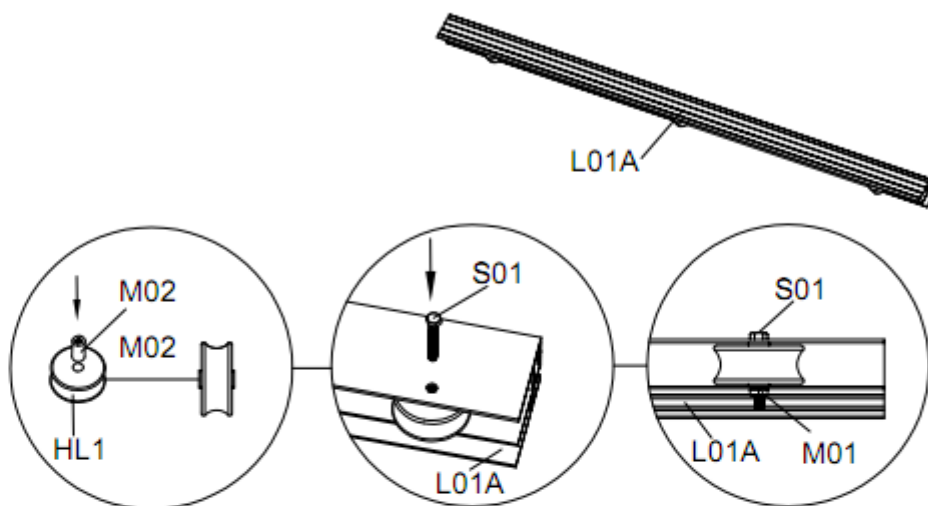



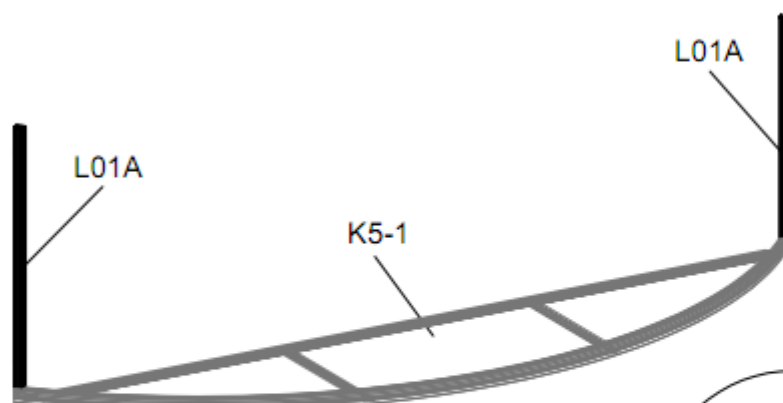

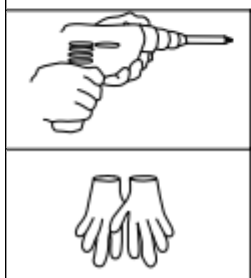
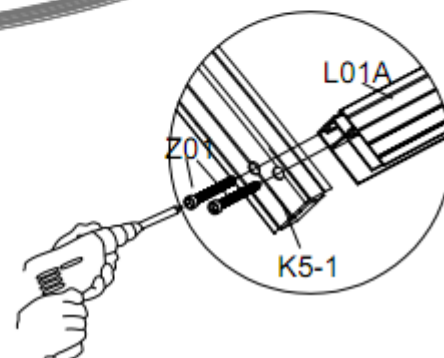

Montera L08B på K5-1 med Z02.



Montera L01A x 2 st. på K5-1 med Z01.



PART	NO	QTY
	L04A	2
	05-L02B	1
	L11	4
	Y5	3
	Z02 M4X16	16
	Z01 M6X60	
	Z01 M6X60	4

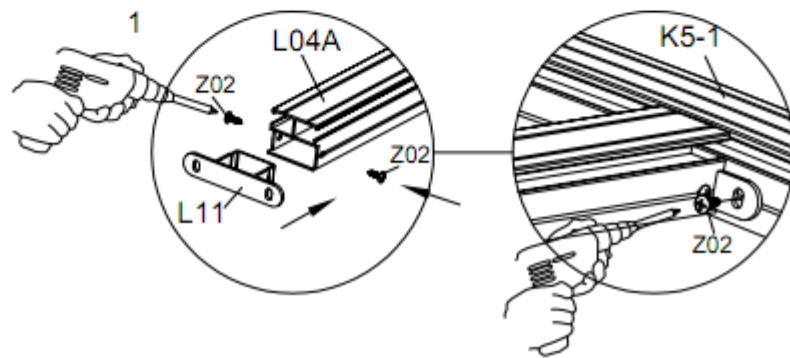
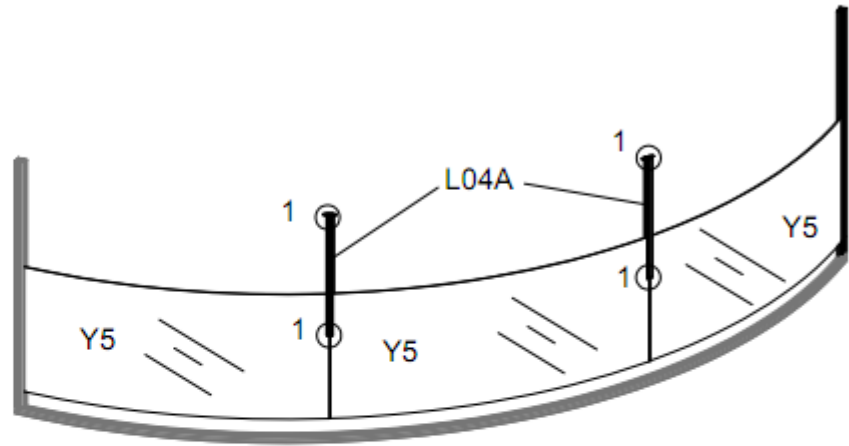



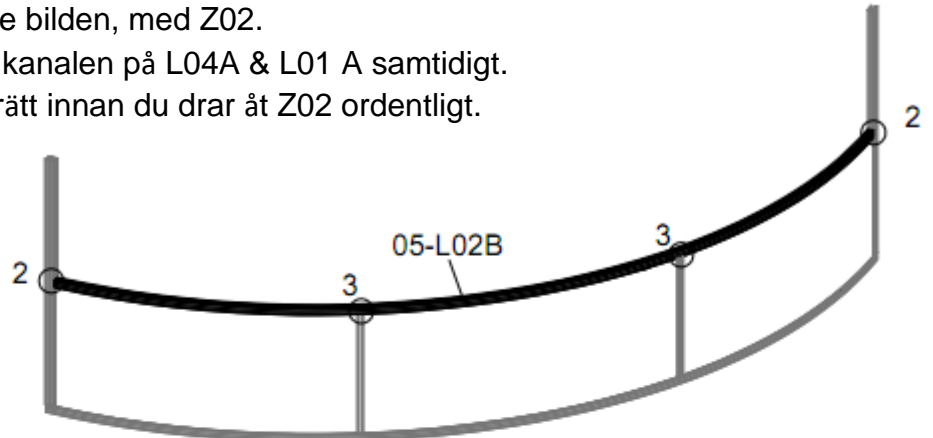

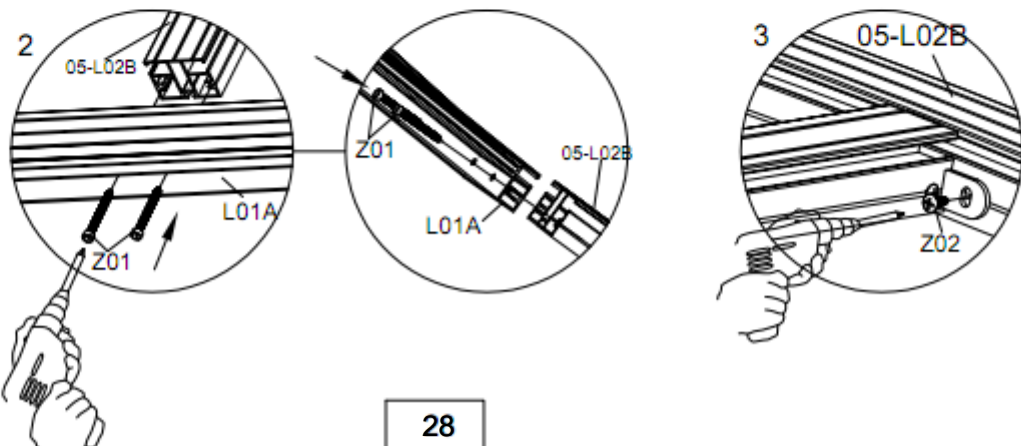

1. För in L11 i L04A, se bilden, och fixera den med Z02;
  2. Montera L04A på K5-1, se bilden, med Z02.
- Viktigt! Y4 måste placeras i kanalen på L04A & L01 A samtidigt.  
Se till att alla paneler sitter rätt innan du drar åt Z02 ordentligt.



Montera ihop 05-L02B med L01A och L04A,  
använd Z01 & Z02.



PART	NO	QTY
	05-L02A	1
	L04A	2
	L11	4
	Y5	3
	Z02	16
	M4X16	
	Z01	4
	M6X60	

Montera L04A på 05-L02B, se bilden, med Z02.

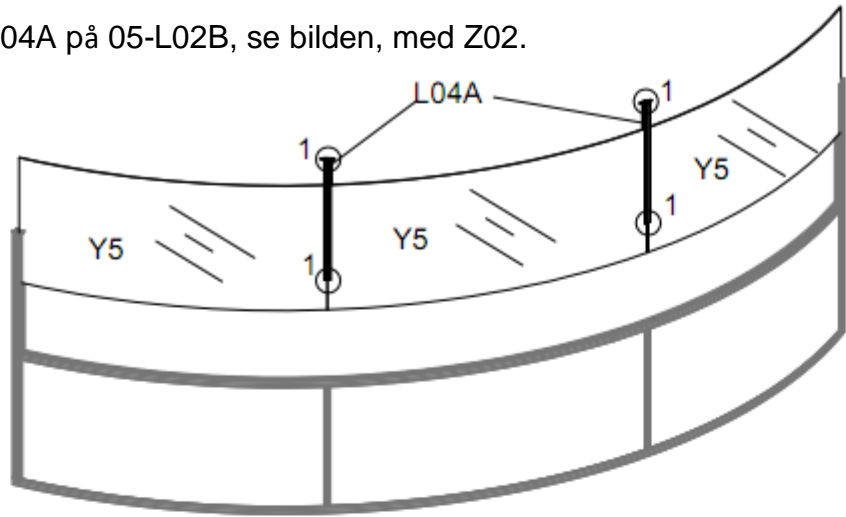

Viktigt!

Y4 måste placeras i kanalen

på L04A/L01A

samtidigt.

Se till att alla

panelerna sitter på

rätt position innan

innan du drar åt Z02

ordentligt.

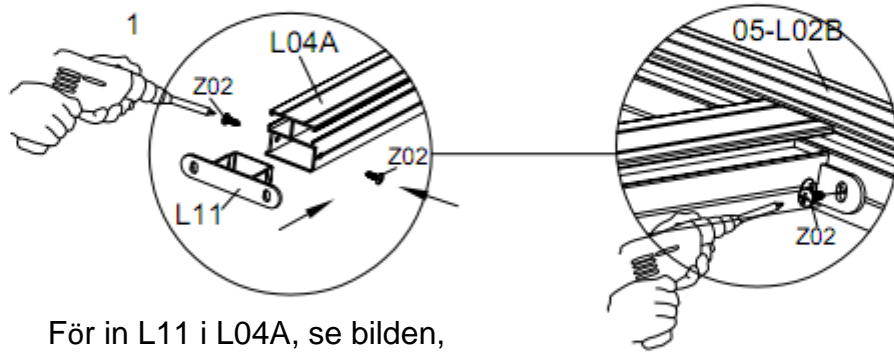

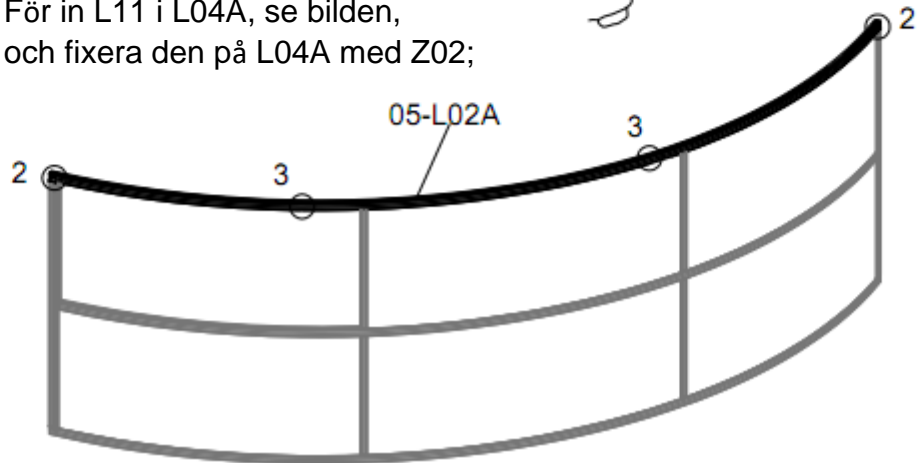

För in L11 i L04A, se bilden, och fixera den på L04A med Z02;

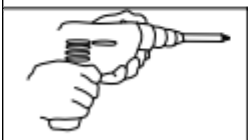
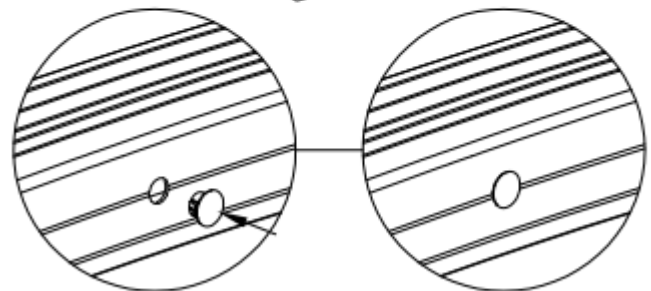
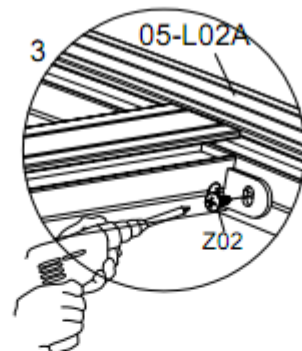
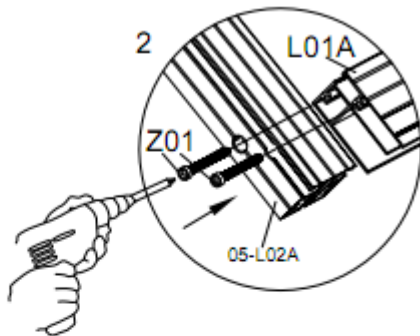

Montera ihop 05-L02A med L01A och L04A, använd Z01 & Z02.



Dölj alla hål med J01

PART	NO	QTY
	CX	1
	J01	12
	Z03 M4.2X25	2

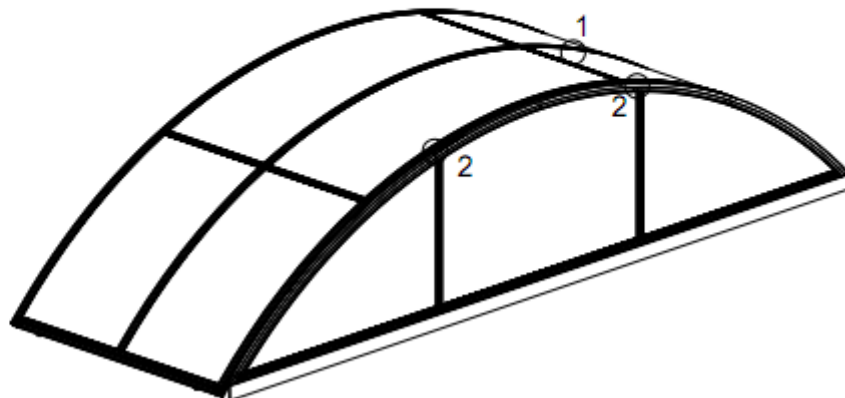

Montera CX på 05-L02A, 10 mm från nederkanten, med Z03.

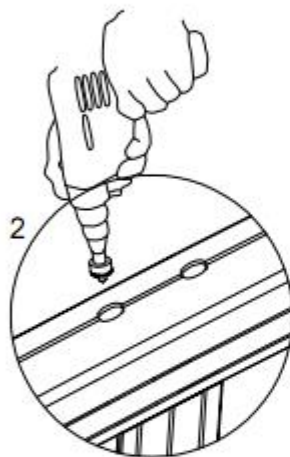
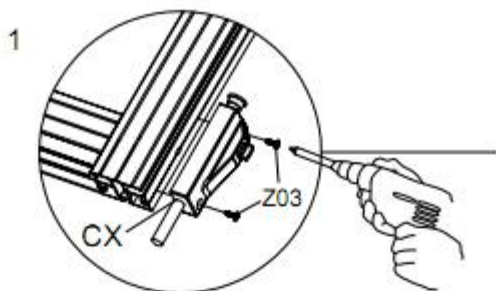



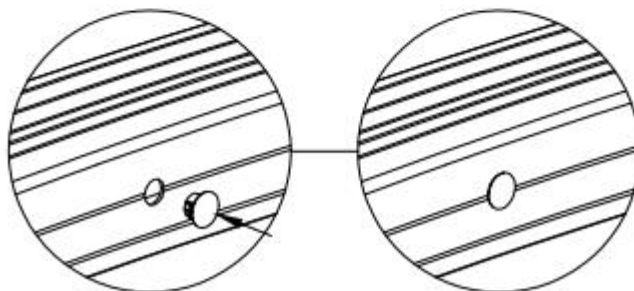

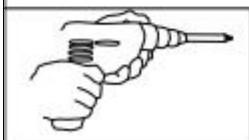

Hålen måste utvidgas till diameter 14 mm, använd en brotsch och en elskruvdragare.



Dölj alla hål med J01



PART	NO	QTY
	L06A	30
	L12	20
	L13	4
	J01	150
	J02	150
	Z01	150
	M6X60	
	Z02	60
	M4.2X16	

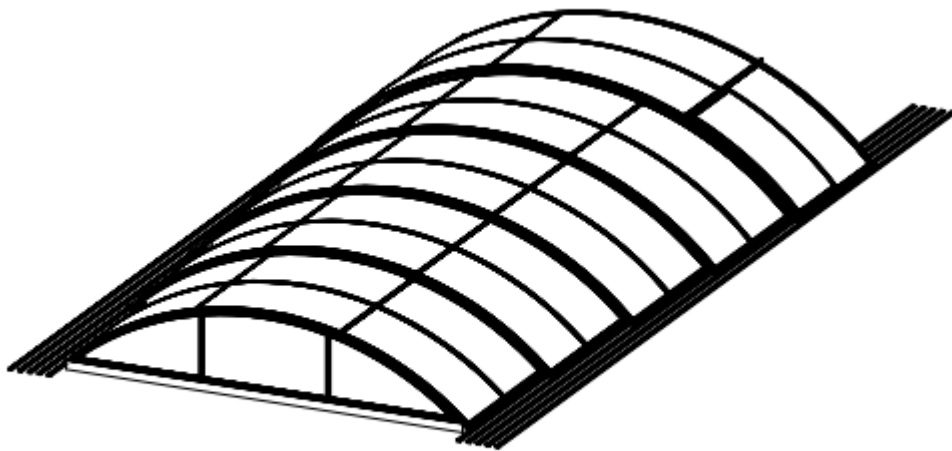

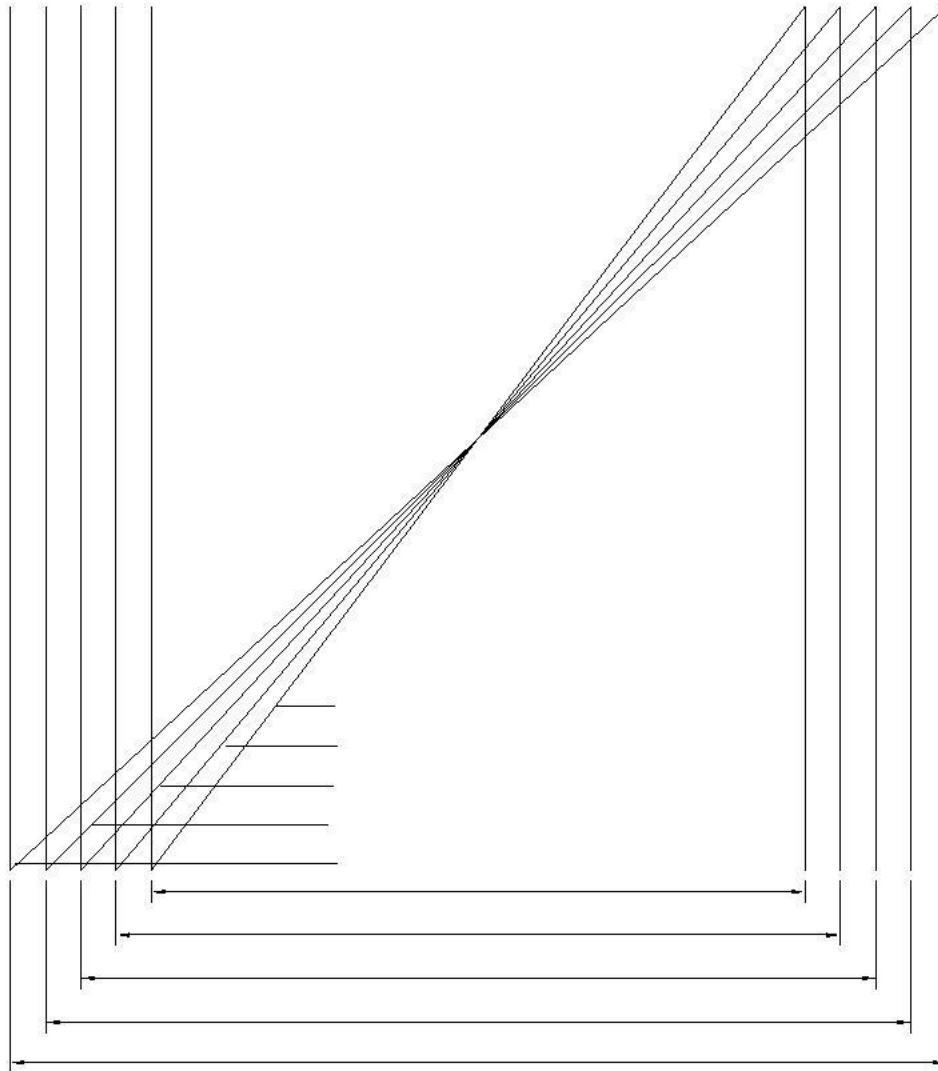

mm \ NR.	1	2	3	4	5
A (mm)	6 410	6 158	5 906	5 654	5 402
B (mm)	14 271	14 153	14 051	13 947	13 847

Mindre avvikelser mellan måtten här och i verkligheten är tillåtna.

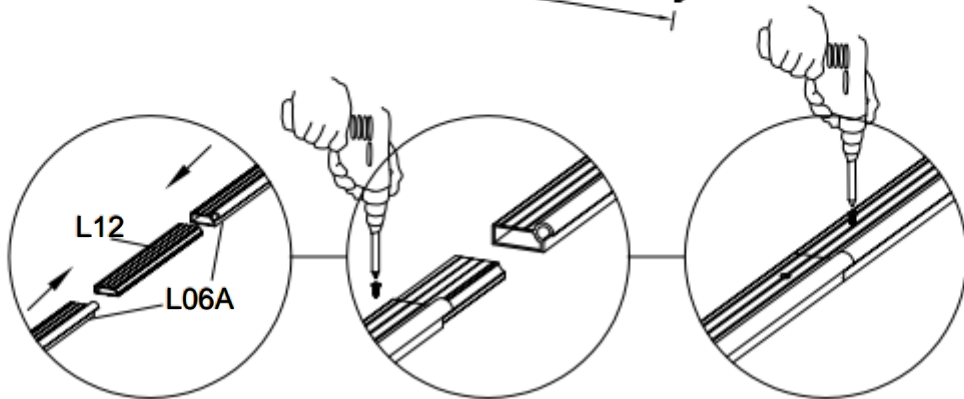
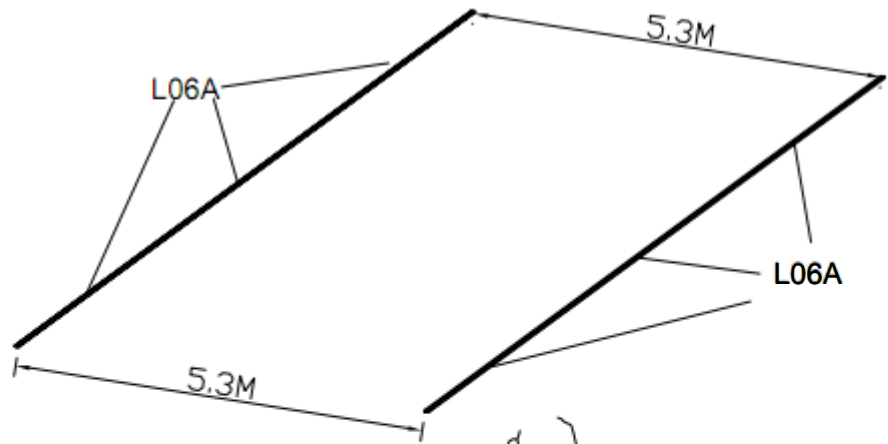

Sätt samman 3 st. L06A-delar till en förlängd del genom att föra in L12 i båda ändarna och fixera dem med Z02.

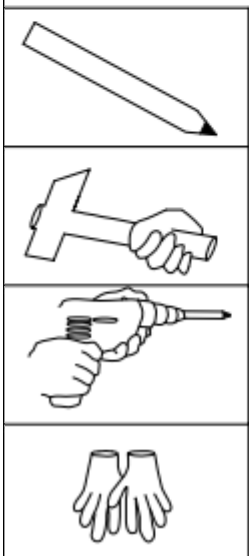
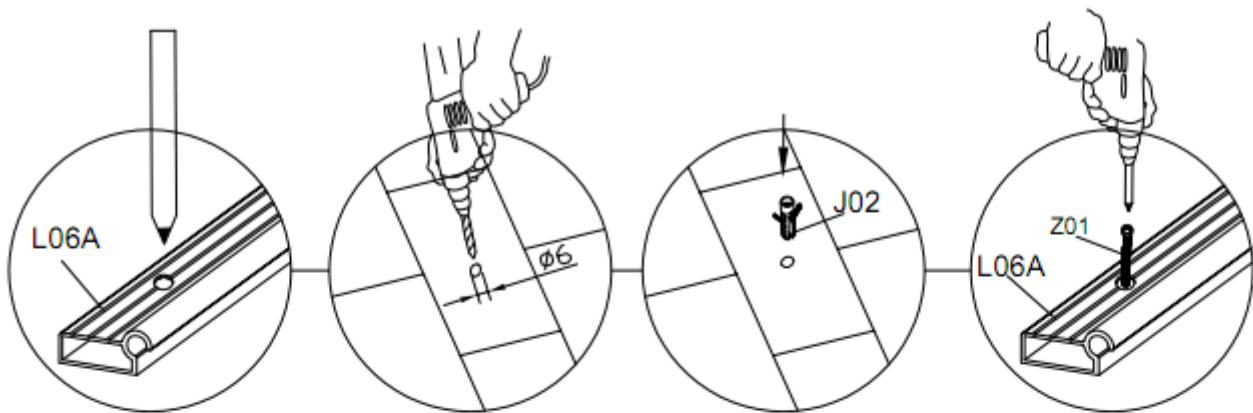

1. Lägg ut 2 st. spår på underlaget med rätt avstånd, se ovan.
2. Markera med en penna genom hålen i det ena spåret och borra sen hål med diameter 6 mm i underlaget.
3. Slå i J02 i hålen och fixera spår nr. 1 på underlaget genom hålen med Z01.
4. Kontrollera att det inre avståndet mellan spår nr. 2 och spår nr. 1 är 5 300 mm och att det yttre avståndet mellan dem är 5 402 mm.
5. Fäst inte spår nr. 2 i underlaget förrän K5 går att flytta smidigt i de två spåren.

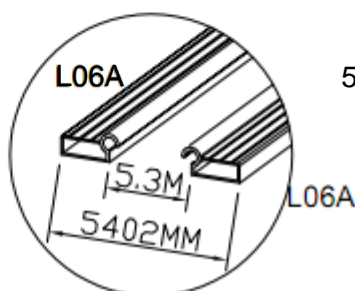

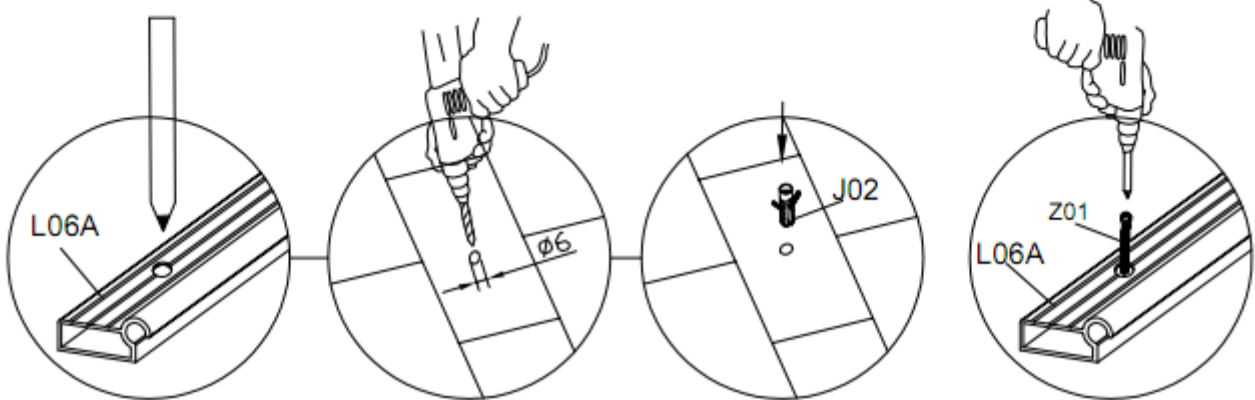
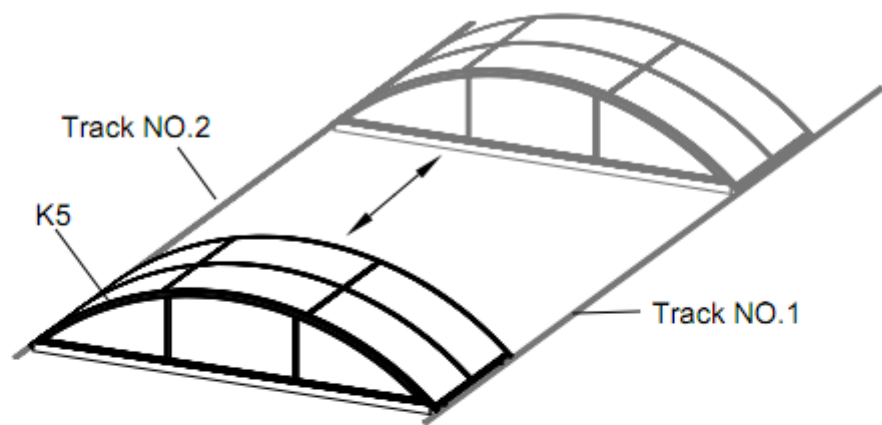

1. Placera K5 i de två spåren och justera spår nr. 2 tills K5 går att flytta smidigt.
2. Markera med en penna på underlaget genom hålen i spåret. Borra sen hål med 6 mm diameter i underlaget.
3. Slå i J02 i hålen och fixera spår nr. 2 i underlaget genom hålen med Z01.

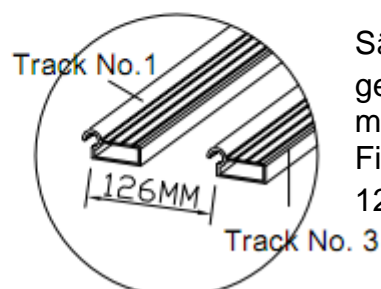
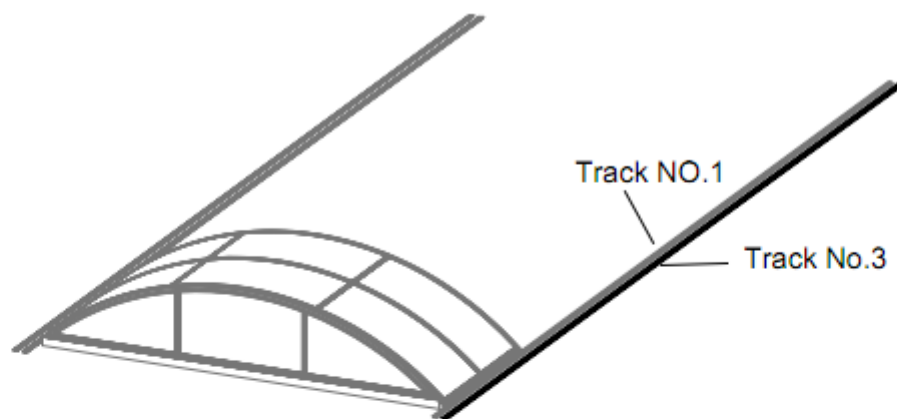

Sätt ihop 3 st. L06A till ett enda förlängt spår genom att föra in L12 i de båda ändarna och fixera dem med Z02.

Fixera spår nr. 3 i underlaget, se ovan, 126 mm från spår nr. 1, se nedan.

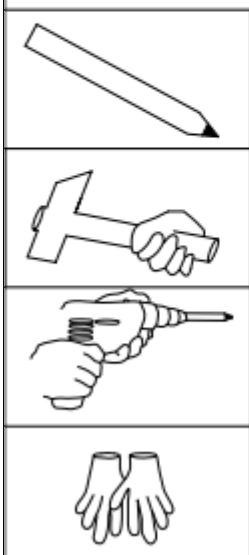

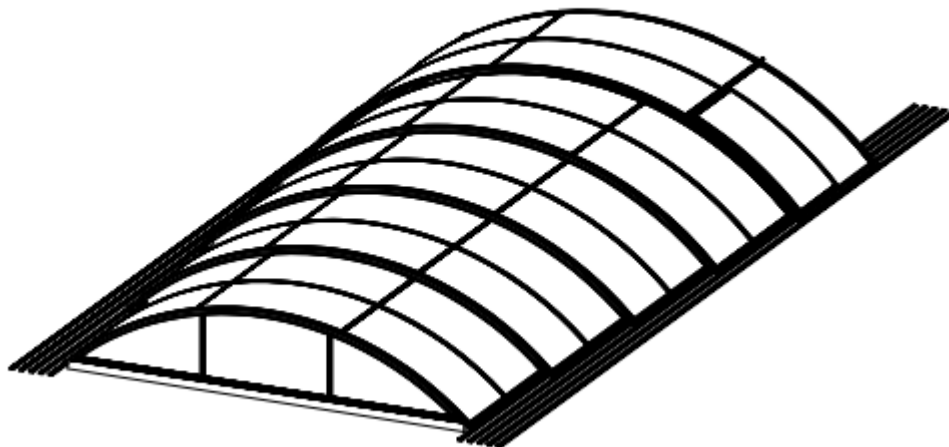

Fixera resterande spår på samma sätt som ovan.  
Se till att alla delar av pooltaket går att flytta smidigt  
innan du drar åt skruvorna ordentligt.

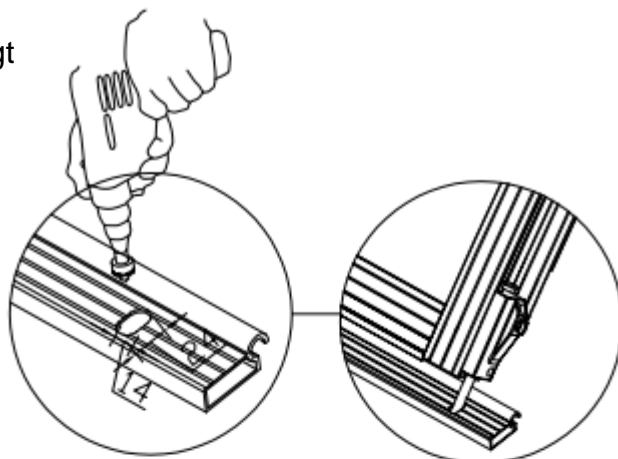
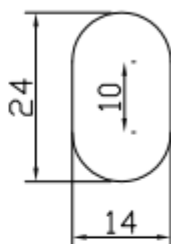

Borra 8 ovala hål (14 x 24 mm) i spåren, motsvarande de 8 låsen (CX).  
På så sätt kan du låsa pooltaket när du stänger det.

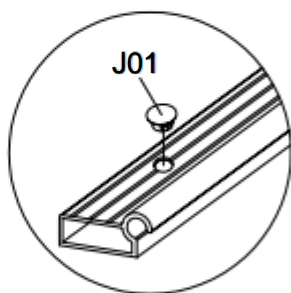

Dölj alla hålen i spåren med J01

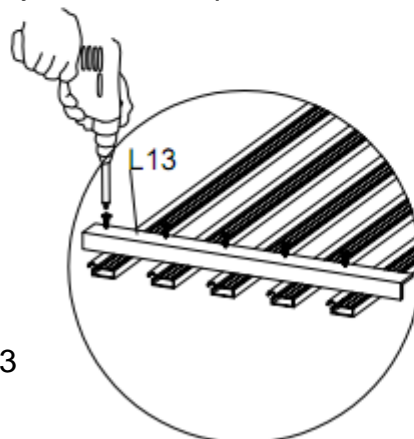

**Konsumentkontakt**  
Arc E-commerce AB  
Box 3124  
13603 Haninge  
Sverige

Sist av allt fäster du L13  
(4 st.) i spårens ändar  
med Z02.

