

# NORO

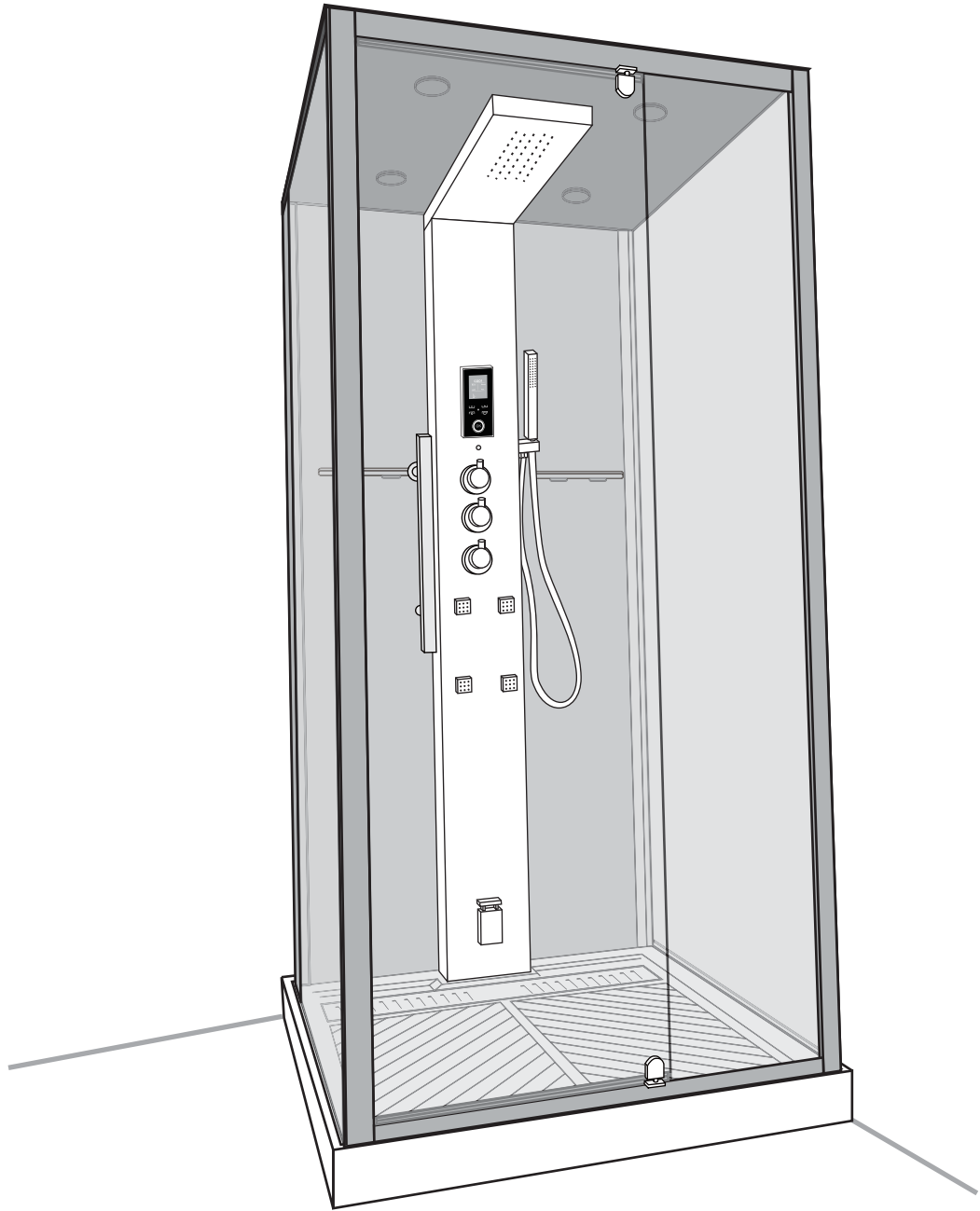

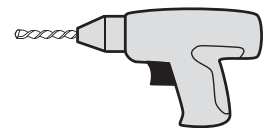

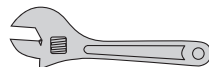

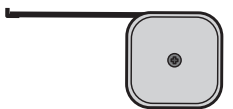

Tools Needed / Verktyg som behövs vid montering /  
Työkalut joita tarvitset asennuksessa / Nødvendig verktøy:













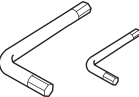

AVANTI

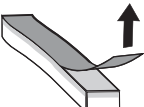
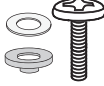
## Getting Started / Att komma igång / Päästäksesi alkuun / Kom i gang:

	<p>(GB) This product fulfils the EN14428 standard                  (SE) Denna produkt uppfyller standard EN 14428.                  (FI) Tämä tuote täyttää EN 14428 normit.                  (NO) Dette produktet oppfyller EN 14428 standard</p>		<p>(GB) All glass used are tempered security glass                  (SE) Allt glas är härdat säkerhetsglas.                  (FI) Kaikki lasit ovat karkaistua turvalasia.                  (NO) Allt glass er herdet sikkerhetsglass.</p>
	<p>(GB) Goggles are recommended to protect the eyes                  (SE) Använd skyddsglasögon vid monteringen av Ångduschen.                  (FI) Käyttäkää suojalaseja höyrysiuhkun asennuksen aikana                  (NO) Bruk vernebriller ved montering av steamdusjen.</p>		
	<p>(GB) Gloves are recommended to prevent slippery on glass                  (SE) Använd halkfria skyddshandskar när glaset skall bäras.                  (FI) Käyttäkää lasia kannettaessa käsineitä jotka eivät luista ( esim. nahkaiset)                  (NO) Bruk sklisikre sikkerhetshansker når glasset skal bæres.</p>		
	<p>(GB) 2 people are recommended to assemble this shower enclosure                  (SE) Vi rekommenderar att man är 2 personer som monterar Ångduschen.                  (FI) Suosittelemme kahta henkilöä höyrysiuhkun asennuksessa.                  (NO) Vi anbefaler at man er 2 personer når man monterer steamdusjen.</p>		
	<p>(GB) Caution: Always Handle Glass With Care! Always protect the edges and corners of the glass when assembling.                  (SE) OBS! Kanter och hörn på härdat säkerhetsglas är mycket känsliga och sätt alltid ner glasskivorna på mjukt underlag.                  (FI) Huom! Karkaistun turvalasin kulmat ja reunat ovat erittäin herkkiä joten laittakaa aina lasilevyt pehmeälle alustalle.                  (NO) OBS! Kanter og hjørner på sikkerhetsglass er veldig sårbar, sett derfor glasset på et mykt underlag.</p>		

## Accessories Bags / Tillbehörspåsar / Lisävarustepakkaus / Tilbehørsposen:

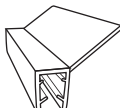
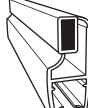
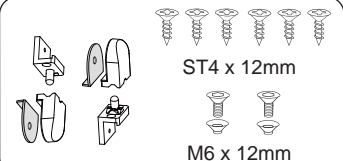
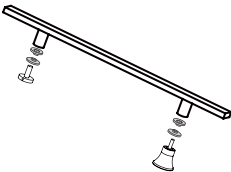
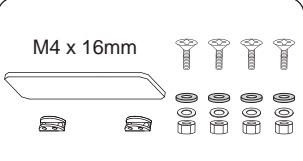
<p>01</p>  <p>M4 x 20mm x 12</p>	<p>02</p>  <p>M6 x 25mm x 4</p>	<p>03</p>  <p>ST4 x 10mm x 4</p>	<p>04</p>  <p>Ø3.2mm x 1</p>	<p>05</p>  <p>4mm 2mm x 1</p>	<p>17</p>  <p>x 1</p>	<p>18</p>  <p>x 1</p>
<p>08</p>  <p>x 1</p>	<p>09</p>  <p>M6 x 25mm x 8</p>	<p>10</p>  <p>x 4</p>	<p>24</p>  <p>x 1</p>	<p>37</p>  <p>330mm x 4</p>	<p>36</p>  <p>888mm x 4</p>	<p>38</p>  <p>x 2</p>
<p>39</p>  <p>x 1</p>	<p>40</p>  <p>x 1</p>	<p>43</p>  <p>ST4 x 12mm M6 x 12mm x 1</p>		<p>47</p>  <p>x 1</p>	<p>48</p>  <p>M4 x 16mm x 2</p>	

- Ⓒ **Dimensions for Power Supply, Water Supply, Drain Hole**
- Ⓒ **Dimentioner för anslutningskabel, Vattenanslutning och bottenventil**
- Ⓒ **Mitat sähköliitintään, vesiliitintään ja vedenpoistoon.**
- Ⓒ **Dimensjon for tilslutningskabel, vanntilslutning og bunnventil.**
- Ⓒ Earthed appliances permanently connected to fixed wiring.  
Appliances supplied through a residual current device having a rated residual operating current no exceeding 30mA.
- Ⓒ Delar som skall skyddsjordas.  
Ångduschen måste var ansluten I serie med en jordfelsbrytare på max brytström av 30mA.
- Ⓒ Osat jotka vikavirtasuojattava.  
Höyrysuihku on kytkettävä vikavirtasuojaan max 30mA katkaisuvirtaan.
- Ⓒ Deler som skal sikkerhetsjordes  
Steamdusjen må vare tilkoblet i serie med en jordfeilsbryter med maks 30mA sikring.

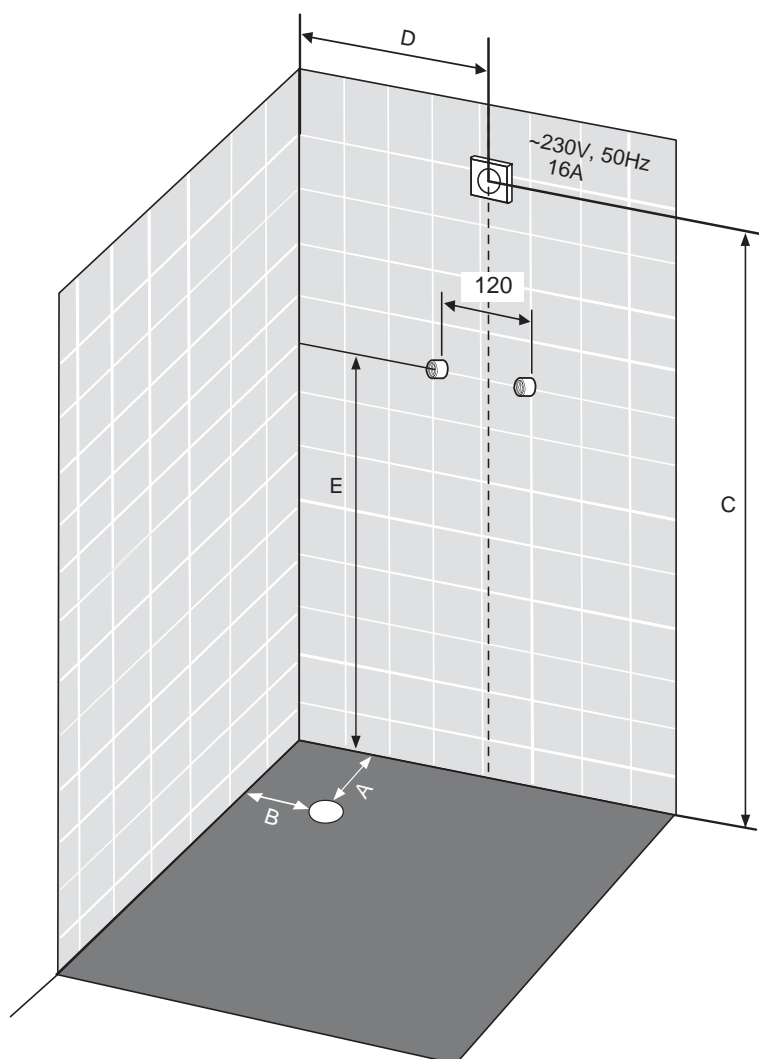

**Suggested Dimension / Rekommenderad dimention / Suositeltu koko / Anbefalte dimensjoner:**

Model/Modell/Malli/Modell	A	B	C	D	E
<b>100x100</b>	300mm	300mm	2280mm	470mm	1150mm

Exploded View / Sprängskiss / Räjätokuva / Sprengskisse:

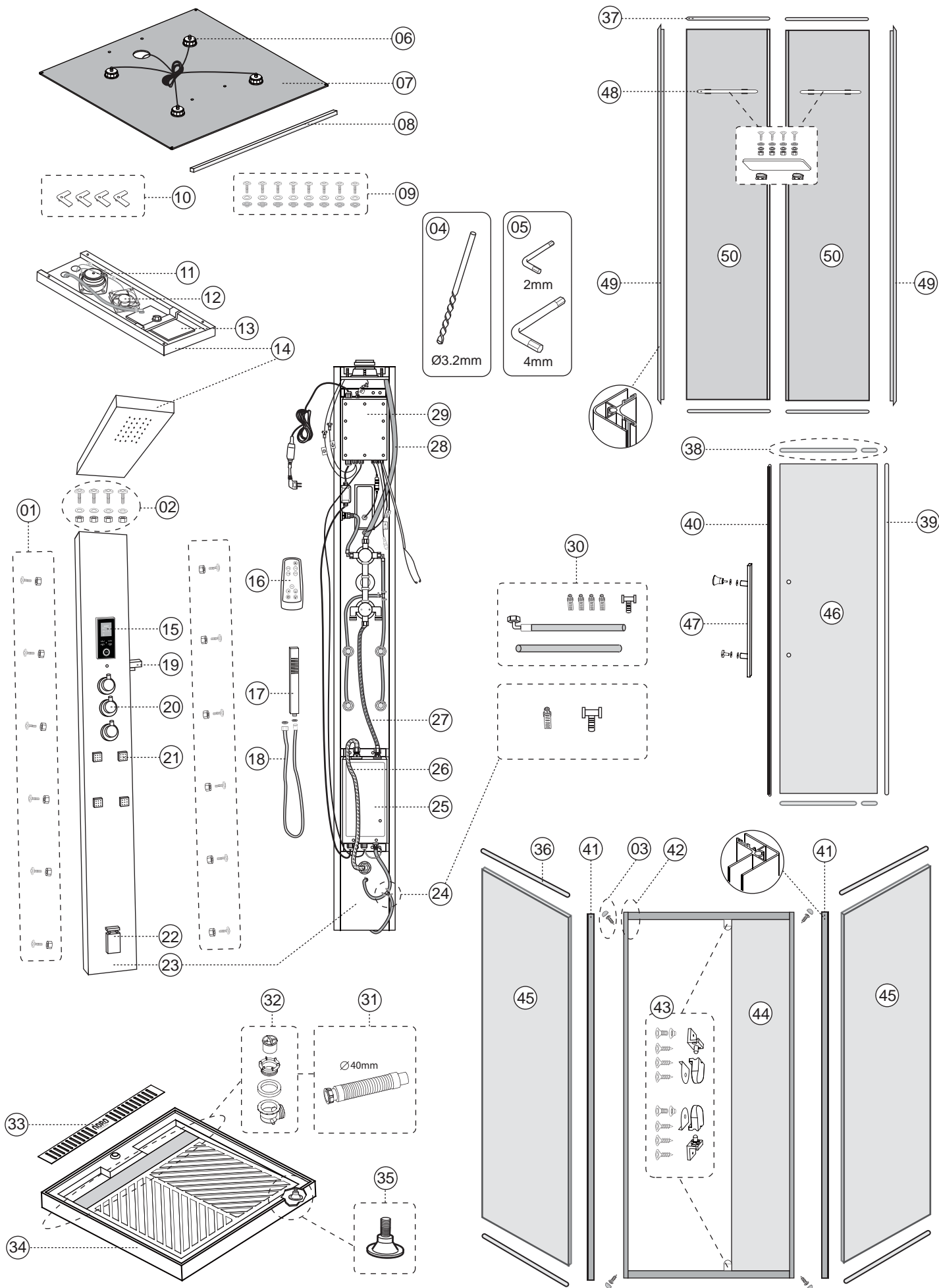

Drawing Nr.	Art Nr.	Description
01	9250-A	M4x20mm screws
02		M6x25mm screws (on column)
03		ST4x10mm screws with screw cover
04		3.2mm drill bit
05		Allen key (4mm & 2mm)
06	9250-B	LED light (roof)
07	9250-C	Roof glass
08	9250-D	Adhesive tape for roof
09		M6x25mm screws for roof
10		Corner gasket for roof
11	9250-E	Speaker
12	9250-F	Fan
13	9250-G	Tropic rain shower head
14	9250-H	Overhead panel for Avanti
15	9250-I	Control panel
16	9250-J	Remote control
17	9250-K	Shower head
18	9400-I	Stainless steel hose (1500mm)
19	9250-M	Shower head outlet and holder
20	9473-W	Thermostatic mixer
21	9250-N	Spray nozzle
22	9370-U	Steam outlet set
23	9250-P	Column for Avanti
24	9250-Q	T-connection and hose clip
25	9250-R	Steam generator
26	9250-S	Steam hose
27		Grey water hose
28		Grey hose set
29	9250-T	Computer box for Avanti
30	9250-U	Gray hose set for nozzles
31	9250-V	Drainage pipe (Ø40mm)
32	9250-W	Drainage set
33	9250-X	Drainage cover
34	9250-Y	Marble tray (complete set)
35	9250-Z	Bolt with PVC leg
36	9250-AA	Upper / lower side panel gasket (888mm)
37		Upper / lower back panel gasket (330mm)
38		Bottom gasket for door
39	9250-AB	h-shape gasket
40		Magnetic gasket
41	9250-AC	Side panel corner profile
42	9250-AD	Aluminium profile set on door
43	9250-AE	Door hinge set complete
44	9250-AF	Door side panel
45	9250-AG	Side panel glass
46	9250-AH	Glass door
47	9145-F	Noro stainless steel handle
48	9250-AI	Glass shelf
49	9250-AJ	Back panel corner profile
50	9250-AK	Back panel

Measurement / Mått / Mitta / Mål:

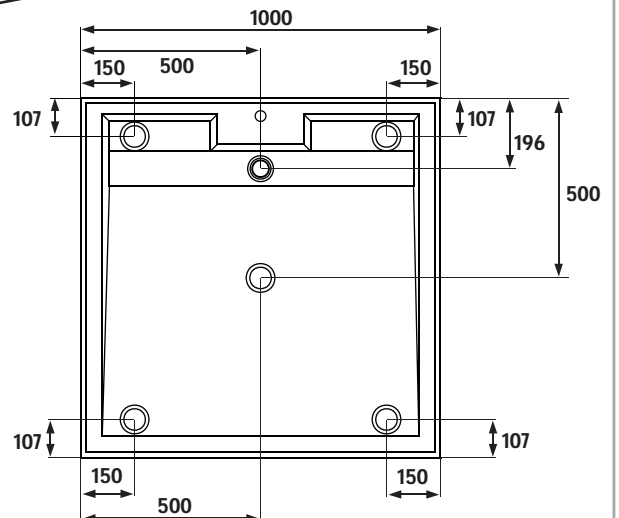
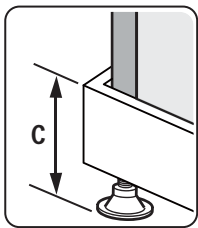
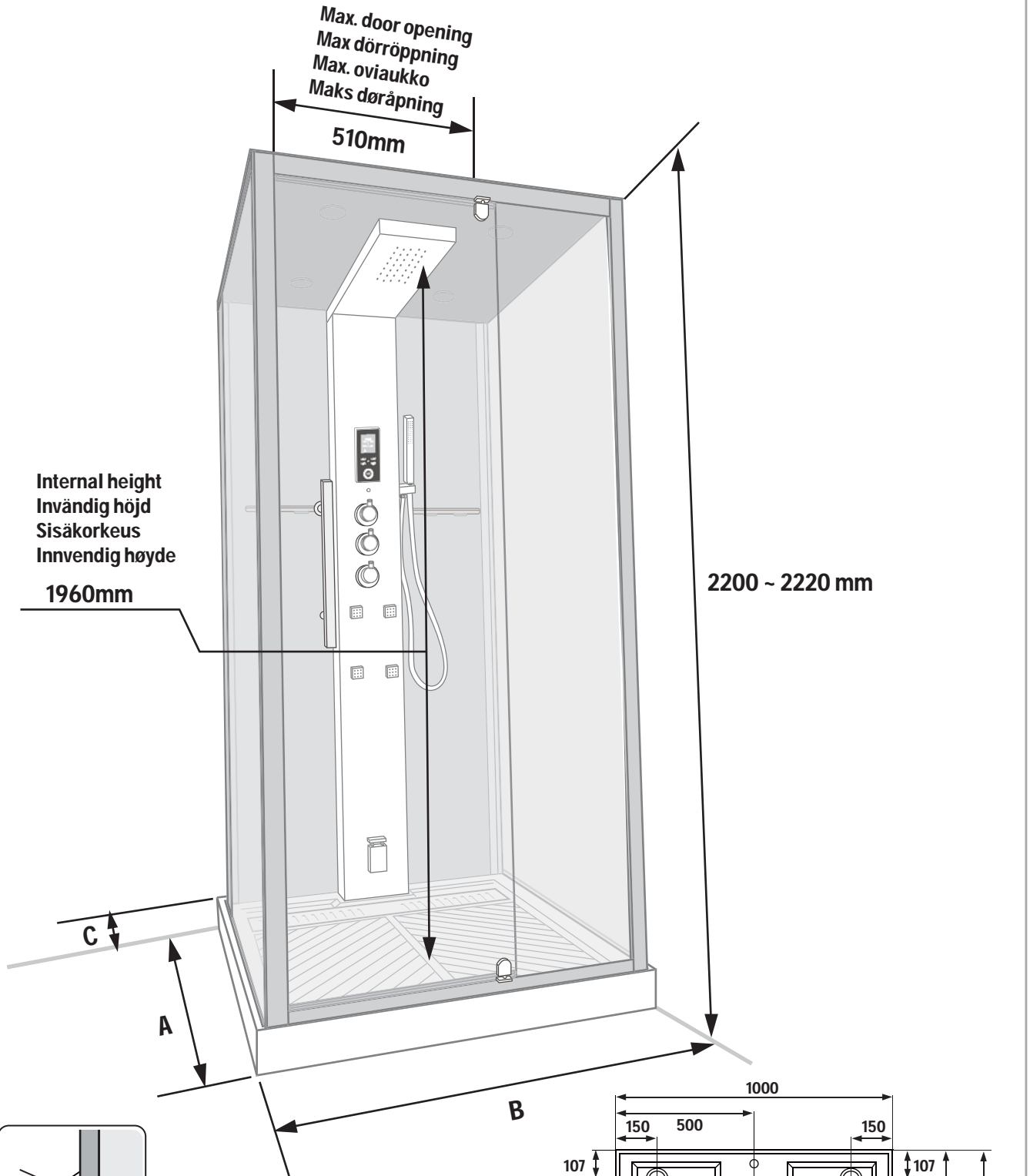

Model	A	B	C
100x100	1000mm	1000mm	140~160mm

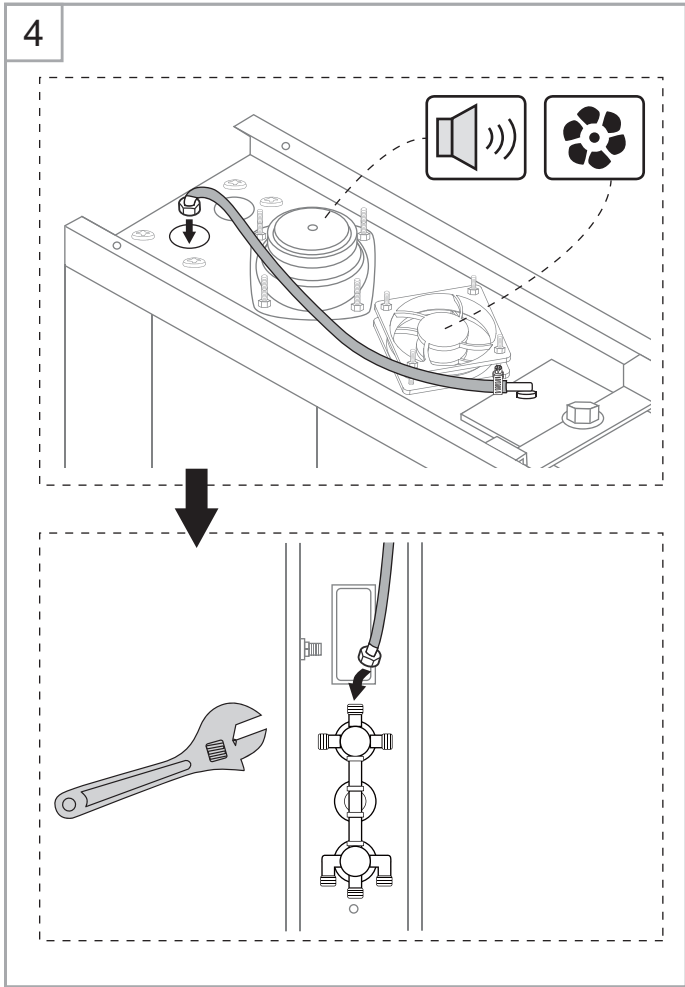
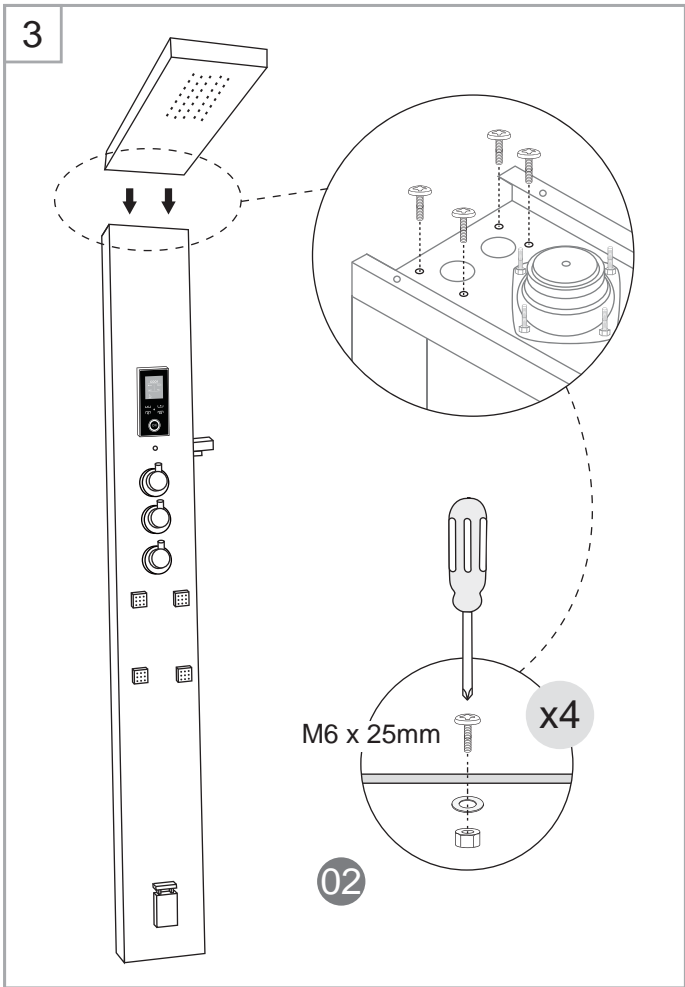
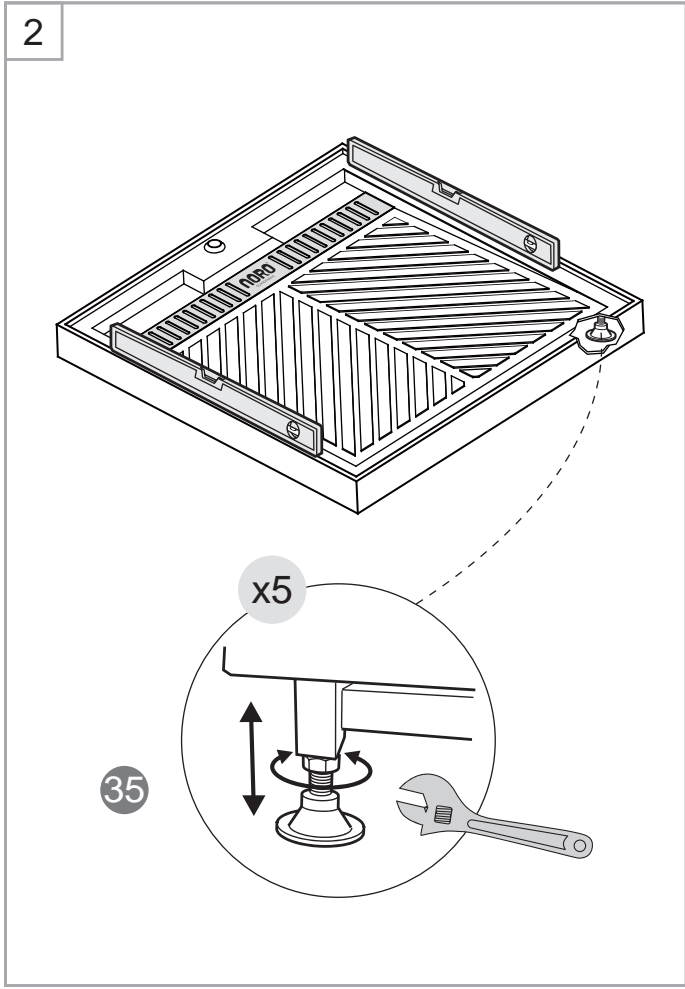
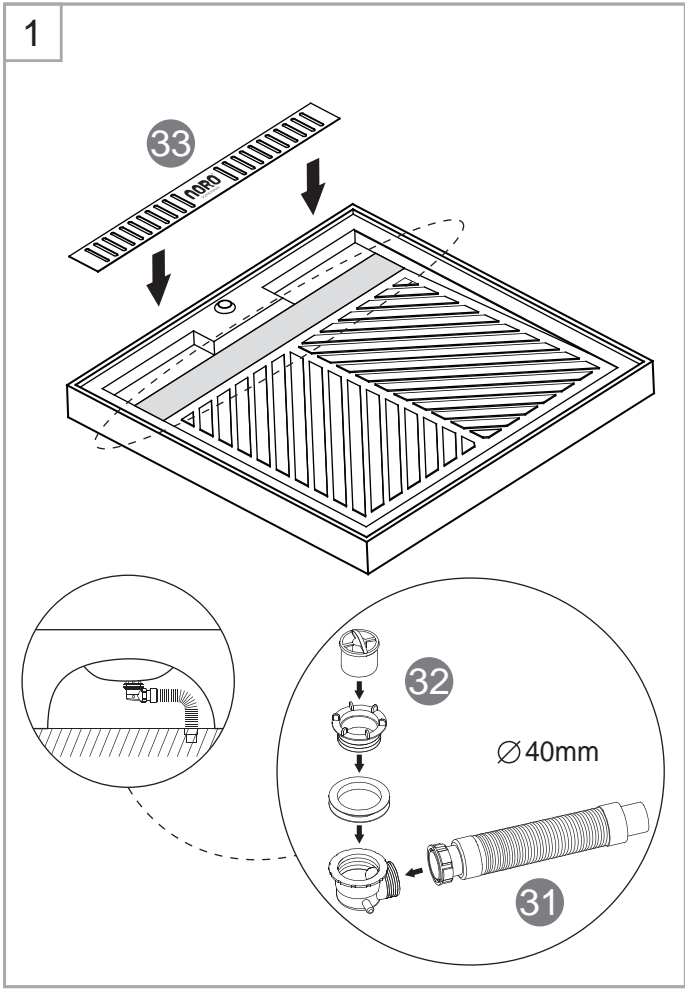

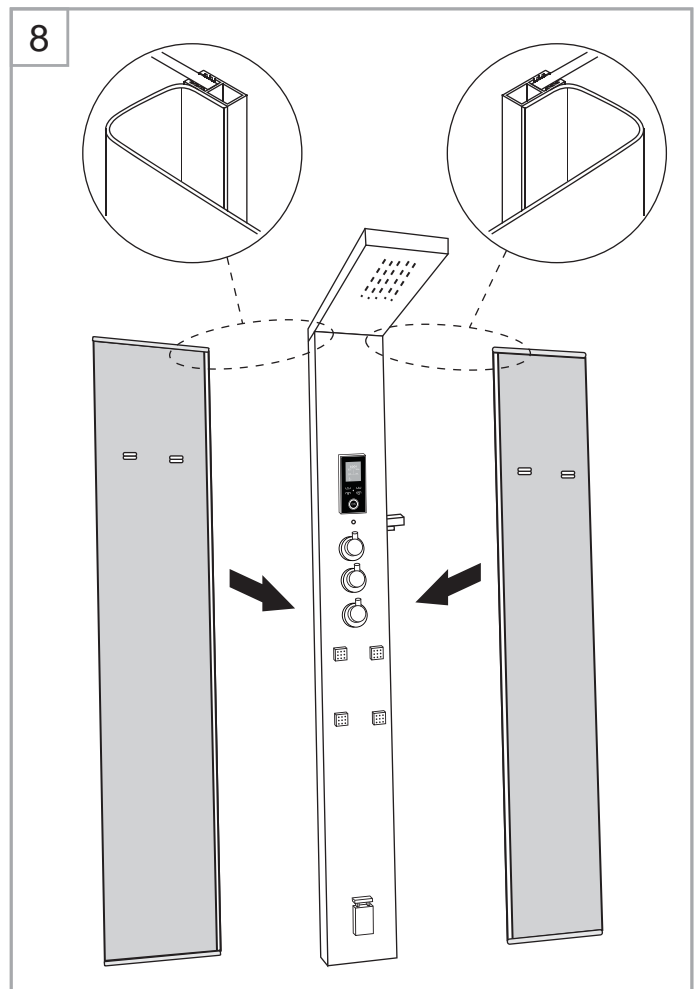
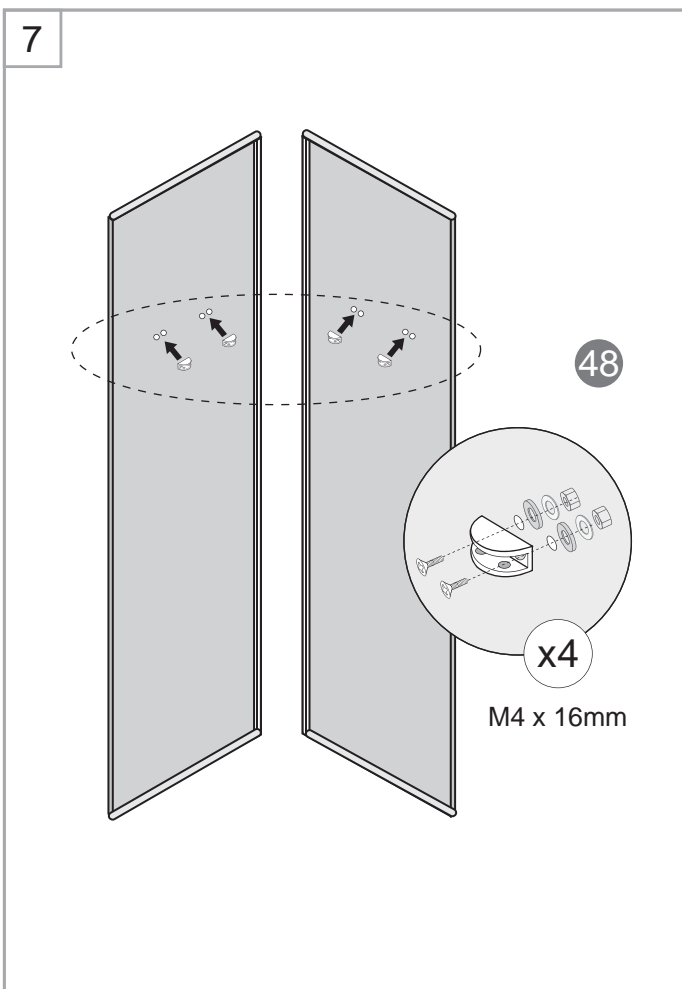
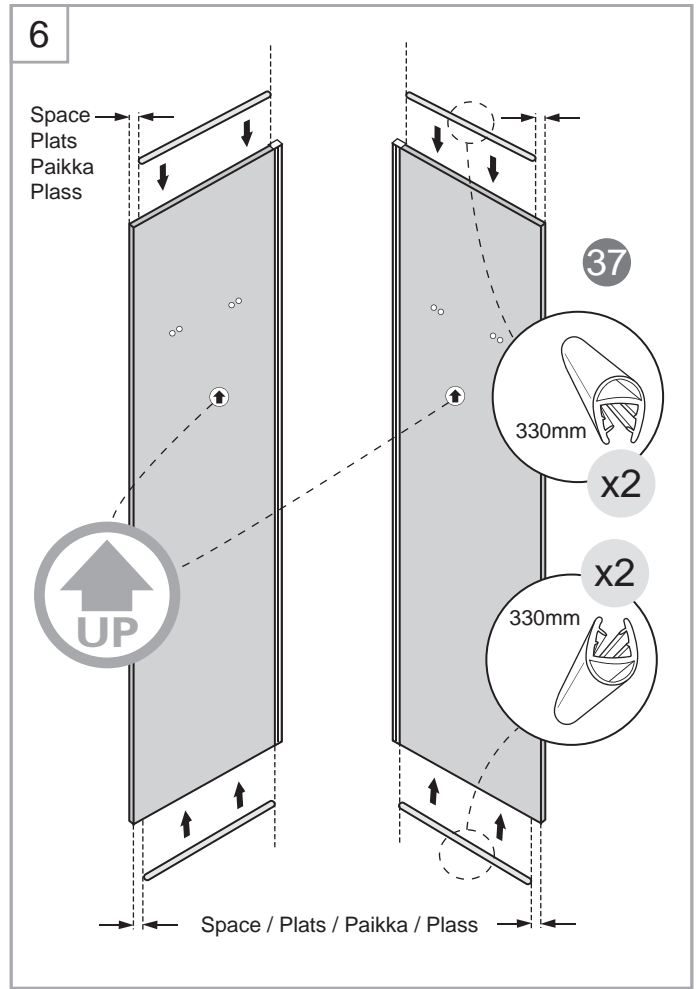
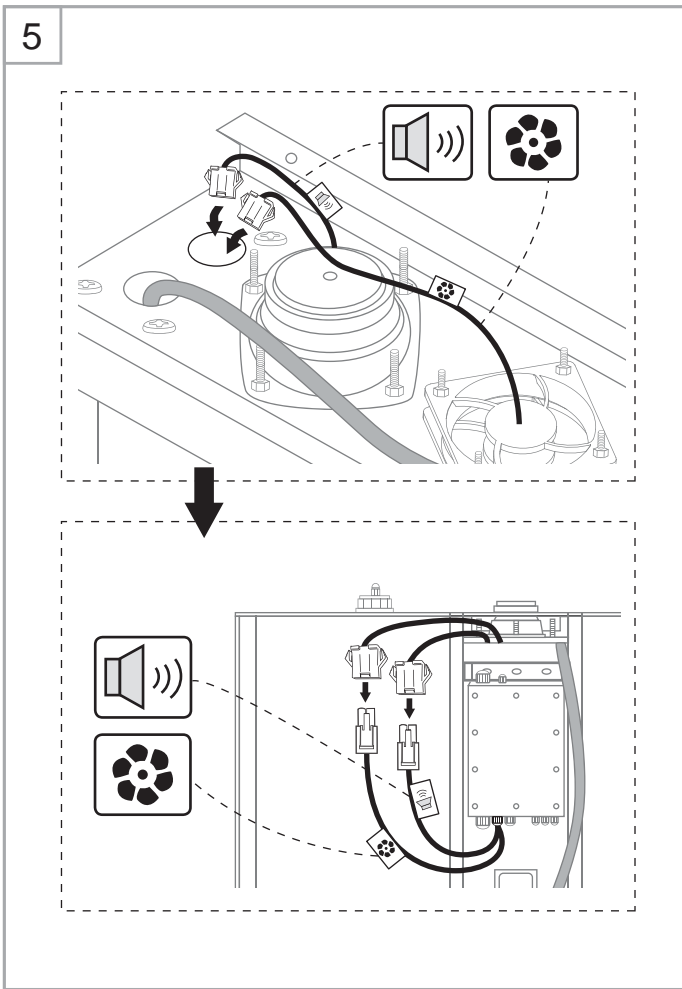

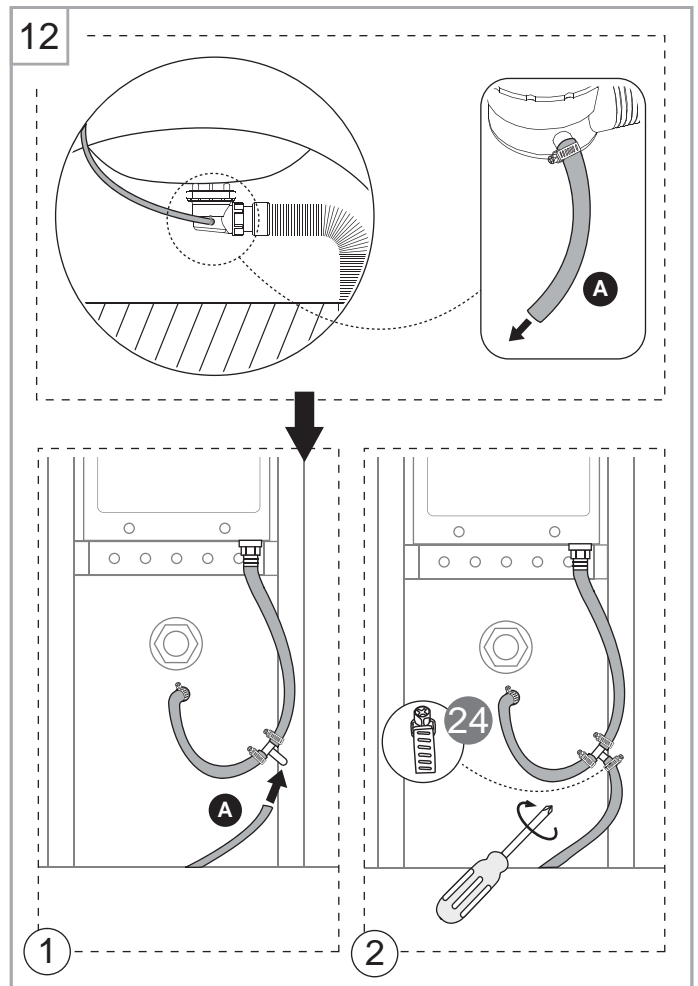
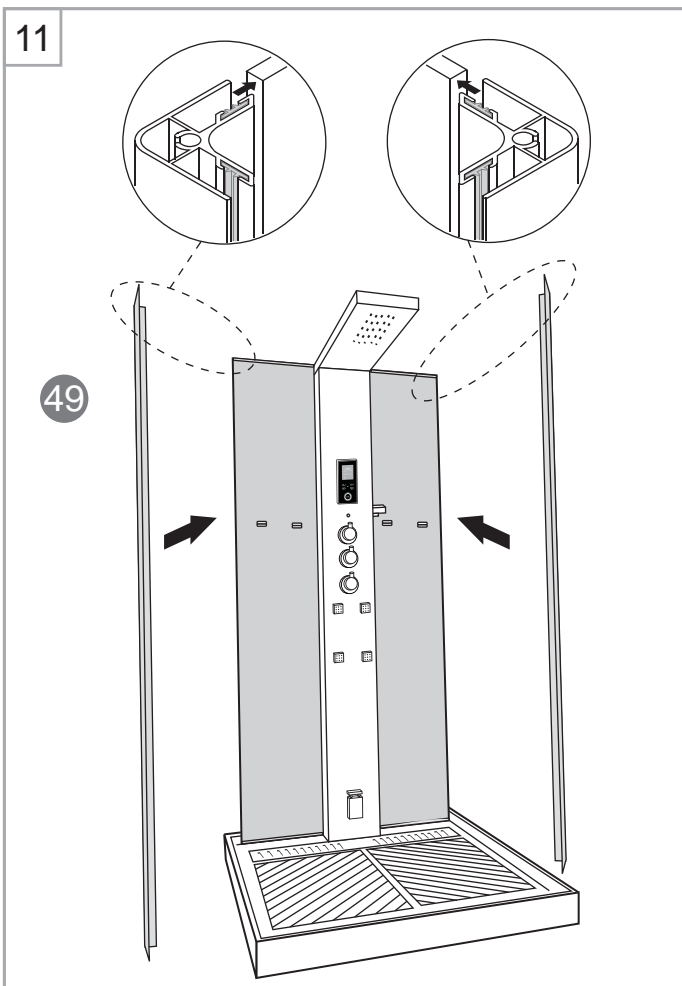
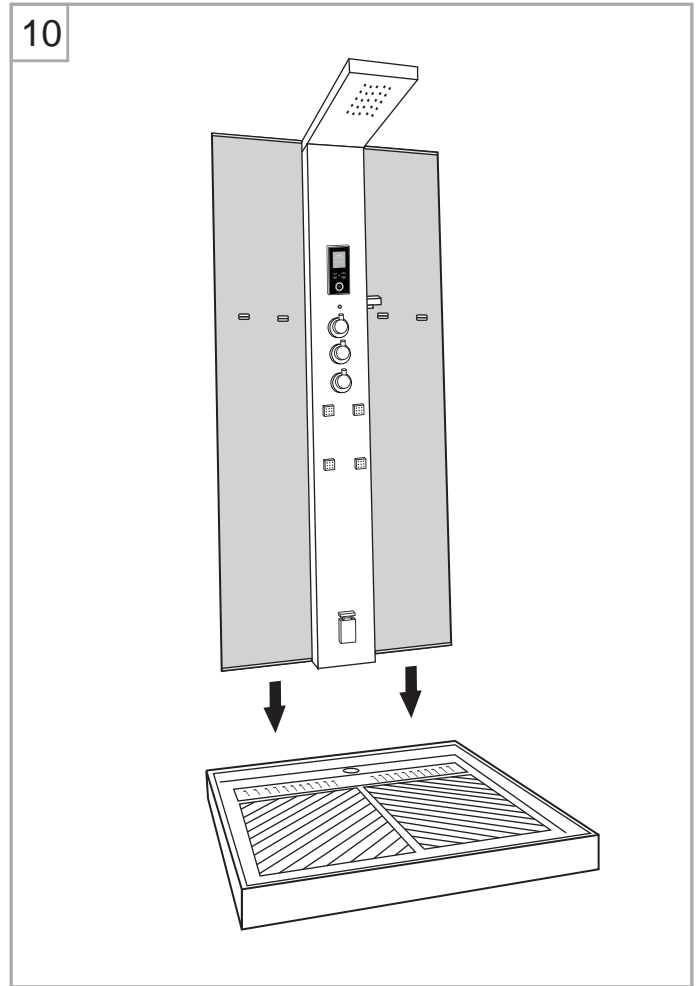
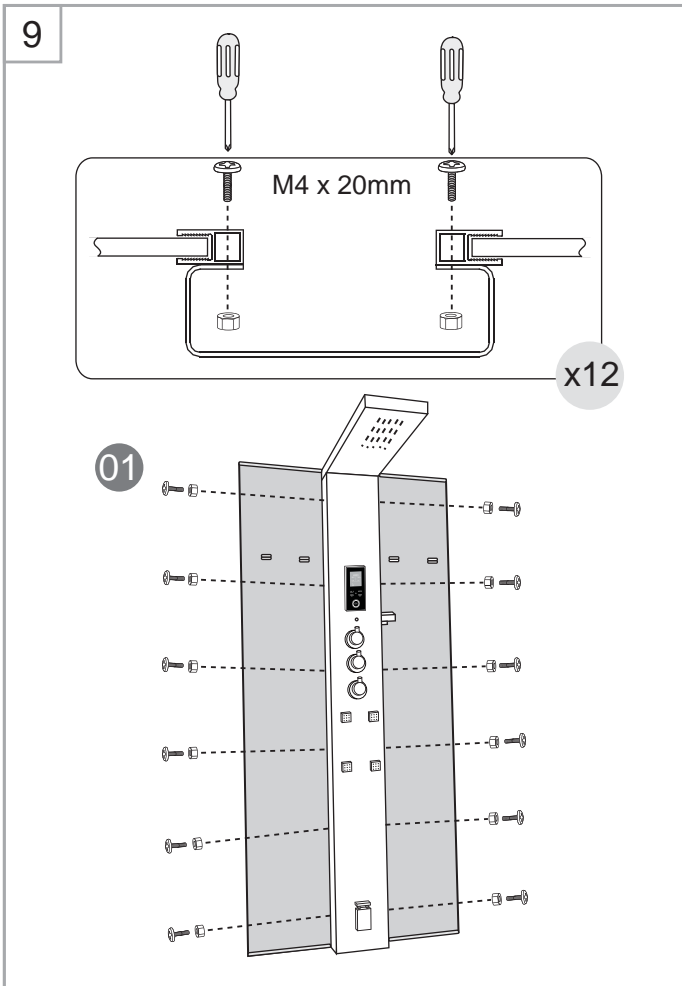

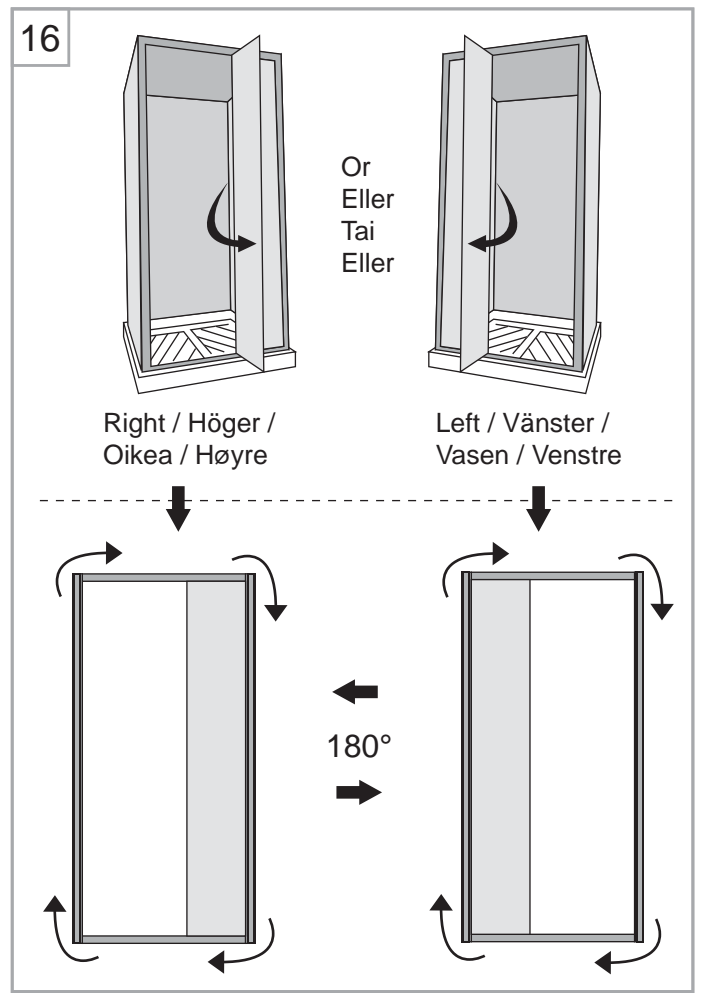
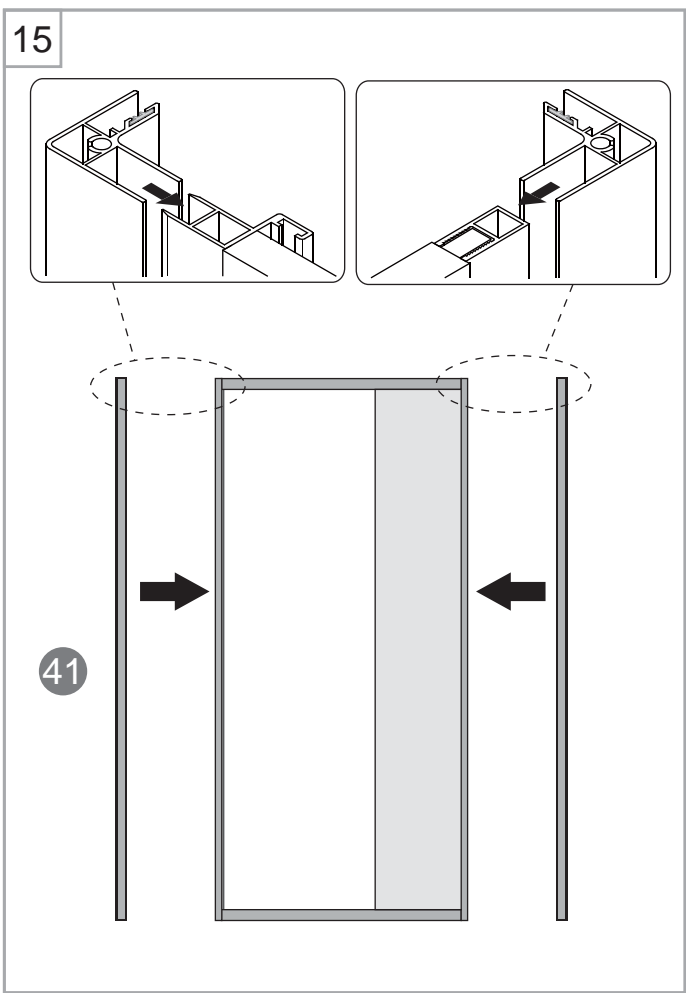
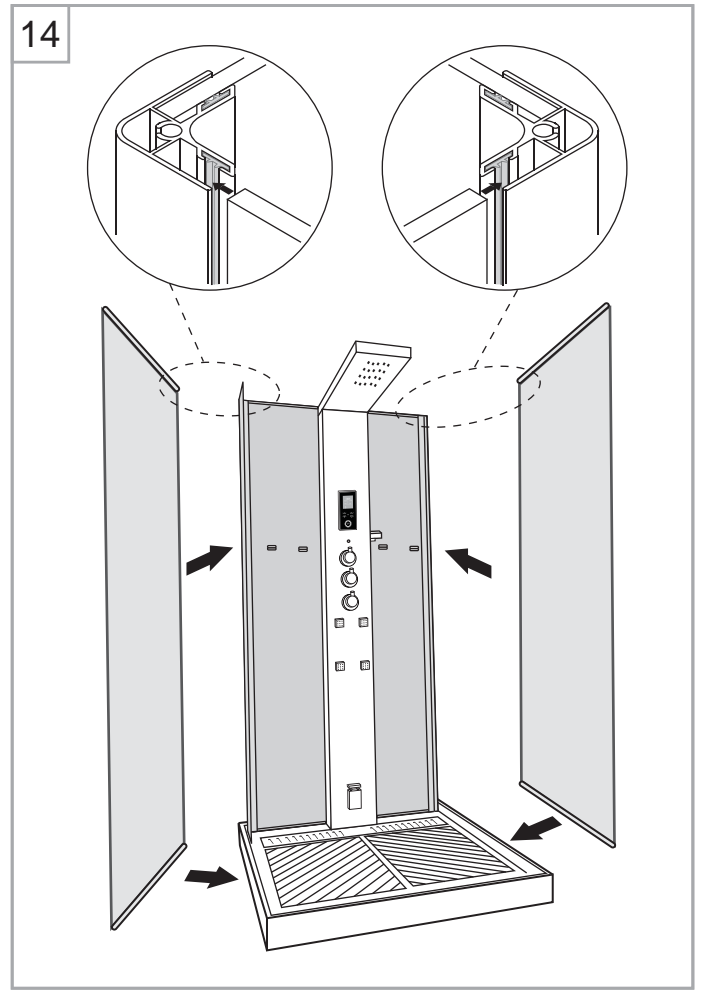
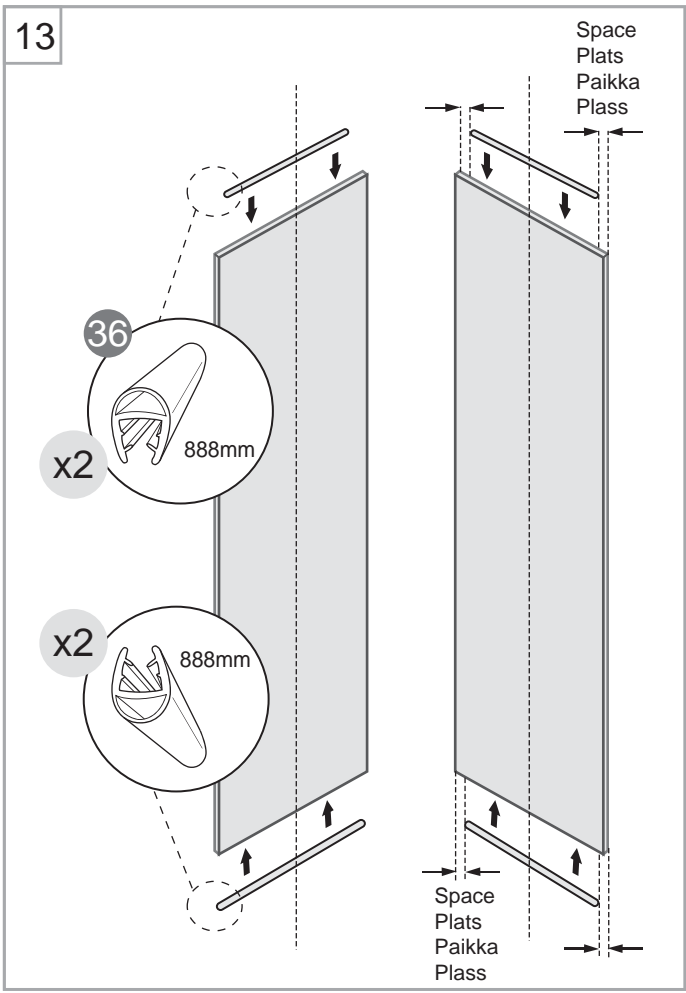

17

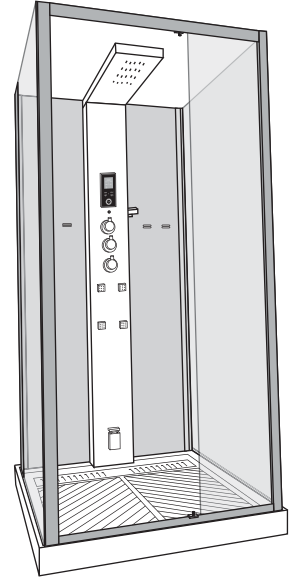
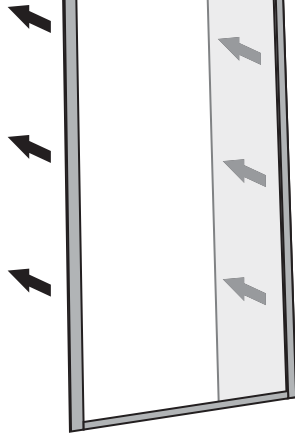
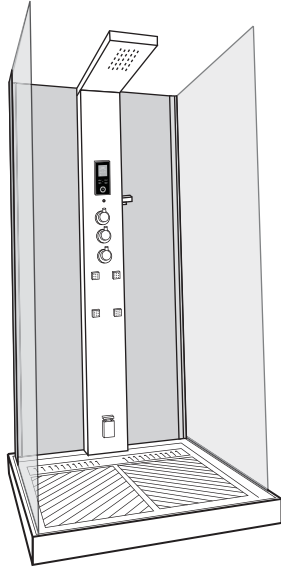
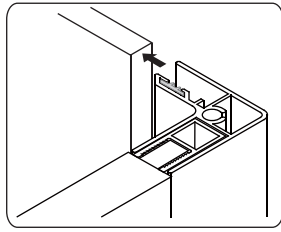
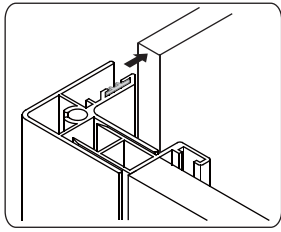

18

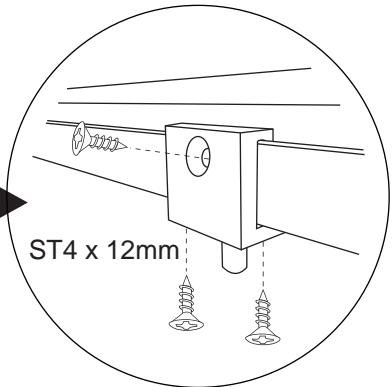
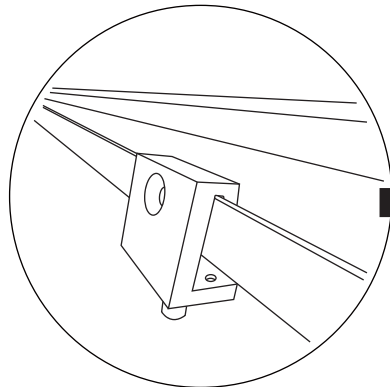
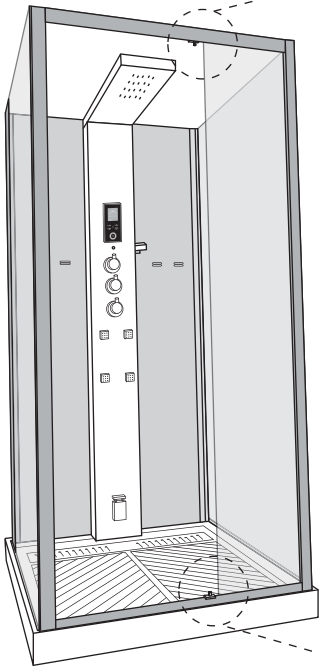

43

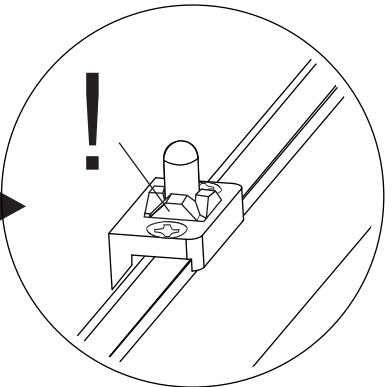
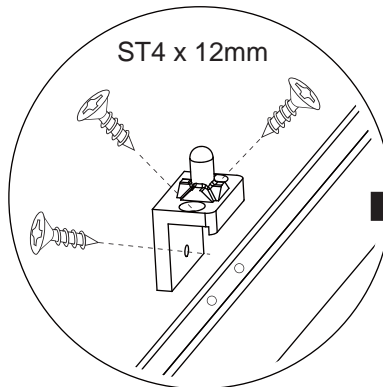

19

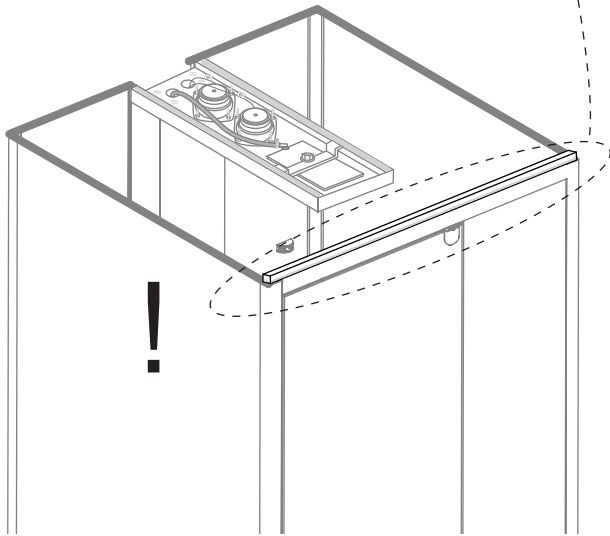
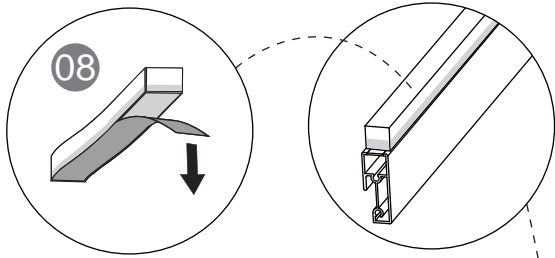

20

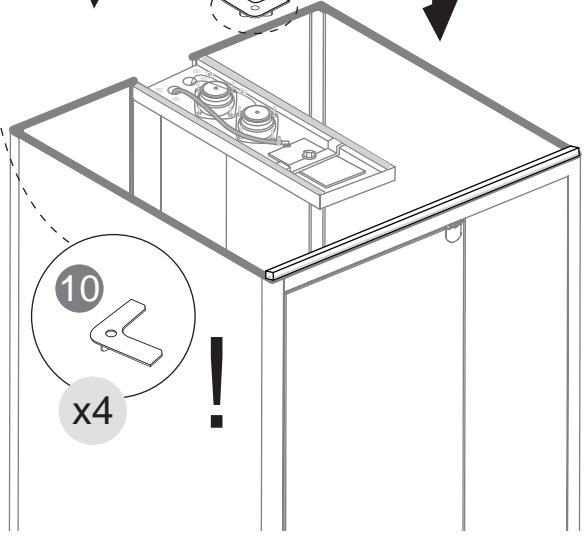
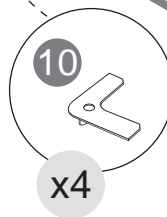
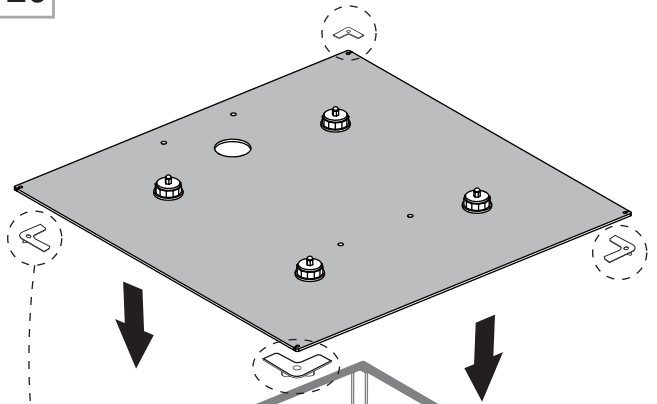

21

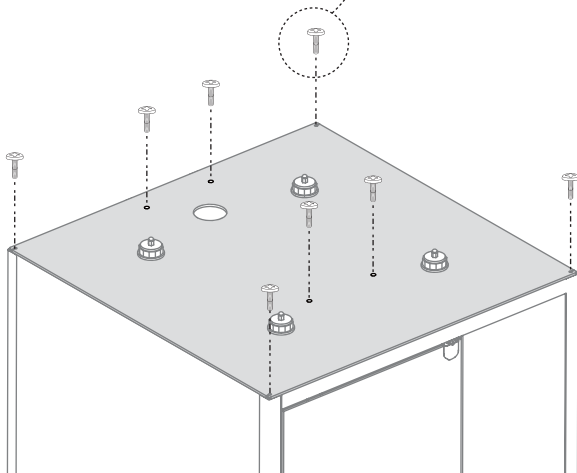
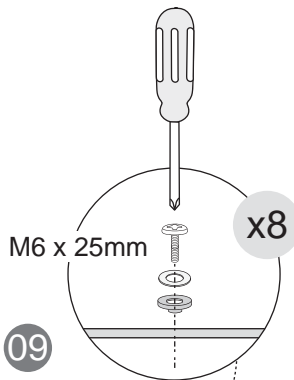

22

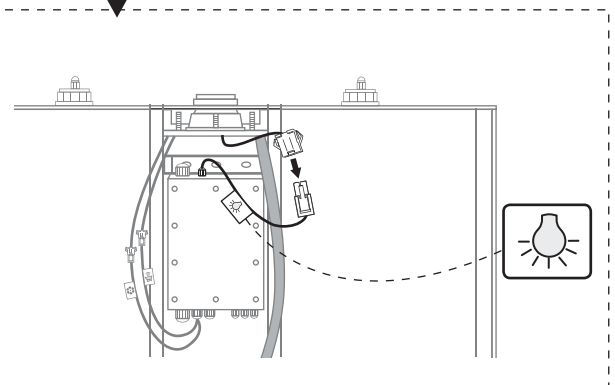
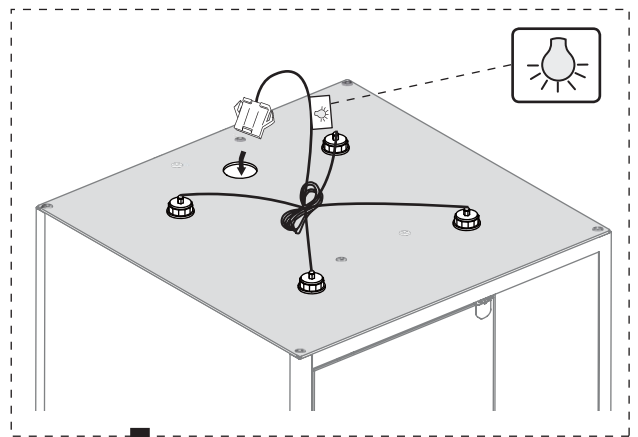

23

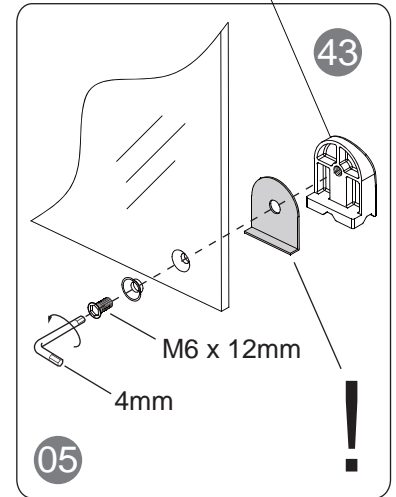
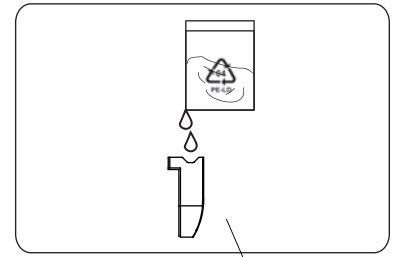
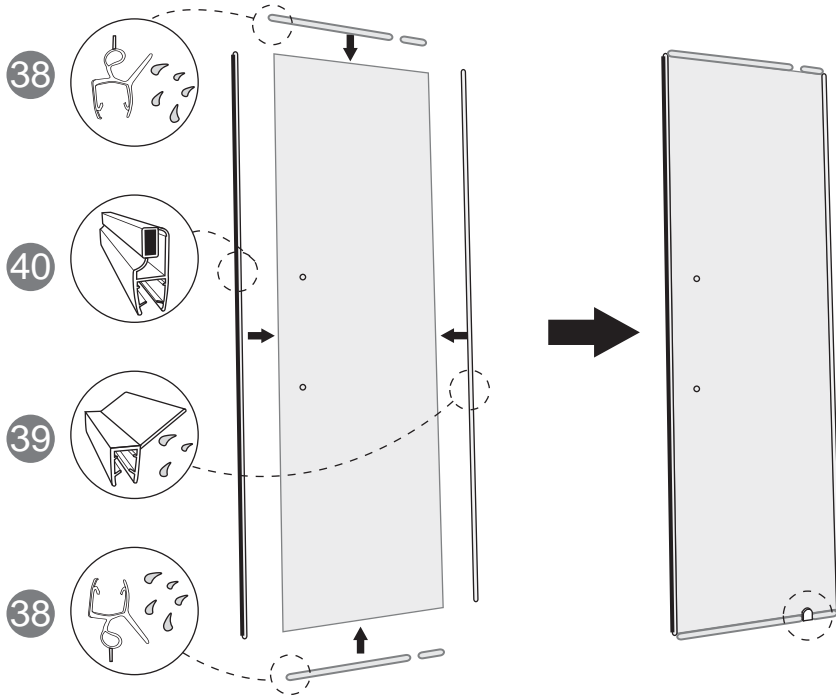

24

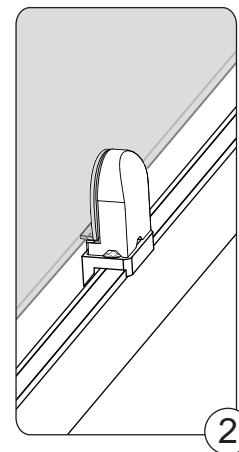
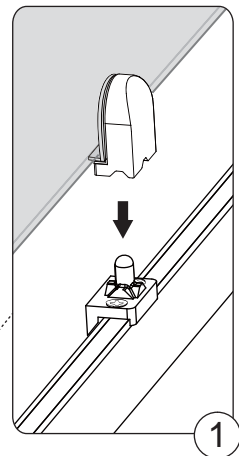
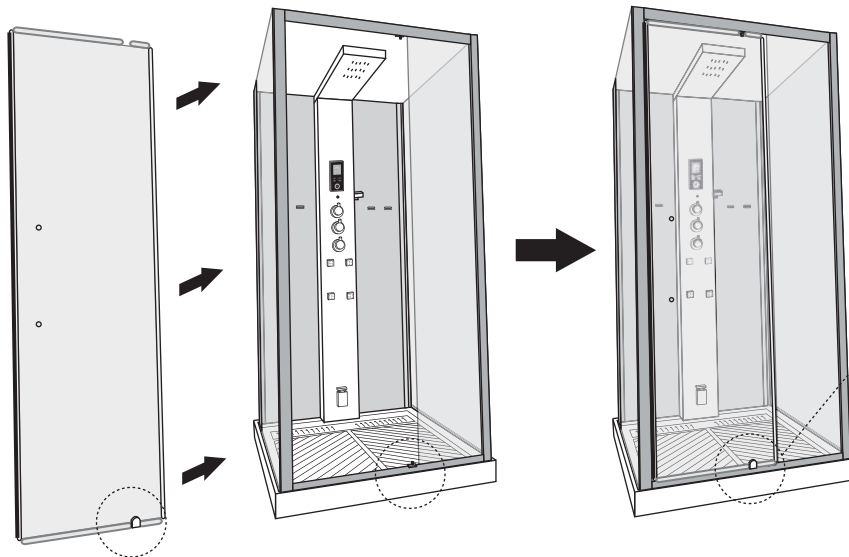

25

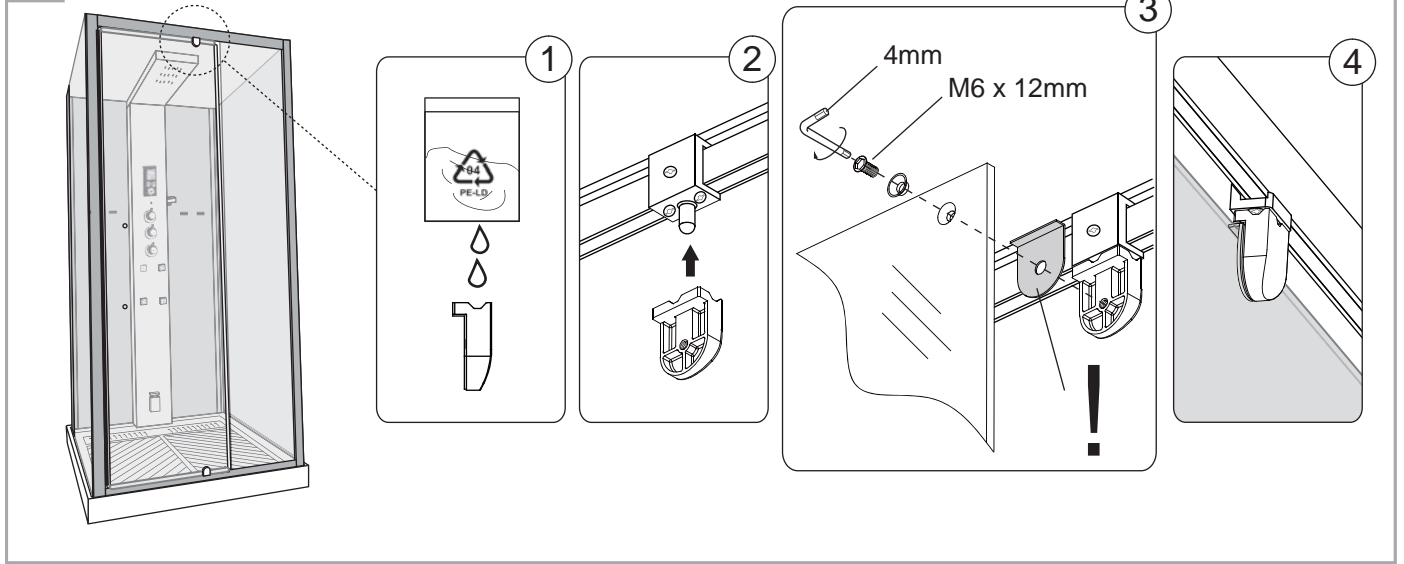

26

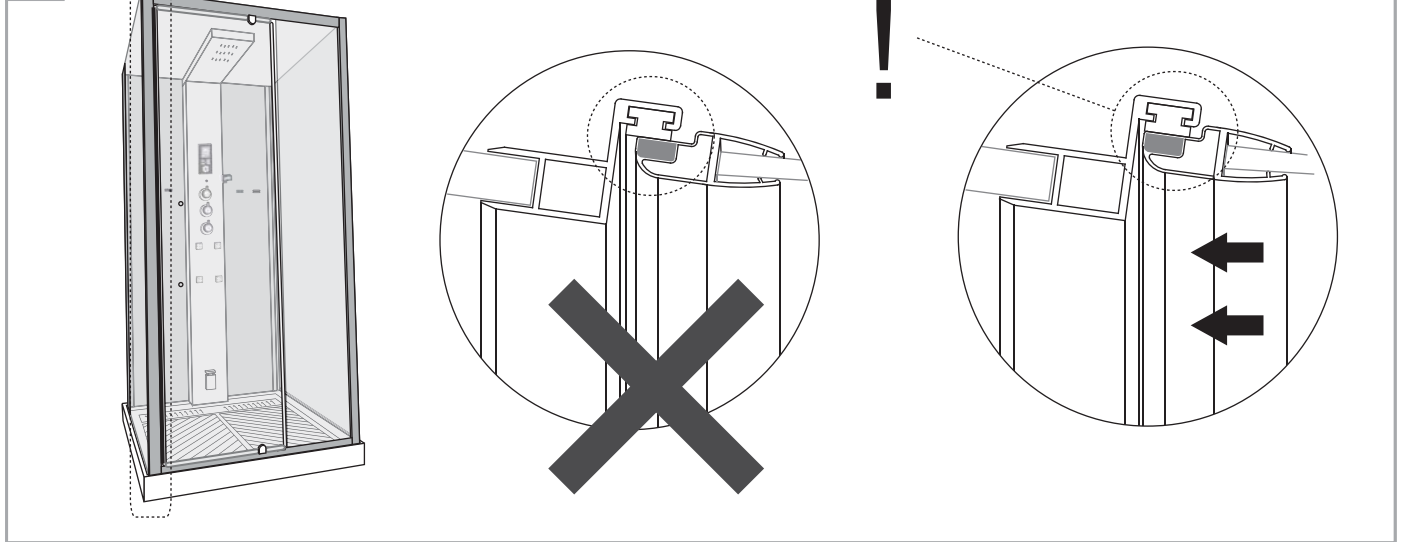

27

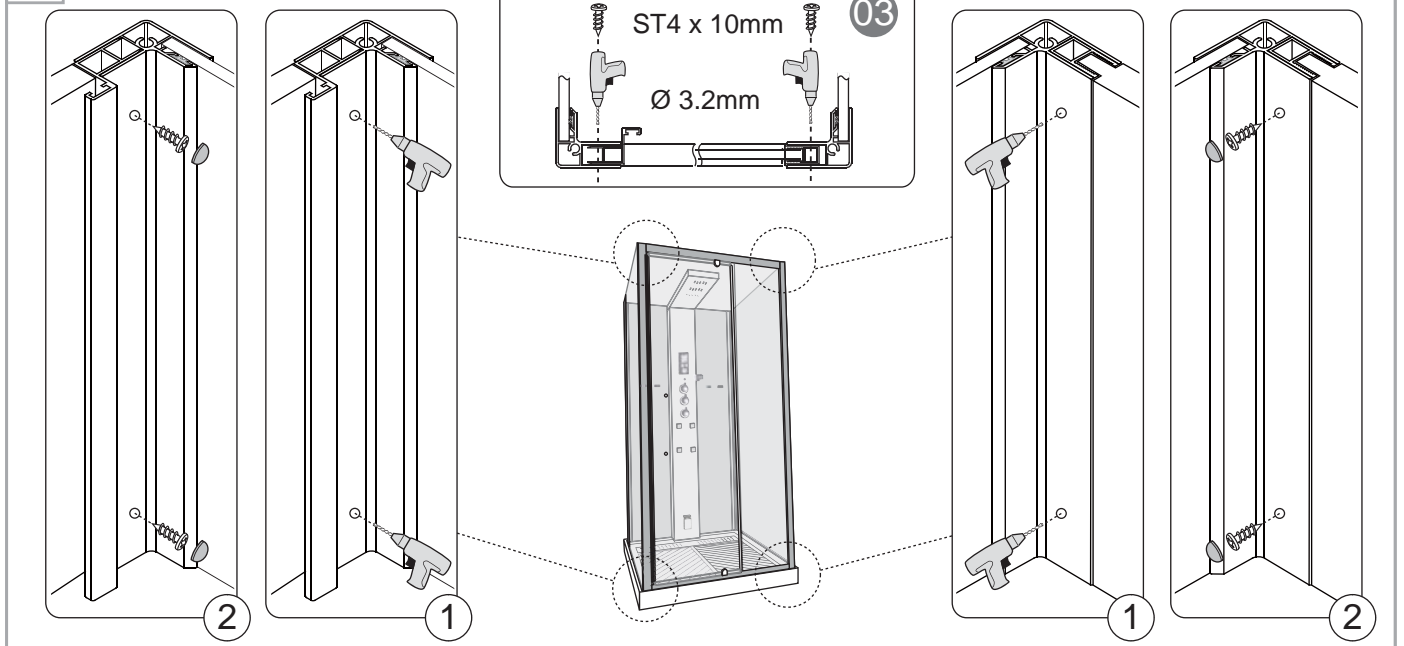

28

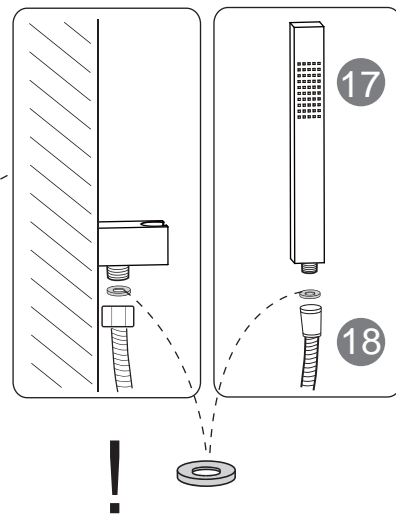
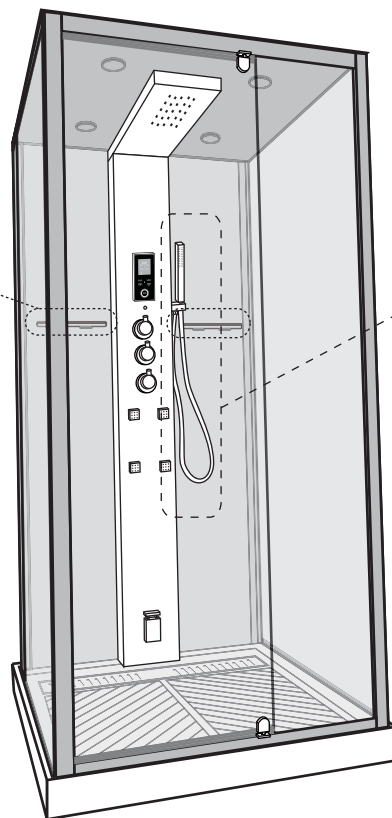
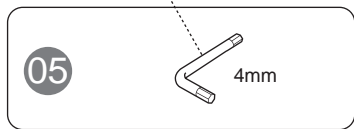
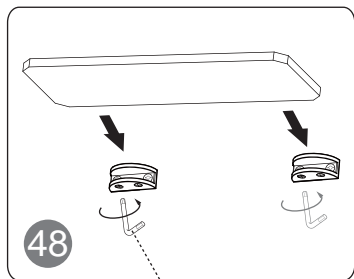

29

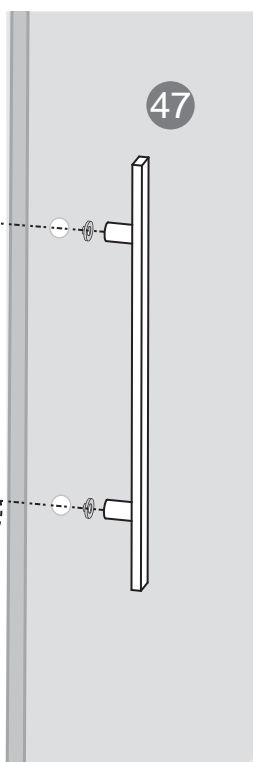
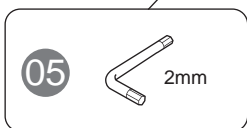
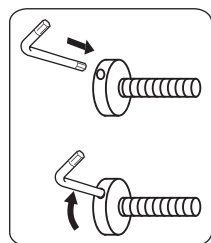

30

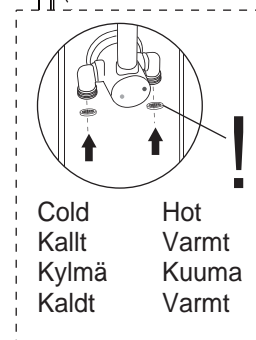
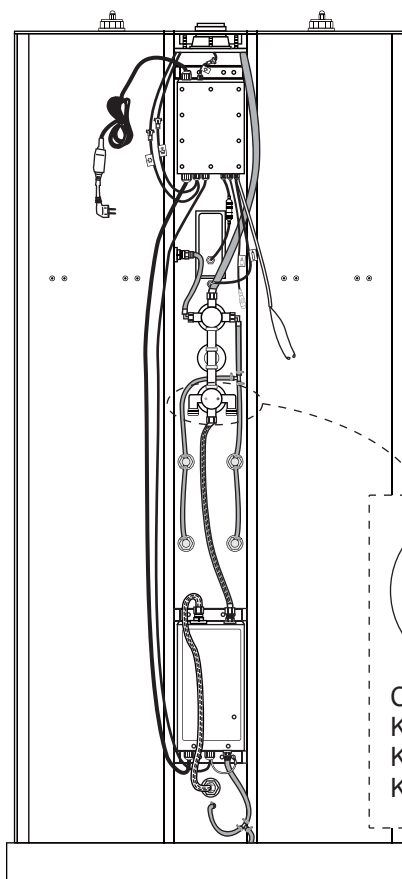

Cold  
Kallt  
Kylmä  
Kaldt

Hot  
Varmt  
Kuuma  
Varmt

## Technical Details / Tekniska detaljer / Tekniset osat / Tekniske detaljer

Voltage	220V -240V 50 /60Hz	Height	2120mm
Power	3.1KW	Inside Height	2000mm
Length	1000mm	Maximum Door Opening	500mm
Width	1000mm	Maximum Steam Temperature	50°C

## Electronic Connection / Elanslutning / Sähköliitäntä / Strömtilkobling

Caution: A ground-fault protector (earth-breaker) is required to be used with the steamer.

## Electrical Diagram / El-schema / Sähkökaava / Koblingsskjema for strøm

### CONNECTION BLUEPRINT OF STEAM SYSTEM

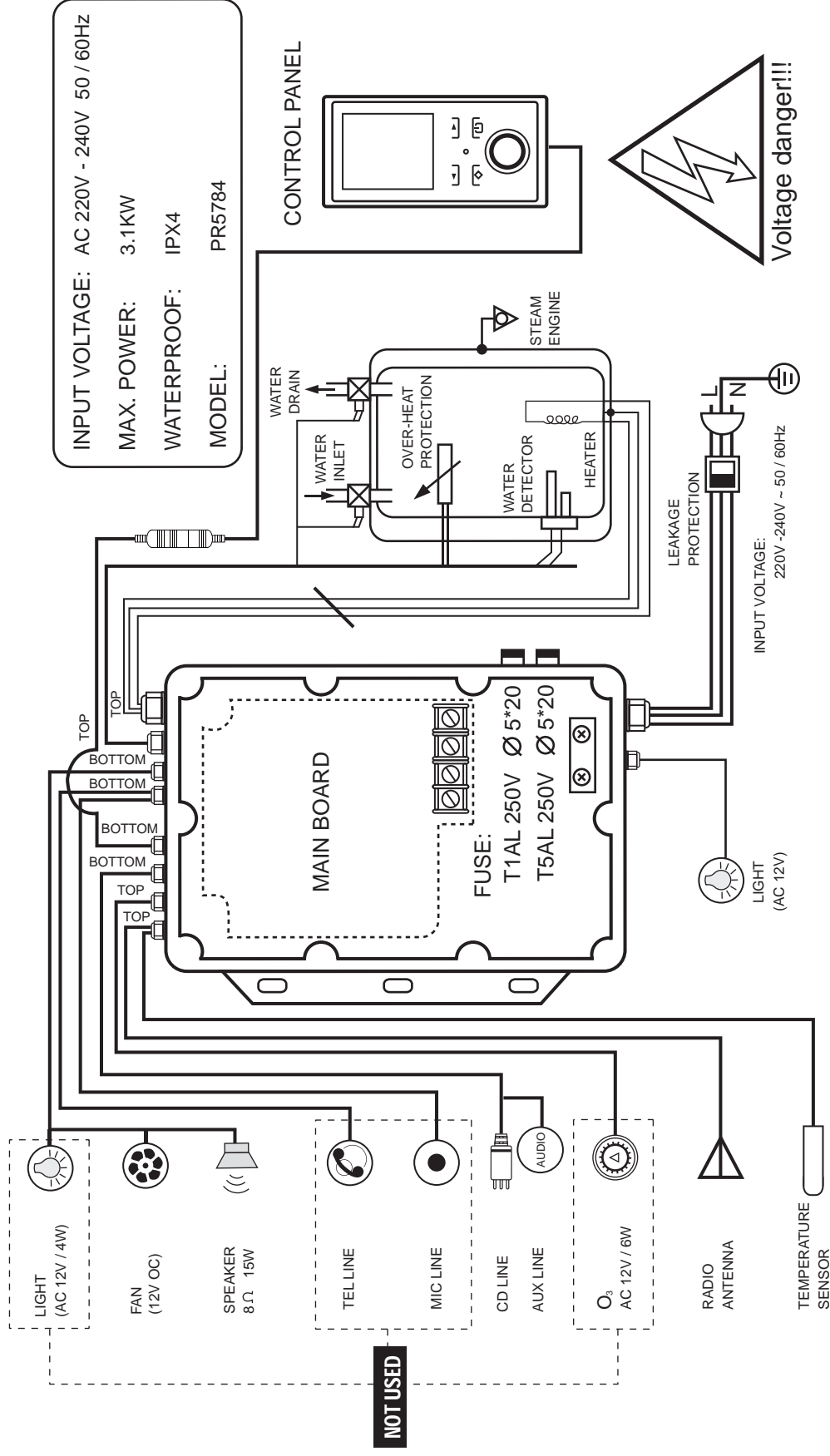



### WARNING / VARNING / VAROITUS / ADVARSEL:

- (GB)** Children should not use this appliance unsupervised. It is recommended that all children receive proper instructions and understand the hazards of improper use.
- (SE)** Barn under 15 år skall inte använda Ångduschen utan överensende av en vuxen person.
- (FI)** Alle 15 vuotiaiden lasten ei tule käyttää höyrysuihkun toimintoja ilman aikuisen tarkkailua.
- (NO)** Barn under 15 år skal ikke bruke steamdusjen uten oppsyn fra en voksen person.

### How to change remote control battery / Byte av batteri i fjärrkontrollen / Pariston vaihto kaukosäättimeen / Bytte av batteri i fjernkontrollen:

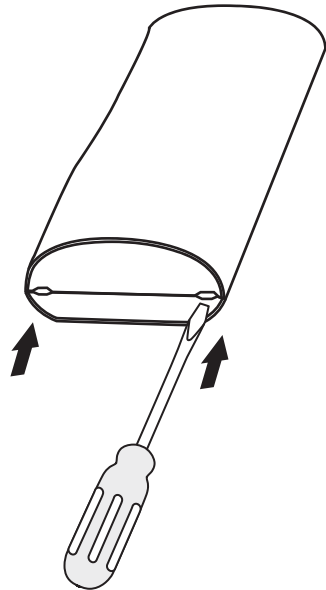

AAA 1.5V

AAA 1.5V

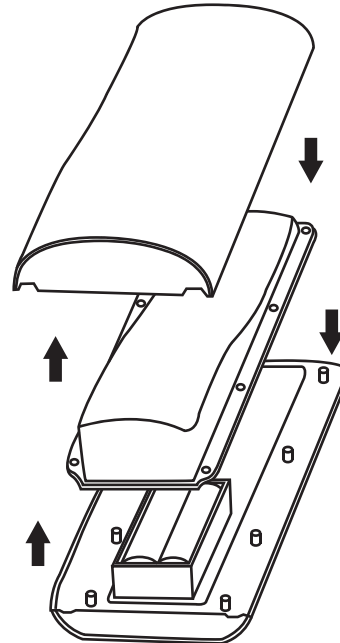

### Remote Control / Fjärrkontroll / Kaukosäädin / Fjernkontroll:

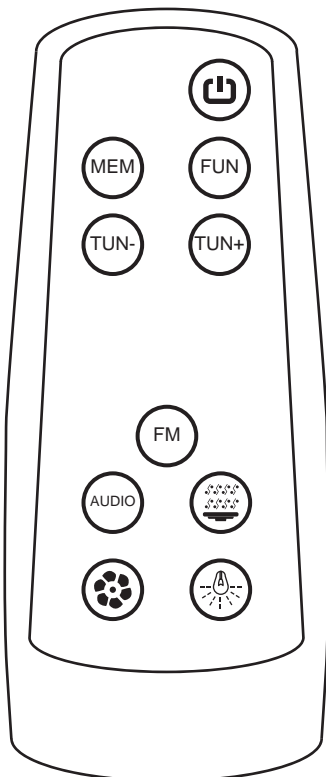

**(GB SE)**

- Power On / Off On/Off
- Frequency storage / select Stations väljare
- Function switch Funktionsväljare
- Adjusting minus Justering -
- Adjusting plus Justering +
- FM power switch FM On/Off
- AUX power switch AUX On/Off
- Steamer Ångdusch
- Fan Fläkt
- LED Light LED ljus

**(FI NO)**

- Päälle / Pois On/Off
- Kanavan valitsija Stasjonsvelger
- Toiminnanvalitsin Funksjonsvelger
- Säättö- Justering -
- Säättö + Justering +
- FM Päälle/Pois FM On/Off
- AUX Päälle/Pois AUX On/Off
- Höyrysuihku Steamdusj
- Tuuletin Vifte
- LED Valo LED lys

## Control Panel / Kontrollpanel / Ohjauspaneeli / Kontrollpanel:

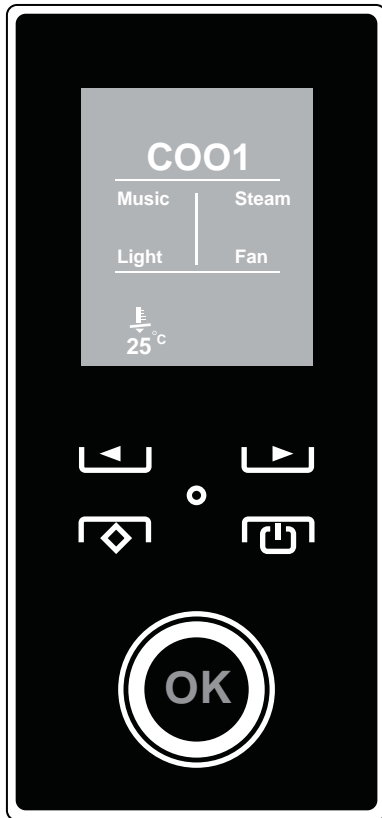

	<p><b>GB</b> Parameter setting decrease key + Parameter setting increase key  <b>SE</b> Genom att trycka på pilarna  kan man reglera en funktion upp eller ner.  <b>FI</b> Painamalla nuolista  voit säätää toimintoa ylös-tai alaspäin.  <b>NO</b> Ved å trykke på pilene  regulerer man funksjonene opp og ned.</p>
	<p><b>GB</b> Menu / function switch / station storage  <b>SE</b> Meny / Funksions brytare / stations väljare  <b>FI</b> Menu / Ohjelmiston katkaisija/ aseman valitsija  <b>NO</b> Meny / funksjonsbryter / funksjonsvelger</p>
	<p><b>GB</b> Power On / Off  <b>SE</b> On/Off  <b>FI</b> Päälle/Pois  <b>NO</b> On / Off</p>
	<p><b>GB</b> Remote control signal receiver  <b>SE</b> Fjärrkontrolls signalmottagare  <b>FI</b> Kaukosäätimen signaalinvastaanotin  <b>NO</b> Fjernkontrollens signalmottaker</p>
<b>OK</b>	<p><b>GB</b> Function confirmed  <b>SE</b> Funksions bekräftelse  <b>FI</b> Toiminnan vahvistus  <b>NO</b> Funksjonsbekreftelse</p>
	<p><b>GB</b> Rotating selection knob  <b>SE</b> Ratt  <b>FI</b> Ohjain  <b>NO</b> Ratt</p>

## Control Functions / Funktioner / Näppäintoiminnot / Funksjoner:

### ★ Power On / Off

**GB**

Press the power icon to ON the control panel. Press it again to turn off the control panel.

### ★ Rotating selection knob

Rotating the knob both right and left allows you to select different functions. You will see the cursor move. When the function is selected, press **OK** to select the function you want.

### ★ Fan

Move to **Fan**, press **OK** to start or turn on and off the fan. Pressing on the remote control also turns the fan on and off.

### ★ LED Light

Move to **Light**, press **OK** to start or turn on and off the light. Pressing on the remote control also turns the light on and off.

### ★ FM Radio

Move the cursor to **Music** and press **OK**, the FM radio will turn on. Press it a second time, it will go to AUX/CD. Press it one more time, then it will turn off the music system.

You can also use the buttons on the remote control.

When playing the radio, to select stations simply use the select buttons to browse through different channels.

To adjust the volume, press and hold the function button until you see the volume icon flashing. Then use the selection buttons to increase or decrease the volume.

Pressing the function button again, you will see the memory function to store the FM radio channels.

### ★ Steam System

To use the steamer system, move the cursor to **Steam** and press **OK**, the steamer should start to work. You can also use the button on the remote control.

It may take a few minutes for the steam to come out as the water takes time to heat.

This icon on the LCD screen, shows the current temperature in the steamer cabin.

To change the desired steam temperature, press and hold the function button until the temperature icon begins to flash. Use the selection buttons to increase or decrease the desired Celsius temperature. Press the function key again to switch to Fahrenheit setting.

Press the function key again for timer setting, you will see the timer icon  blink. Use the selection buttons   to adjust the desired time.

Do not forget to turn off the steamer function or the control panel when finishing your steam bath.

\*\*\* Remember, the function button  allows you to toggle between different settings where you can adjust as you like. If you do not make any adjustments, it will go back to default screen after few seconds.

SE

## ★ On/Off

Tryck på on/off-knappen  för att sätta på kontrollpanelen. Ett andra tryck stänger av den.

## ★ Ratt

Genom att vrida på ratten kan olika val göras. Man ser mellan parenteserna [  ] vilken funktion som kan väljas. När önskad funktion ses trycker man på **OK** för att bekräfta valet.

## ★ Fläkt



Vrid ratten tills **Fan** syns i parenteserna och tryck **OK** för att starta/stänga av fläkten. Genom att trycka på symbolen  på fjärrkontrollen kan fläkten startas eller stängas av.



## ★ LED Ljus



Vrid ratten tills **Light** syns i parenteserna och tryck **OK** för att starta/stänga av ljuset. Även genom att trycka på symbolen  på fjärrkontrollen kan ljuset tändas eller släckas.

## ★ FM Radio

Vrid ratten tills **Music** syns i parenteserna och tryck **OK** för att starta/stänga av radion. Genom att trycka en andra gång startar AUX/CD. Ytterligare ett tryck stänger av musiken.

Man kan även trycka direkt på resp. knapp på fjärrkontrollen.  

I Radio läget kan man välja kanal genom att trycka på  .

För att reglera volymen trycker man på knappen  tills volymsymbolen syns. Reglera därefter volymen med pilarna  .



Genom att trycka en andra gång på  kommer radiokanalen att memoreras.

## ★ Ångsystem

För att starta ånggeneratorn vrid ratten tills **Steam** syns mellan parenteserna och tryck sedan **OK**. Man kan även trycka direkt på symbolen  på fjärrkontrollen.

Det tar 2-3 minuter innan ånggeneratorn blivit så var, att den ger ånga genom ångmunstycket.

Temperaturen i Ångduschen visas på kontrollpanelen  25°C.

För att justera temperaturen i Ångduschen tryck och håll på funktionssymbolen  tills temeratsymbolen börjar blinka. Genom att trycka på pilarna   kan temperaturen justeras. Genom ytterligare ett tryck på funktionsknappen kan man växla mellan Celsius och Fahrenheit. OBS! Max temperaturen i bastun ligger på c:a 42 grader beroende på omgivande temperatur.

Genom att ytterligare en gång trycka på funktionsknappen syns  och kan man ställa in timer på ånggeneratorn.

Kom ihåg att stänga ångfunktionen när man bastat färdigt.

\*\*\* Tänk på att funktionsknappen  tillåter att man hoppar mellan olika funktioner som man kan justera enligt önskemål med pil-knapparna. När displayen inte varit aktiv under några sekunder återgår den till viloläge.

FI



## ★ Virta Päälle/Pois

Paina päälle/pois nappia  käynnistääksesi näppäimistön. Toinen painallus sammuttaa toiminnot.

## ★ Ohjain

Ohjainta kääntämällä voit tehdä eri valintoja. Sulkujen sisältä [  ] näet minkä toiminnan voi valita. Kun toivottu toiminta tulee esille paina **OK** nappulaa vahvistaaksesi valintasi.

## ★ Tuuletin

Valitse suluista [  ] **Fan**, paina **OK** käynnistääksesi tai sulkeaksesi tuuletin. Painamalla  kaukosäätimestä, voidaan myös tuuletin käynnistää tai sulkea.

## ★ LED Valo

Siirrä suluista [  ] **Light**, paina **OK** valo päälle tai pois. Painamalla  kaukosäätimestä saat myös valotoiminnan päälle/pois.

## ★ FM Radio

Valitse sulusta [ ] Music ja paina OK , FM radio käynnistyy. Painallus toistamiseen, saat AUX/CD toiminnan. Painallus vielä kertaalleen sulkee musiikki toiminnon.

Voit myös käyttää kaukosäätimen.   nappeja.

Radiosta voit vaihtaa kanavat painamalla näppäimistä.   .

Äänensäädön löydät painamalla nappulaa  kunnes näet ääniikonin. Säädä äänen voimakkuus nuolista   .





Painamalla toimintanappulaa  uudelleen, radiokanavat jäävät muistiin.



## ★ Höyrytoiminta

Päästäksesi höyrytoimintaan käännä ohjain [ ] Steam ja paina OK , höyrykehitin käynnistyy. Voit myös painaa  kaukosäätimen nappulaa käynnistääksesi toiminnan.

Höyryrnehitys voi kestää muutamia minutteja. (Vesi kuumenee ja muuttuu höyryksi)

Höyrysuikun lämpötilan näyttö ohjauspaneelissa  25 °C .

Säätääksesi höyrysuikun lämpötilaa paina toimintanappulaa  niin kauan kunnes lämpötila ikoni alkaa vilkkumaan.. Painamalla nuolista   voidaan lämpötilaa säätää. Painamalla  uudelleen voit vaihtaa Celsiuksesta Fahrenheitiin. Huom! Max lämpötila höyrysuikussa noin 42 astetta riippuen ympäristön lämpötilasta

Ajastaaksesi höyrysuihku paina uudelleen toimintanappulaa, ajastusikoni  45 vilkkuu. Valitsemalla nuolista   valitset ajan.

Muista kytkeä höyrysuihku pois päältä kun olet kylpenyt valmiiksi.

\*\*\* Muista että toimintanappi  antaa mahdollisuuden eri valintojen välille jotka voidaan säätää nuolien avulla. Kun näyttö ei ole ollut aktiivinen palautuu se muutaman sekunnin sisällä lepoasetukseen.

## ★ On / Off

Trykk på on/Off knappen  for å skru på kontrollpanelet. Trykk en gang til for å skru det av.

## ★ Funksjonsvelger

Ved å vri på funksjonsvelgeren kan du gjøre forskjellige valg. Hvilken funksjon man har valgt, ser man mellom parentesene [ ] . Når ønsket funksjon vises, trykker man på OK for å bekrefte valget.

## ★ Vifte

Vri rattet til **Fan** vises i parentesene og trykk OK for å starte/stoppe viften. Ved å trykke på symbolet  på fjernkontrollen, kan viften startes eller stoppes.

## ★ LED-lys



Vri rattet til **Light** vises i parentesene og trykk OK for å slå på eller av lyset. Lyset kan også tennes eller slukkes ved å trykke på  .

## ★ FM Radio

Vri rattet til **Music** vises i parentesene og trykk OK for å slå på eller av radioen. Ved å trykke en gang til starter AUX/CD. Ytterligere ett trykk slår av musikken.

Man kan også trykke direkte på respektive knapp på fjernkontrollen.  

Når Radio er valgt, kan man velge kanal ved å trykke på   .

For å regulere volumet trykker man på  knappen til volum symbolet vises. Reguler deretter volumet med pilene   .



ved å trykke en gang til på  vil radiokanalen bli lagret.

## ★ Steamsystem

For å starte steamgeneratoren vris rattet til **Steam** vises mellom parentesene. Trykk så OK . Man kan også trykke direkte på symbolet  på fjernkontrollen.

Det tar 2-3 minutter før steamgeneratoren har blitt så varm at den gir damp i steam-munnstykket.

Temperaturen i steamdusjen vises på kontrollpanelet  25 °C .

For å justere temperaturen i steamdusjen trykk og hold på funksjonssymbolet  til temperatursymbolet begynner å blinke. Ved å trykke på pilene   kan temperaturen justeres. Ved ytterligere et trykk på funksjonsknappen kan man veksle mellom Celsius og Fahrenheit. OBS! Maks temperatur i steamdusjen ligger på ca. 42 grader avhengig av romtemperatur.

Ved ytterligere ett trykk på funksjonsknappen vises  45 og man kan stille inn timer på steamgeneratoren.

Husk å stenge steamgeneratoren når du er ferdig med å bruke steamdusjen.

\*\*\* Husk at funksjonsknappen  tillater at man hopper mellom ulike funksjoner. Disse kan man justere etter ønske med pilknappene. Når displayet ikke har vært aktivt i noen sekunder, går den tilbake til hvileposisjon

NO

## System Reset / Återställning / Palautus tehdasasetukseen / Tilbakestilling

- (GB)** Turn off the steamer system and unplug the power cord from the outlet. Wait for 10 minutes for the system to reset. Then plug the power cord back into the outlet and turn the power on.
- (SE)** Stäng av ångbastun på kontrollpanelen. Bryt strömmen till ångduschen genom att dra ut stikkontakten. Låt ångbastun vara strömlös i minst 10 min. Sätt därefter i kontakten och starta ångbastun igen.
- (FI)** Sammuta höyrystuohu ohjauspaneelista. Katkaise virta höyrystuohkuun irrottamalla pistoke seinästä. Anna höyrystuohkun olla ilman virtaa vähintään 10 minuuttia. Laita pistoke paikoilleen ja käynnistä höyrystuohku.
- (NO)** Slå av steamdusjen på kontrollpanelet. Slå av strømmen til steamdusjen ved å dra ut stikkkontakten. La steamdusjen være strømløs i minst 10 min. Sett deretter i kontakten og start steamdusjen igjen.

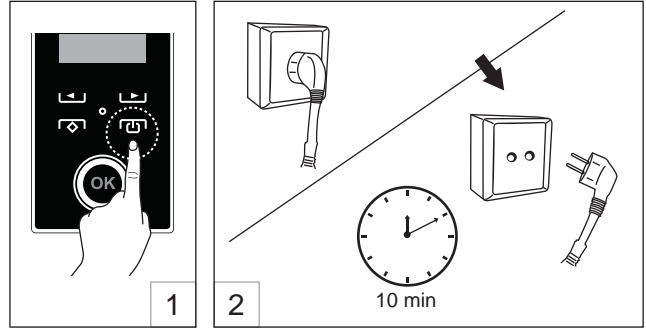

## Steam generator / Ånggenerator / Höyrykehitin / Steamgenerator

- (GB)** There always should be a flow of (cold) water into the steam generator box. To check this, you can make sure that the water hose into the steam generator box is under pressure.
- (SE)** Det ska alltid finnas ett flöde av kallt vatten till ånggeneratorm. För att kontrollera detta kan man känna på anslutningsslangen till ånggeneratorm att det är tryck i den slangen.
- (FI)** Höyrykehittimeen on aina virrattava kylmää vettä. Tarkistaaksesi tämän voidaan höyrykehittimeen menevää vesiliitosputkea tunnustella onko putkessa painetta. (putki kylmä).
- (NO)** Det skal alltid være et trykk på kaldvannet til steamgeneratorm. For å kontrollere dette kan man kjenne på tilkoblingsslangen til steamgeneratorm for å kjenne at det er trykk på slangen.

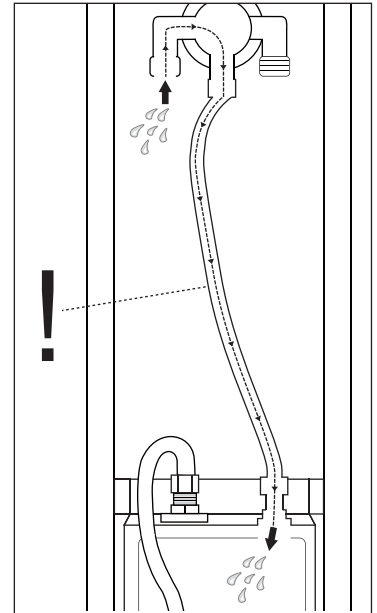

## Temperature sensor malfunction / Temperatursensorns function / Lämpötilasensorin toiminta / Termostatfunksjon

- (GB)** When the circuit for the temperature sensor is open or short, the steam generator will not work and sound an alarm. Please shutoff the steam system and check that the temperature sensor cable is not damaged.
- (SE)** Om temperatursensorn till inte är ansluten eller om det blivit kortslutning kommer inte ånggeneratorm att fungera utan ett alarm ljuder. Stäng av ångduschen och kontrollera temperatursensorns kabel.
- (FI)** Jos lämpötilasensoria ei ole kytketty tai siinä on oikosulku, ei höyrykehitin toimi vaan silloin kuuluu hälytys. Sulje höyrytoiminta sekä höyrykaappi ja tarkista lämpötilasensorin liitäntä.
- (NO)** Hvis termostaten ikke er tilkoblet eller den er kortsluttet kommer ikke steamdusjen til å fungere. Du vil høre en alarm.

## Circuit Breaker / Jordefelsbrytaren / Vikavirtasuoja / Jordfeilbryter

- (GB)** Turn off the steamer system and unplug the power from the outlet. Check to see that the fuse in the circuit breaker is still working. Otherwise, the fuse needs to be replaced.
- (SE)** Kontrollera regelbundet att jordefelsbrytaren fungera med testknappen på densamma.
- (FI)** Tarkista vikavirtasuojan toiminta säännöllisesti siinä olevasta testinappulasta.
- (NO)** Kontroller regelmessig at jordfeilbryteren fungerer ved å trykke på testknappen på denne.

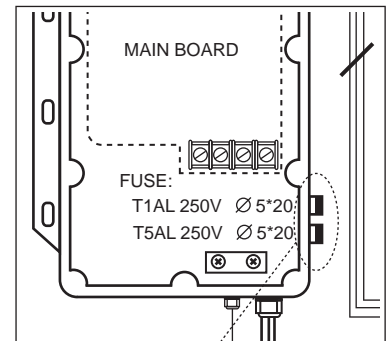

**!**  
**FUSE**



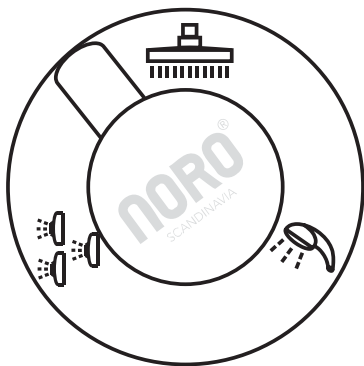

**GB Function Switch knob:**



Tropical Rain



Massage Nozzles



Hand Shower

**SE Funktion vredet/knopp:**



Tropiskt regn



Massage jets



Handdusch

**NO Funksjons knott/bryter:**



Tropisk regn



Massasje dyser



Hånddusj

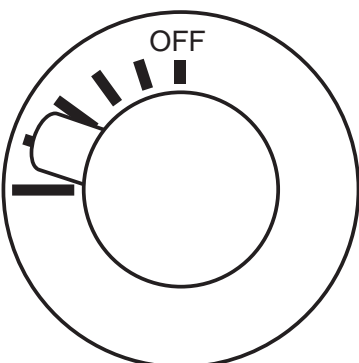

**GB Water-pressure Control Switch knob**

**SE Vredet/knopp för inställning av vattentrycket**

**NO Knott/bryter for innstilling av vanntrykk**

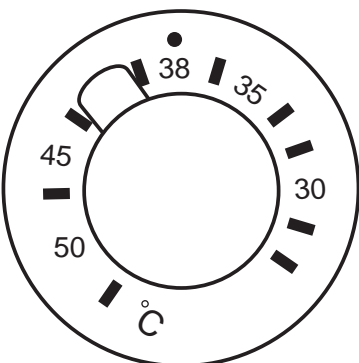

**GB Water Temperature Knob:**

This is a thermostatic mixer, which regulates the water temperature at a desired setting to avoid injury during use. For water temperature above 38 degrees, user must press down on the small knob and turn left to receive higher temperature water.

**SE Vredet/knopp för inställning av temperaturen på vattnet:**

Detta är en termostatblandare som reglerar vattentemperaturen för önskad inställning för att undvika skador under användning. För vatten temperaturer över 38 grader, måste användaren trycka ner på den lilla knappen och vrida mot vänster för att nå en högre temperatur på vattnet.

**NO Knott/bryter for innstilling av temperatur på vannet:**

Dette er ett termostatblandebatteri som regulerer vanntemperaturen etter ønsket innstilling for å unngå skader under bruk. For vanntemperaturer over 38 grader, må brukeren trykke ned på den lille knotten og vri mot venstre for å oppnå høyere temperatur på vannet.

- GB** Clean often with the use of ordinary detergents or common bathroom cleaning products to remove mold and mildew stains. Environmentally-friendly cleaning products are recommended.

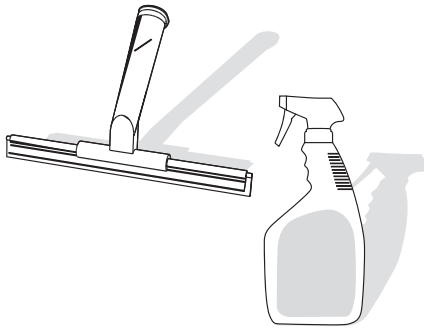

Avoid using steel wool or "Scotch Brite" products. Be careful when using cleaning products that contain hydrochloric acid, sulfuric acid, or caustic soda. Dissolvents like acetone, diluting agents or trichlorethene are not recommended to use when cleaning.

Simply scrape the shower glass panels and tray with "Squeegee" after cleaning with detergents.

Try to keep bathroom area well ventilated to prevent condensation and mold.

Hinges on the doors should be lubricated once or twice a year to keep a smooth turning of the door.

- 
- SE** Rengör ofta med hjälp av tvättmedel eller rengöringsmedel för badrum produkter, för att ta bort mögel och fläckar. Miljövänliga rengöringsmedel rekommenderas.

Undvik att använda stålull eller "Scotch Brite"-produkter. Var försiktig när du använder rengöringsmedel som innehåller saltsyra, svavelsyra eller kaustiksoda. Rengöringsmedel som innehåller aceton, trikloretan och / eller lösningsmedel rekommenderas inte att använda för rengöring.

Ta en "gummiskrapa" för att torka av glas panelerna på duschen och duschkar, efter rengöring med tvättmedel / rengöringsmedel.

God ventilation i badrummet kommer att bidra till att förebygga kondens och utveckling av mögel.

Gångjärn på dörrar bör smörjas en eller två gånger per år för att behålla en jämn / bra rörelse på dörren.

- 
- NO** Rengjør ofte med bruk av vanlige vaskemidler eller rengjøringsprodukter beregnet for baderomsprodukter, for å fjerne eventuell mugg og flekker. Miljøvennlige rengjøringsmidler anbefales.

Unngå å bruke stålull eller "Scotch Brite" produkter. Vær forsiktig når du bruker rengjøringsmidler som inneholder saltsyre, svovelsyre, eller kaustisk soda. Rengjøringsprodukter som inneholder aceton, trikloretan og/eller fortynnende stoffer er ikke anbefalt å bruke ved rengjøring.

Benytt en "gumminal" til å tørke av dusjens glass paneler og kar med etter rengjøring med vaskemiddel/rengjøringsprodukter.

God ventilasjon på baderommet vil være med å hindre kondens og muggdannelse.

Hengsler på dørene skal smøres en eller to ganger i året, for å opprettholde en jevn/god bevegelse på døren.

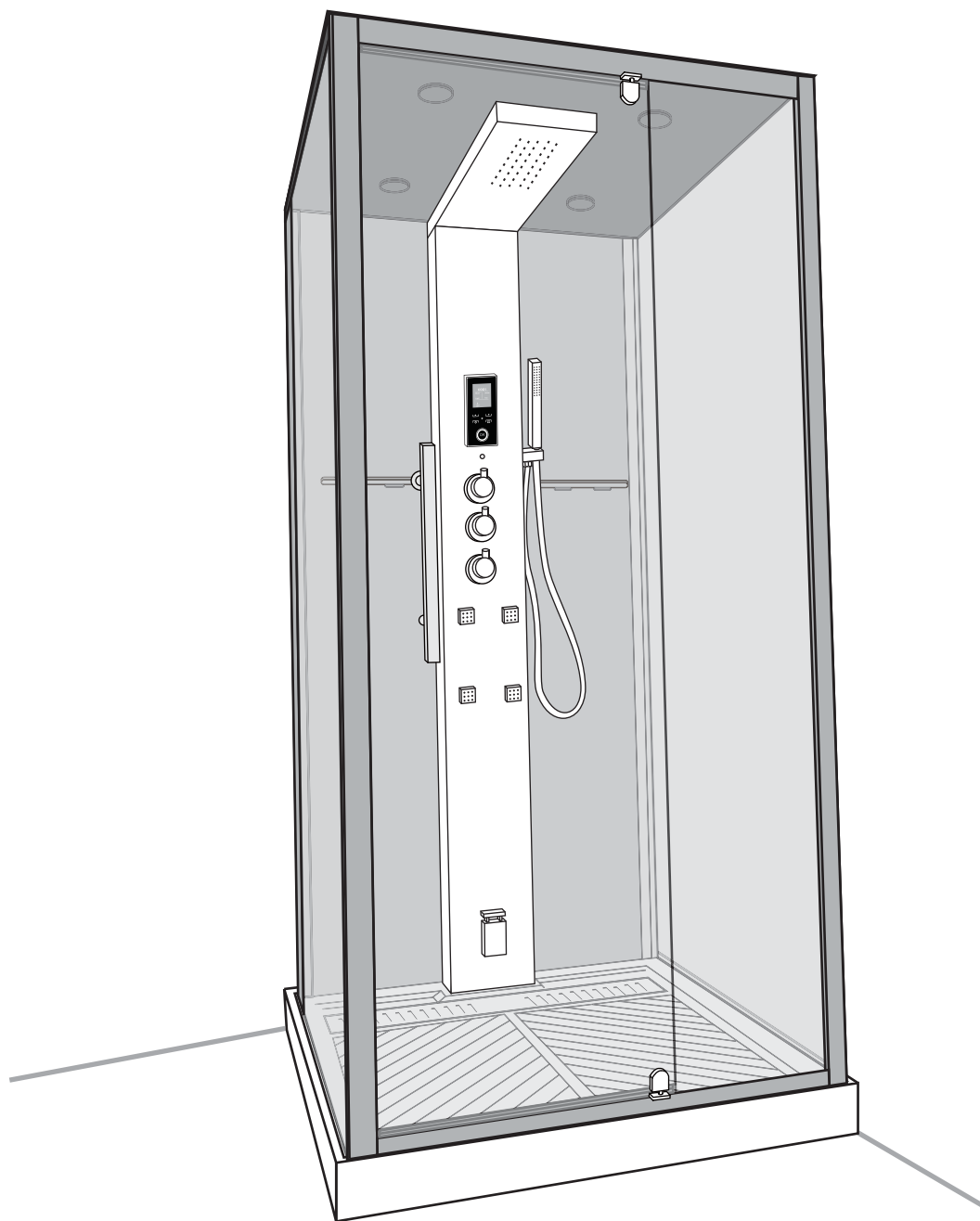

# AVANTI

## Noro Scandinavia

035 166430 **SE**  
info@noro.se

020 7435740 **FI**  
info@norokylpyhuone.fi

692 36170 **NO**  
info@noro.se

070 252822 **DK**  
info@noro.se

Ver.001