

ASSEMBLY MANUAL

Lyfco®

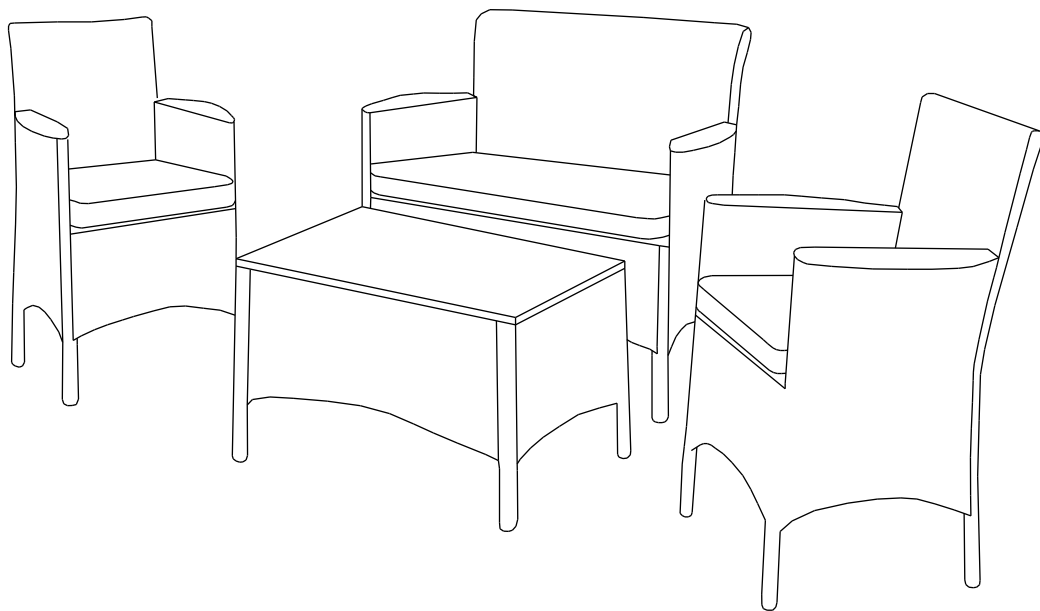

SKU: 166-1-6

MODEL NAME: Fjällbacka

Konsumentkontakt
Arc E-commerce AB
Box 3124
13603 Haninge

Attention! Please note that at first all screws should be inserted slightly by hand! Turn 2-3 times so that the screw grips on its own and connects all elements loosely. The screws must only be driven in tightly when all elements are connected with each other in this way. Otherwise the setup won't be possible. Only by driving them in tightly afterwards, small deviations of the borehole or the welded joints, which always occur with handcrafted products, can be compensated.

Notes on an optimized assembly:

Before you completely tighten the screws, check carefully all the screws and tighten them (only) to the extent that the product remains (especially chairs or loungers) still under load. If you are sure that your product can withstand load, place it on a solid, level ground and put some weight on it, please carefully and always with cushions. The various components can then align with each other. Then tighten completely the screws. Thus you achieve an optimal alignment of the product and prevent wobbling. Don't sit, find

Your new product was made by hand. Slightly irregularities are rather seen as a quality attribute than as a reason for complaints.

Tip: Always fully insert the hex key inside designated notch of screw.



If you don't do that and slip out of the screw, the screw will suffer damage and it can cause the screw head to become round inside you won't be able to find grip with the hex key anymore!



✘ DONT'S

Don't use this product if parts are missing, damaged or worn down.

Don't use any electronic tools to set up these product. The high energy of these electronic tools will cause screw overtighten and therefore they won't grip.

Don't overtighten screws or bolts. Only tighten the screws entirely after the product is completely set up. You shouldn't sit or stand on it.

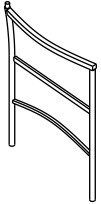
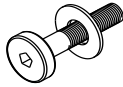
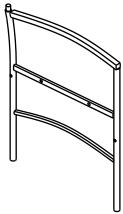
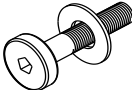
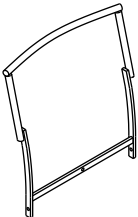
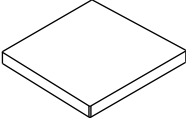
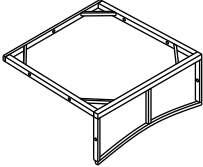
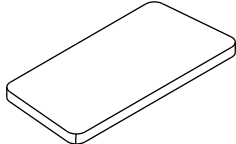
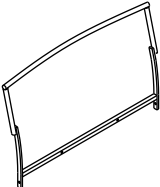
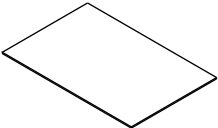
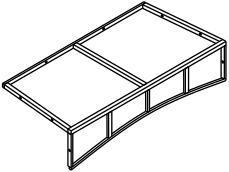
Don't let your product stand in the rain. Protect it from weather impacts. In times of freeze and over the winter, we suggest you to store the product in a covered dry place.

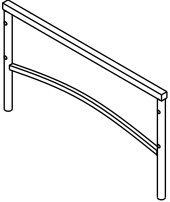
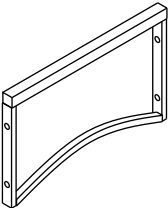
<u>Component</u>			<u>Hardware</u>			
A		6pcs	1	M6 x 40		12pcs
B		6pcs	2	M6 x 30		24pcs
C		2pcs	3	Seat Cushion		2pcs
D		2pcs	4	Bench Cushion		1pc
E		1pc	5	Table Glass		1pc
F		1pc	6	Allen key		1pc
G		2pcs				
H		2pcs				

STEP 1 (Single Chair Assembly)

Connect Right Frame (A) & Seat Frame (D) with Bolt (1),(2) & Allen key

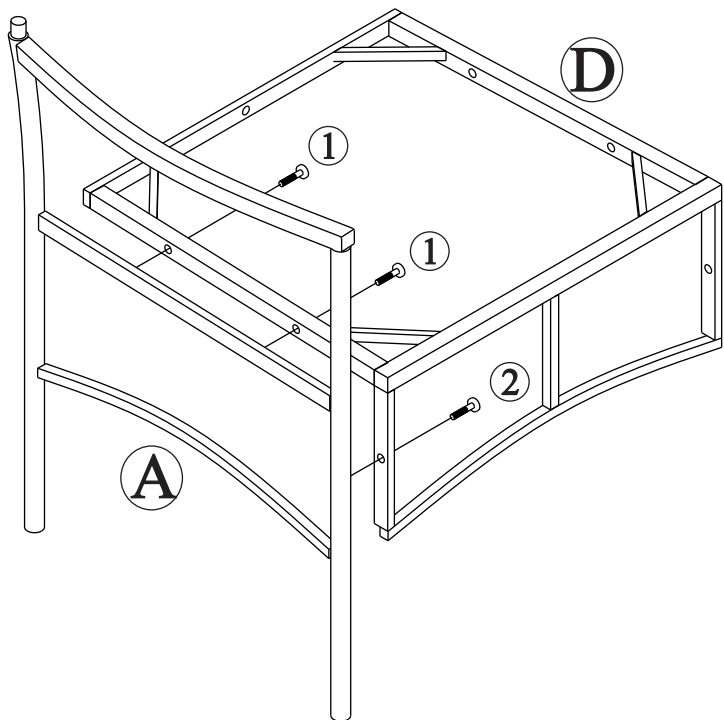

STEP 2

Connect part from STEP 1 & Left Frame (B) with Bolt (1),(2) & Allen key

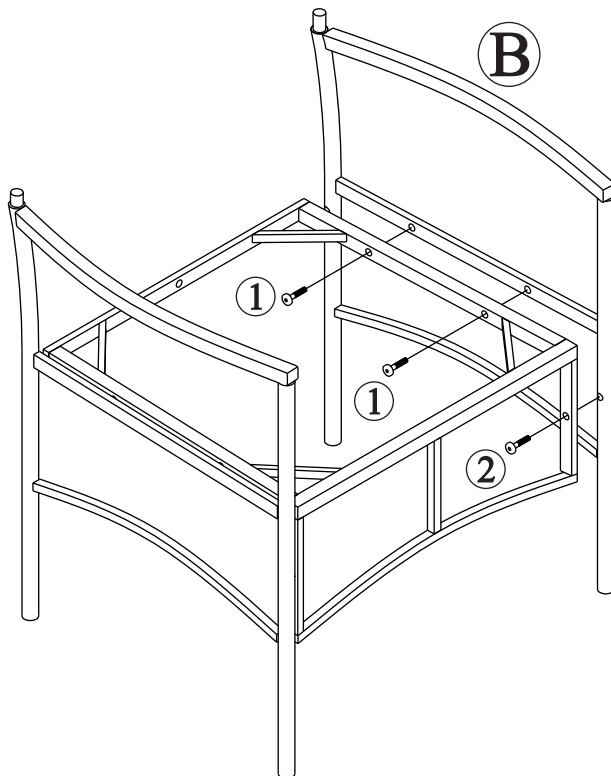

STEP 3

Connect part from STEP 2 & Back Frame (C)

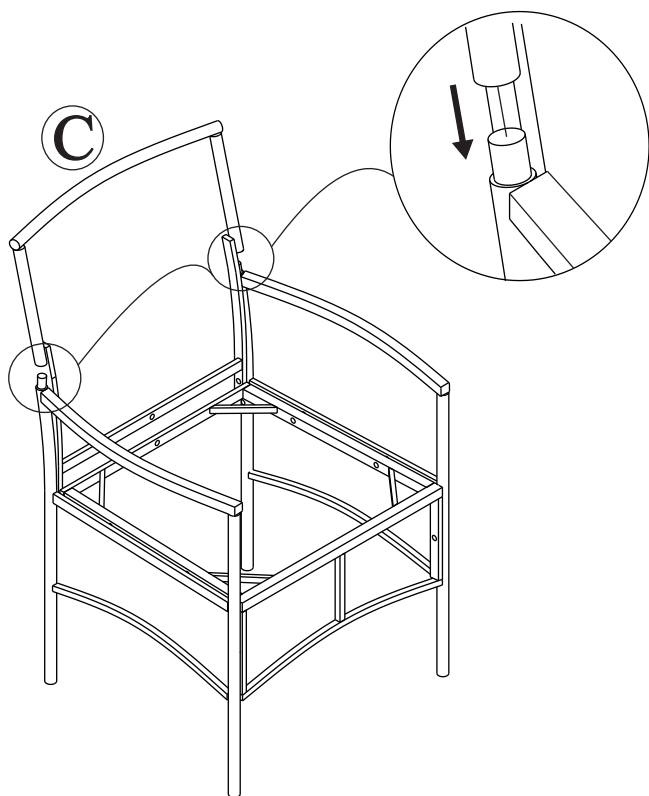

STEP 4

Connect part from STEP 3 with Bolt (2) & Allen key

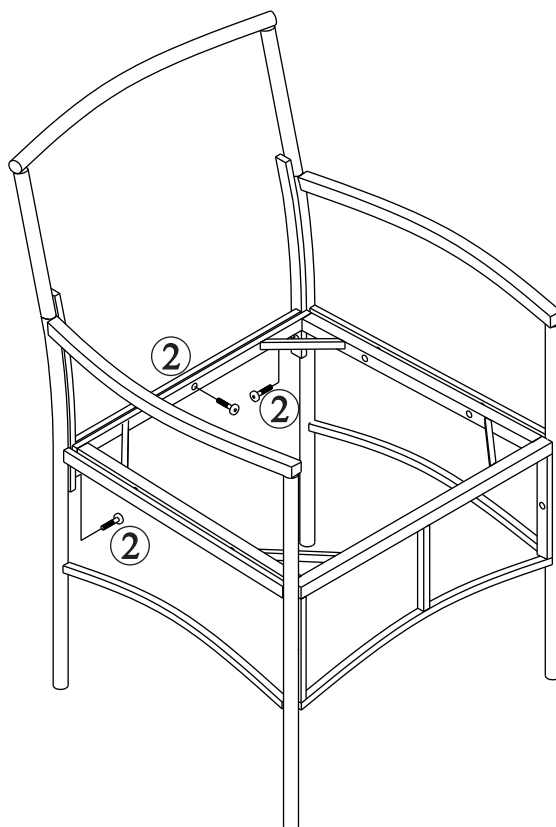

STEP 5

Put on Seat Cushion (3) to complete Single Chair

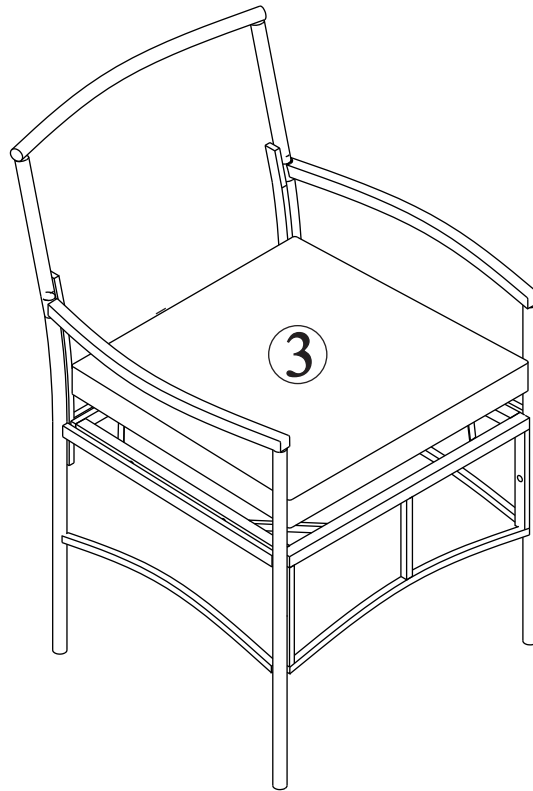

STEP 6

Connect Right Frame (A), Bench Seat Frame (F) with Bolt (1),(2) & Allen key.

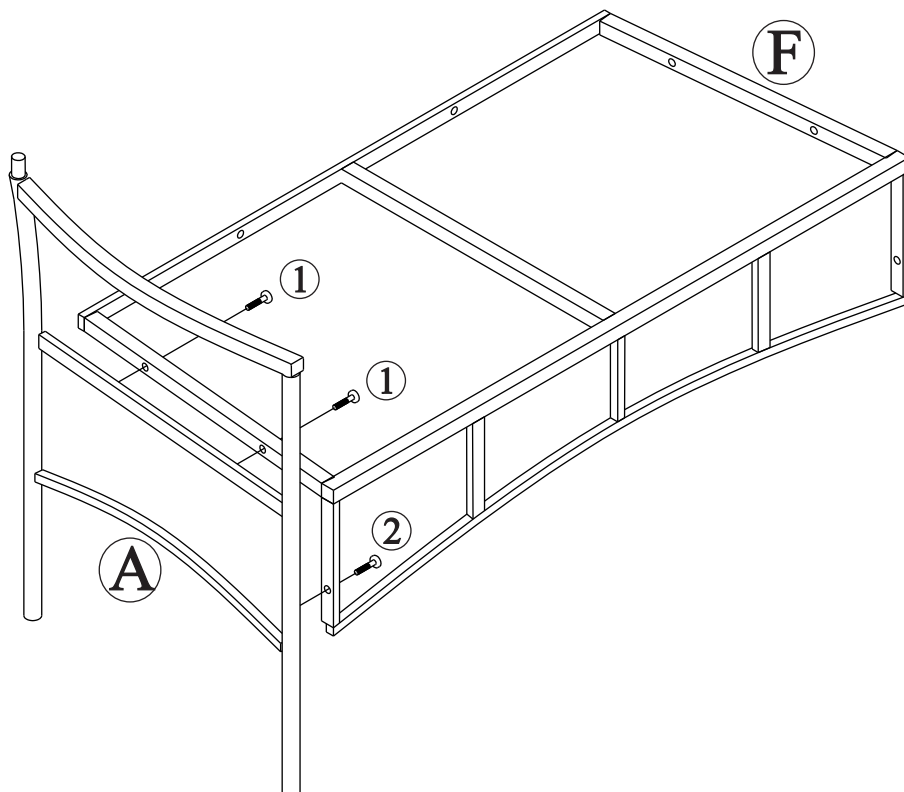

STEP 7

Connect part from STEP 6, Left Frame (B) with Bolt (1),(2) & Allen key.

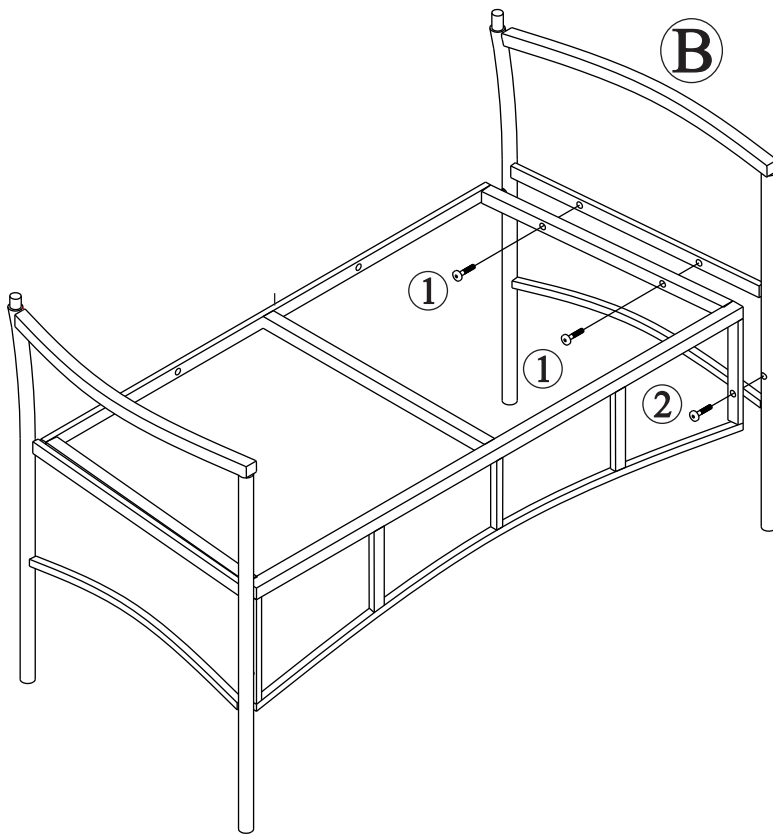

STEP 8

Connect part from STEP 7, Bench Back Frame (E).

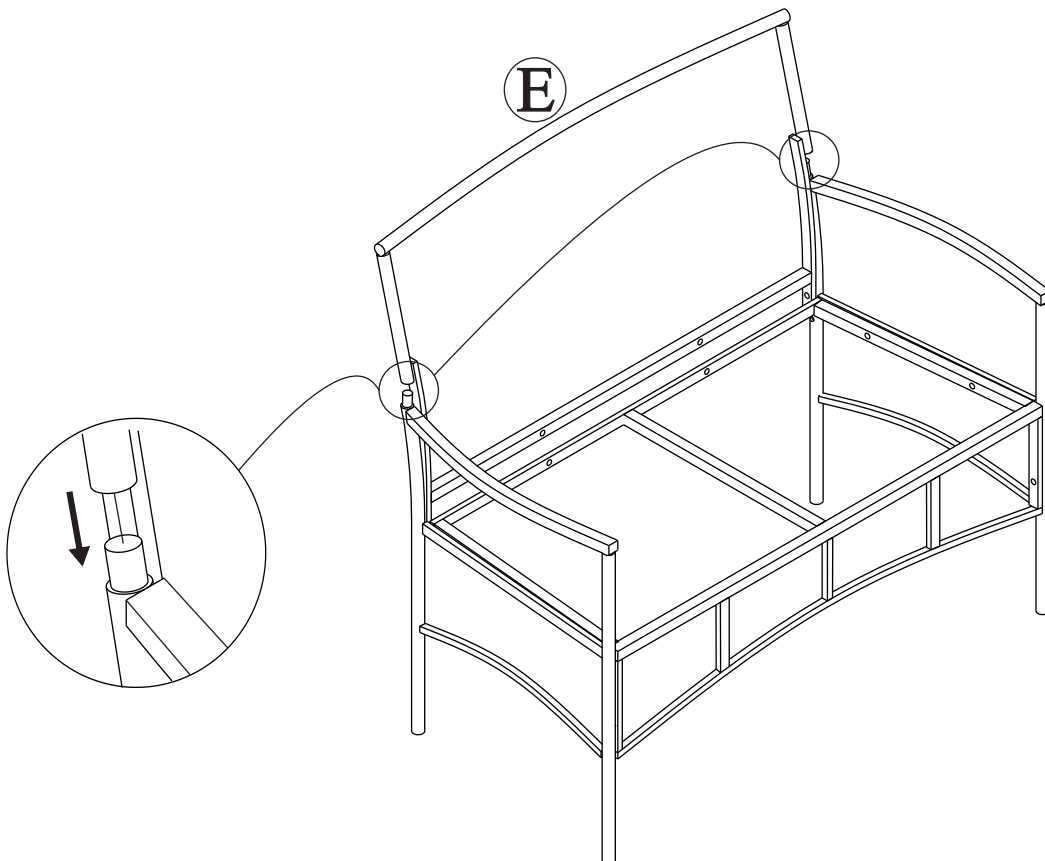

STEP 9

Connect part from STEP 8 with Bolt (2) & Allen key.

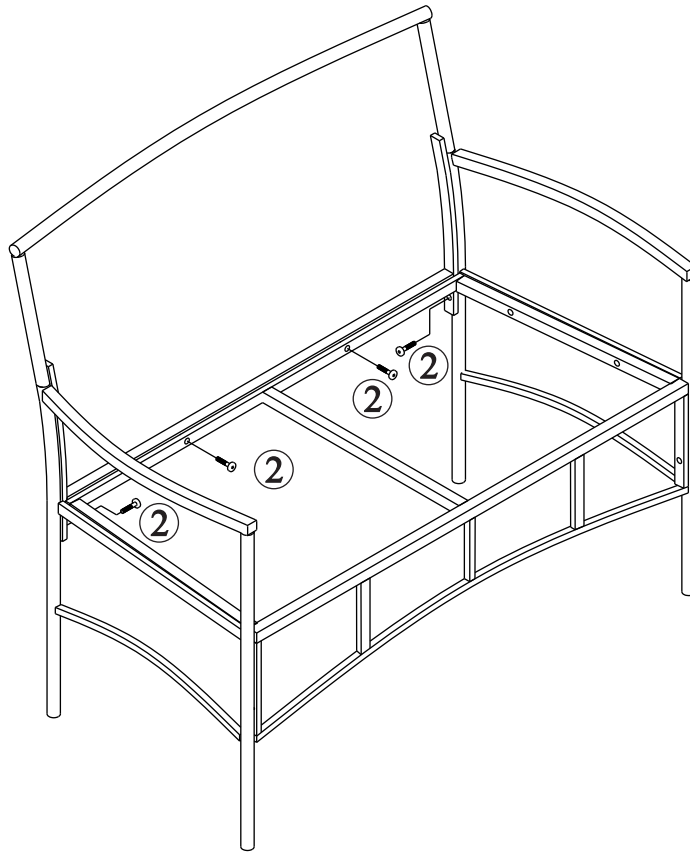

STEP 10

Put on Bench Cushion (4) to complete Bench.

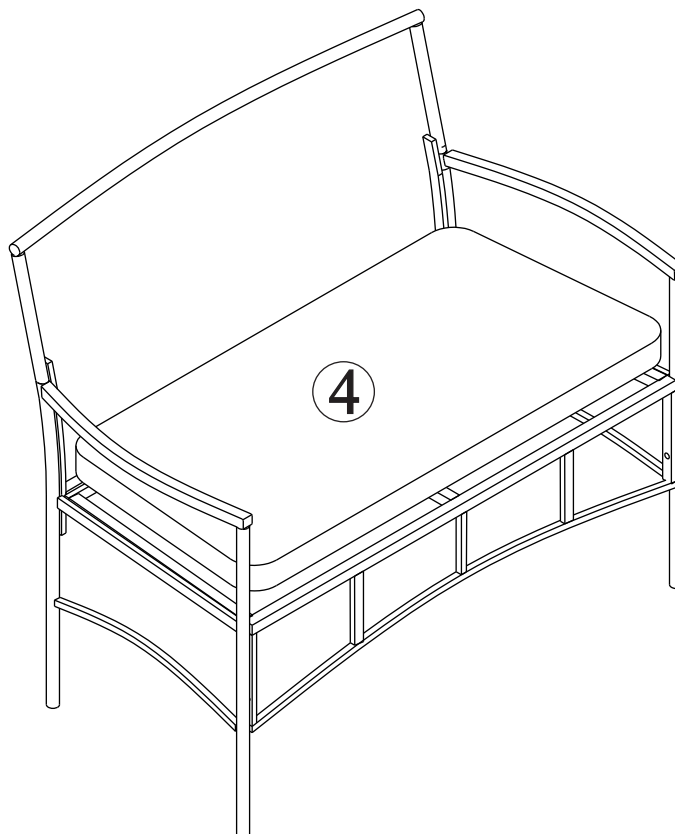

STEP 11

Connect Table Leg (G), Table Side Frame (H) with Bolt (2) & Allen key.

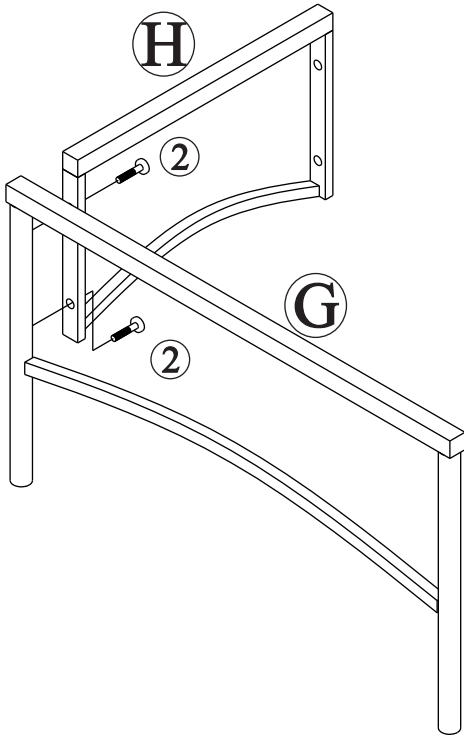

STEP 12

Connect part from STEP 11, Table Leg (G) with Bolt (2) & Allen key.

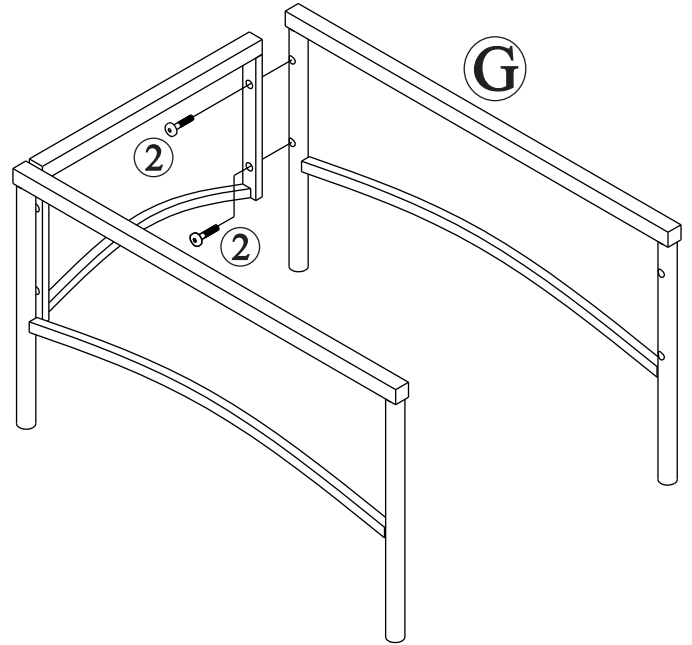

STEP 13

Connect part from STEP 12, Table Side Frame (H) with Bolt (2) & Allen key.

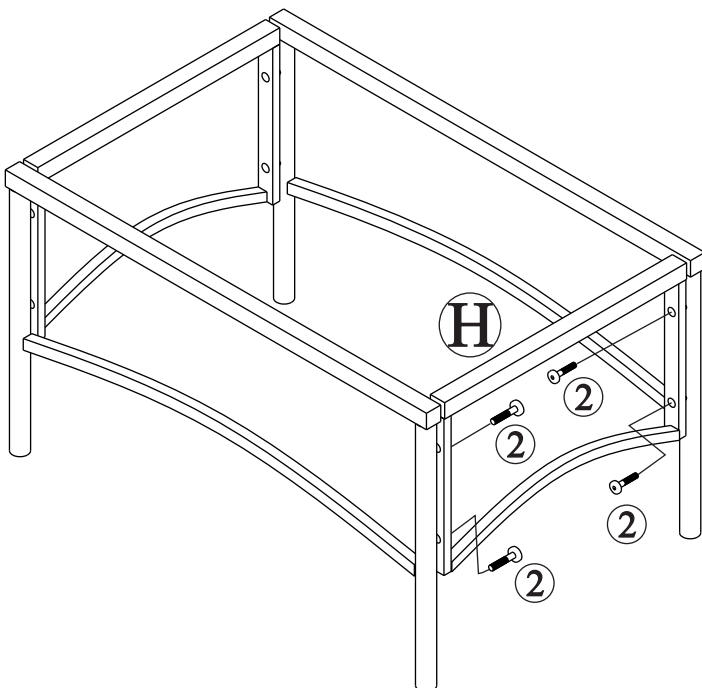

STEP 14

Put on Table Glass (5) to complete the Table.

