

# USER MANUAL

Compressor Refrigerator

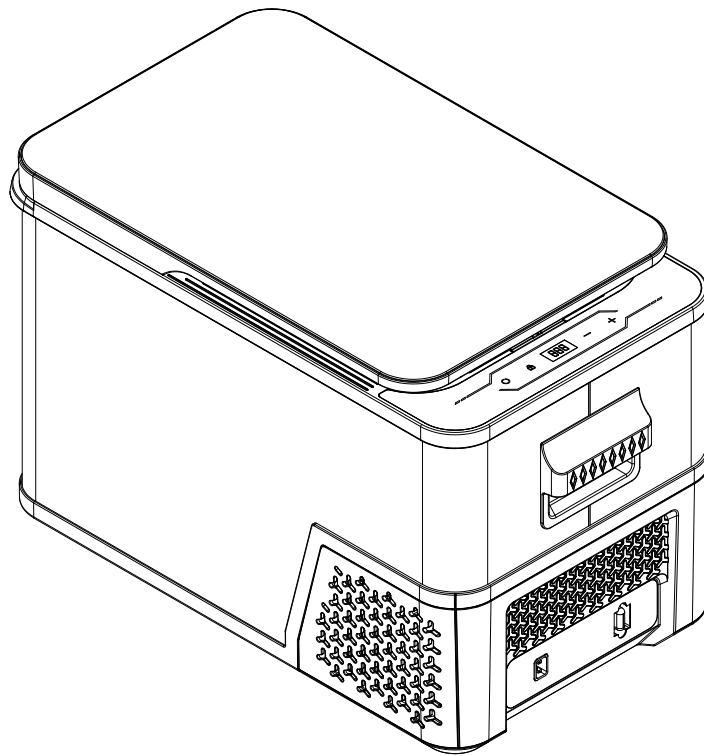

MODEL:CB30S

**WARNING:**

1. This appliance is not intended for use by persons (including children) with reduced physical, sensory or mental capabilities, or lack of experience and knowledge, unless they have been given supervision or instruction concerning use of the appliance by a person responsible for their safety.
2. Children should be supervised to ensure that they do not play with the appliance.
3. This appliance can be used by children aged from 8 years and above and persons with reduced physical, sensory or mental capabilities or lack of experience and knowledge if they have been given supervision or instruction concerning use of the appliance in a safe way and understand the hazards involved. Children shall not play with the appliance. Cleaning and user maintenance shall not be made by children without supervision.
4. If the supply cord is damaged, it must be replaced by the manufacturer, its service agent or similarly qualified persons in order to avoid a hazard.
5. To avoid a hazard due to instability of the appliance, it must be fixed in accordance with the instructions.
6. When positioning the appliance, ensure the supply cord is not trapped or damaged.
7. Do not locate multiple portable socket-outlets or portable power supplies at the rear of the appliance.
8. Keep ventilation openings, in the appliance enclosure or in the built-in structure, clear of obstruction.
9. Do not use mechanical devices or other means to accelerate the defrosting process, other than those recommended by the manufacturer.
10. Do not use electrical appliances inside the drink storage compartments of the appliance, unless they are of the type recommended by the manufacturer.
11. Do not store explosive substances such as aerosol cans with a flammable propellant in this appliance.
12. Children aged from 3 to 8 years are allowed to load and unload refrigerating appliances.
13. This appliance is intended to be used in household and similar applications such as
  - staff kitchen areas in shops, offices and other working environments;
  - farm houses and by clients in hotels, motels and other residential type environments;
  - bed and breakfast type environments;
  - catering and similar non-retail applications.
14. To avoid contamination of drink, please respect the following instructions:
  - Opening the door for long periods can cause a significant increase of the temperature in the compartments of the appliance.
  - Clean regularly surfaces that can come in contact with drink and accessible drainage systems.
  - Clean water tanks if they have not been used for 48 h, flush the water system connected to a water supply if water has not been drawn for 5 days.
  - If the refrigerating appliance is left empty for long periods, switch off, defrost, clean, dry, and leave the door open to prevent mould developing within the appliance.

Note: This appliance contains flammable foaming agent cyclopentane. Please avoid contact fire when you transport and use it.

Please ask professional for servicing when the machine broke down.

Please send it to your local appointed disposal station when you discard it.

When this appliance is used to the vehicle power :

1.The instructions for appliances having a part of class III construction supplied from a detachable power supply unit shall state that the appliance is only to be used with the power supply unit provided with the appliance.

2.The instructions for class III appliances shall state that it must only be supplied at safety extra low voltage corresponding to the marking on the appliance. This instruction is not necessary for battery-operated appliances if the battery is a primary battery or secondary battery charged outside of the appliance.

When this appliance is used to AC power, please use the adapter to connect the AC power supply.

When this appliance is used to DC power, please connect the vehicle power DC 12V or DC24V.

### Correct disposal of this product



This symbol on the product, or in its packaging, indicates that this product may not be treated as household waste. Instead, it should be taken to the appropriate waste collection point for the recycling of electrical and electronic equipment. By ensuring this product is disposed of correctly, you will help prevent potential negative consequences for the environment and human health, which could otherwise be caused by the inappropriate waste handling of this product. For more detailed information about the recycling of this product, please contact your local council, your household waste disposal service, or the shop where you purchased the product.

## 1, Safety Precautions

Do not touch the power plug when your hands are wet or your feet are in contact with water!

§ When the product is used in a car, if the product is connected to the main power supply, it must be ensured that the power supply has a fuse.

§ To ensure that the product is connected to the correct power supply voltage at all times, the product voltage parameter is on the parameter label at the bottom of the product.

§ Do not place and use electrical products inside the refrigerator container.

§ When the set temperature is less than or equal to 0°C, do not place glass containers to avoid cracking.

§ After unpacking the refrigerator, let it stand for more than 6 hours before powering on.

§ Ensure that the refrigerator is placed horizontally during operation, and the inclination angle is less than 5° for long-term operation.

§ The refrigerator is well ventilated, and blinds are strictly prohibited to dissipate heat. There must be a certain space around the refrigerator. The back of the refrigerator is  $\geq 200\text{mm}$  and the side of the refrigerator is  $\geq 100\text{mm}$ .

§ When water accumulates in the inner tank, do not turn the refrigerator upside down to pour water, just use the drain hole to drain.

§ Appliances that use combustible thermal insulation foaming gas: The R134a refrigerant and cyclopentane foaming materials used in this refrigerator are both combustible materials. The waste refrigerator should be isolated from the fire source and cannot be burned. Please send it to a qualified professional recycling company for disposal. To avoid harm to the environment or cause other dangers.

§ Do not store explosives, such as combustion-supporting sprays, in the box.

§ This product is used for household and similar purposes, such as:

-Kitchen areas in shops, offices or other workplaces;

—— Farm, hotel, motor hotel and residential environment;

-Catering industry and similar non-retail industry applications.

## 2, Product features

Adopting high-efficiency and energy-saving DC compressor and conversion module, high reliability, long service life, fast refrigerator cooling speed

§ Adopt fluorine-free insulation layer, good insulation performance, low energy consumption

§ Dual purpose for car and home, use car DC12/24V or home AC power supply (adapter is required)

§ Rapid ultra-low cooling to -18°C

§ Intelligent protection system for car battery

§ Intelligent energy saving system

§ Partition setting inside the fridge, practical storage method of classification.

§ The door can be opened on three sides with buckle lock device, which is more convenient to operate and use

### 3,Parts List

- § Refrigerator body \*1
- § Manual \*1
- § Cigarette lighter power cord\*1
- § Adapter (optional)

### 4,Control panel operation

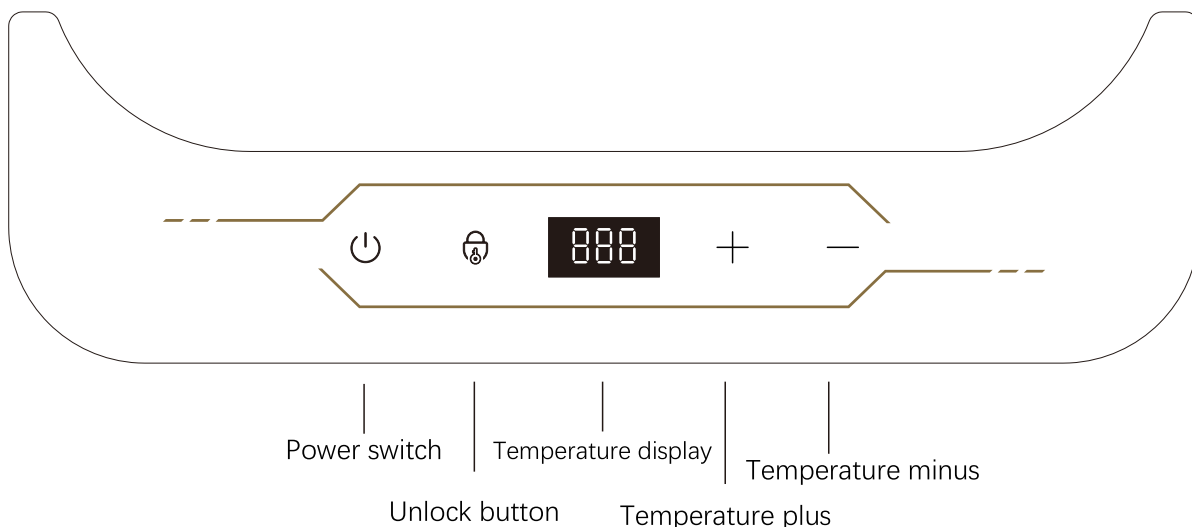

**Power switch:** In the unlocked state, press and hold it for 2 seconds to shut down; when in the locked state, press and hold it for 2 seconds and then turn it on.

**Unlock button:** This button is an anti-misoperation function key, after power on, the refrigerator's all buttons turn to breathing display mode, then all keys can be operated during this time, if there is no operation within 20 seconds, the refrigerator will automatically turn on the anti-misoperation function (or press and hold the unlock button for 2 seconds and then manually turn on the anti-misoperation function), all the keys are locked after turning it on, press the unlock button for 2 seconds to unlock the refrigerator control system and enter the adjustable mode.

**Temperature plus/minus key:** temperature control, adjustable temperature range is -20 ~ 20°C

**Fahrenheit and Celsius temperature display switch:** In the unlocked state, press the temperature plus and minus buttons at the same time for 3 seconds to switch between Fahrenheit and Celsius.

**Battery voltage protection setting:** In the keys unlock state, press and hold the unlock button and the switch key at the same time for more than 2 seconds to enter the battery voltage protection regulation system, select the voltage protection H1/H2/H3, the default voltage protection is H2; enter the mode then press and hold the unlock button and the switch button at the same time for more than 2 seconds to adjust the protection. For detailed voltage protection parameters, see Appendix 1. (This is the car battery voltage protection function; it is set to protect the car battery power under the normal operation of the refrigerator, and prevent the car battery from being consumed too much and the vehicle cannot be started; the output voltage of different vehicle power sources is different, if the voltage protection value "E1" appears on the display, please manually adjust the voltage protection according to the actual situation of the vehicle.)

Protection	12V shut-down value	12V boot value	12V shut-down value	12V boot value
H1	9.6V	10.9V	21.3V	22.7V
H2	10.1V	11.4V	22.3V	22.7V
H3	11.1V	<b>12.4V</b>	24.3V	25.7V

## 5,Recommended storage temperature for common items

Type	Recommended temperature
Red wine	10C°
Insulin	2C°-8C°
Fruit	4C°-6C°
Beverage	2C°-5C°
Meat	-10C°
Ice cream	-15C°

## 6,Common problem and failure display instructions

### 1)The refrigerator does not work

- § Check whether there is a power supply or the voltage is correct;
- § Check whether the power plug is in good contact;
- § Whether the fuse is blown;
- § Check whether the power switch on the display operation panel is turned on;
- § The compressor is under protection after 3 minutes of startup;

### 2)The food in the refrigerator is frozen

- § The temperature setting is too low, increase the temperature appropriately.

### 3)Hear the sound of running water in the box

- § The sound of refrigerant flowing is normal.

### 4)Display error code and processing method

- § When the compressor control module displays the fault code, the refrigerator will not work until the fault is eliminated.The specific fault code corresponding to the troubleshooting method is described as follows.

Failure codes:

Flash numbers	Failure type	Remarks
1	Voltage failure	The input voltage is outside the setting range
2	Fan current failure	The fan output current is too large
3	Compressor start failed	Compressor motor is blocked or the system pressure is too high
4	Compressor minimum speed failure	Compressor load is too large or the motor speed is too small
5	Control temperature failure	Controller cover temperature is too high
6	Control hardware failure	The controller detects abnormal parameters

## 7. Electric Diagram

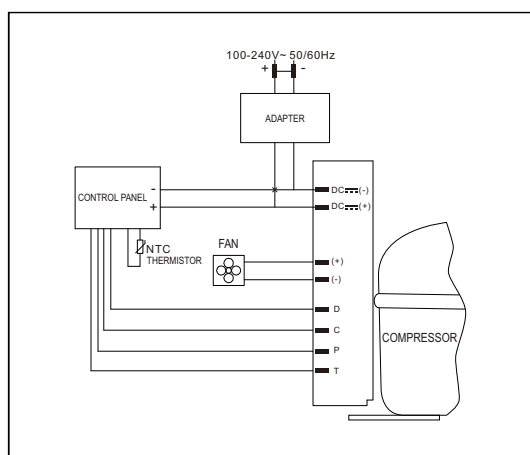

used for AC power supply

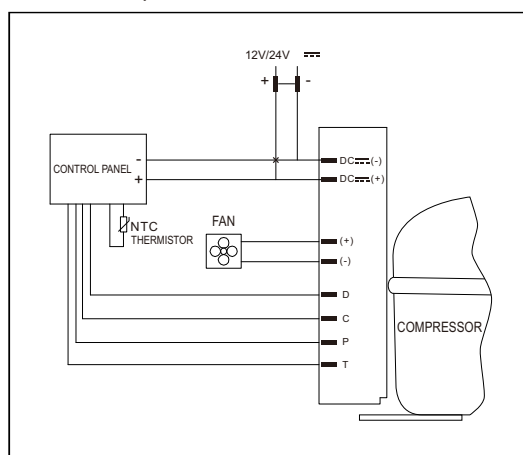

used for DC power



## 8. Technical Specification

Product model	CB30S
Dimension	600x337x390
Capacity(L)	30
Net Weight(KG)	13.8
Gross Weight(KG)	15.8
Climate Class	T/ST/N/SN
Temperature control	Electronic
Rated voltage(V)	100-240V~
Frequency(Hz)	50/60Hz
RATED CURRENT FOR AC(ADAPTOR)	2.5A
RATED VOLTAGE DC	12V/24V 
RATED CURRENT FOR DC	6.0A(12V)/3.0A(24V)
Refrigerant(g)	R1234YF(28g)
PROTECTIVE CLASSIFICATION OF ELECTRIC SHOCK RESISTANCE	 / 