

HALLE

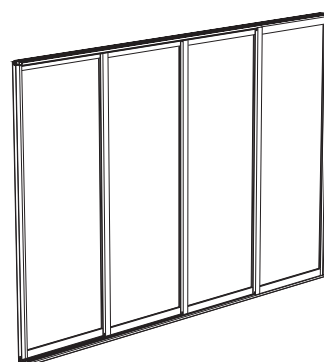
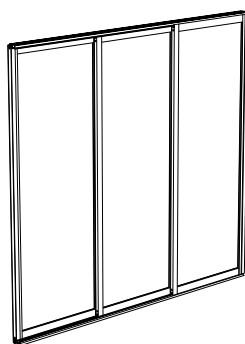
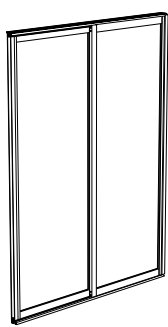
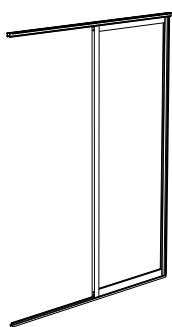
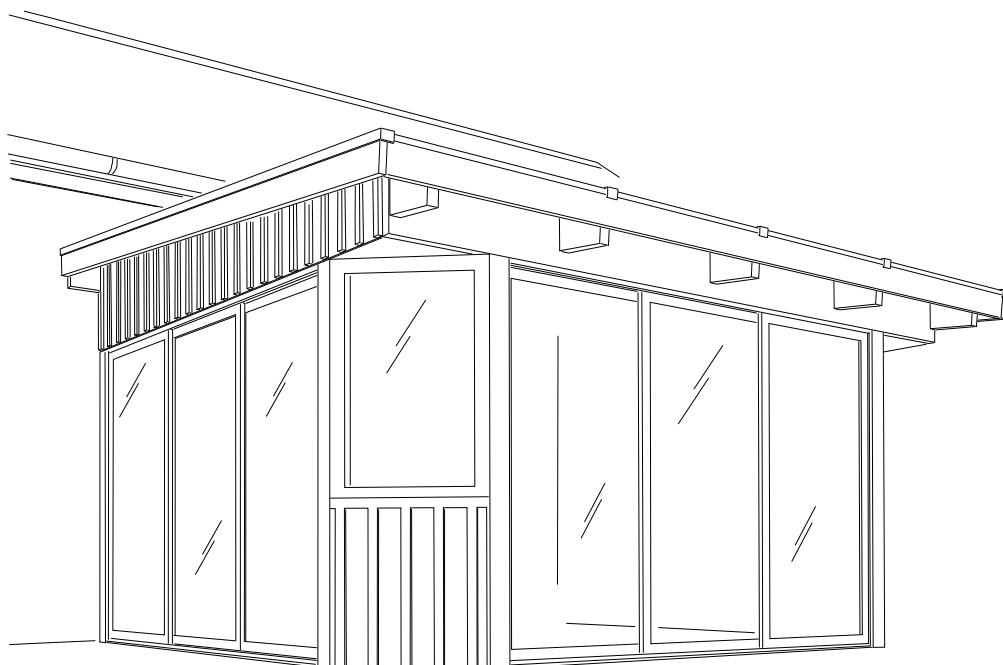

Primo

1d - 2d - 3d - 4d

Skjutbar

Primo

Skjutbar

1d - 2d - 3d - 4d

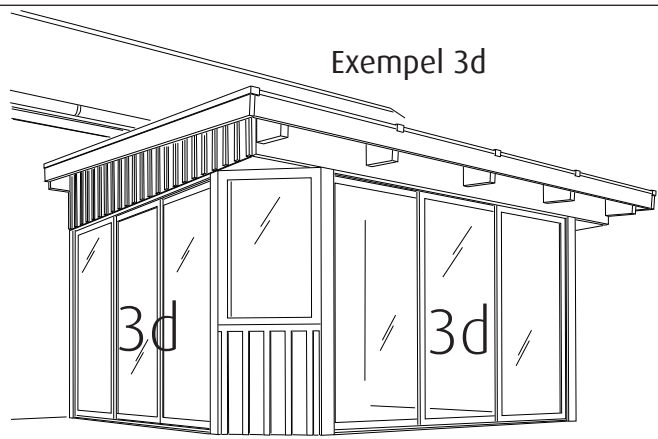

Skjutbara partier höjd 1990mm

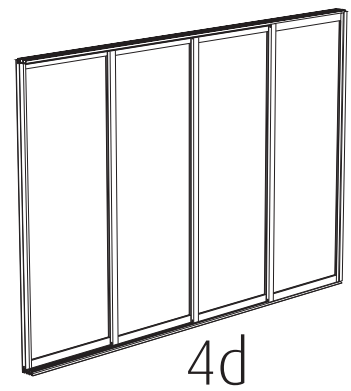
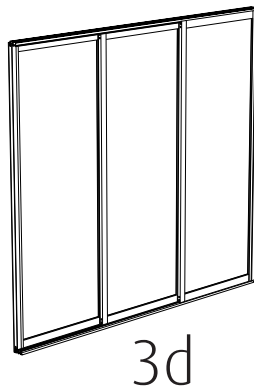
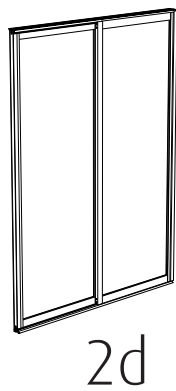
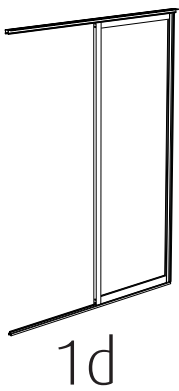

Skjutbara fönsterpartier höjd 1190mm

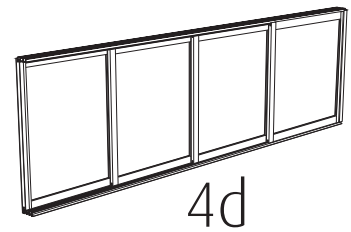
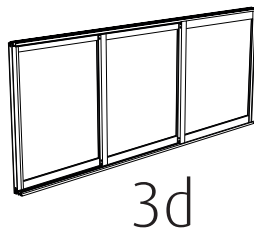
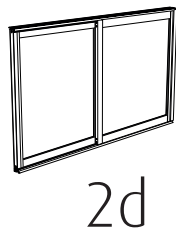
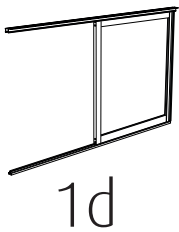

Skena övre & undre

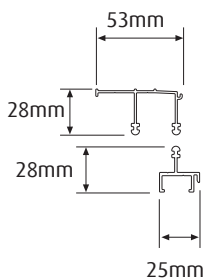

1d = 1-spår skena

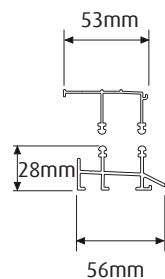

2d = 2-spår skena

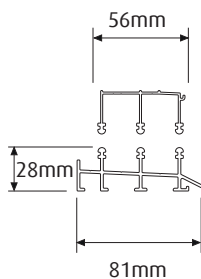

3d = 3-spår skena

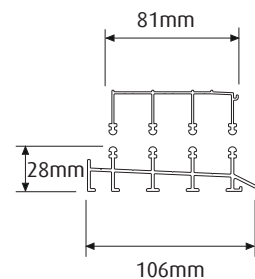

4d = 4-spår skena

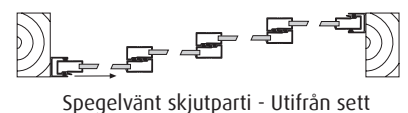
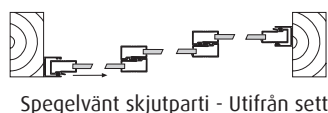
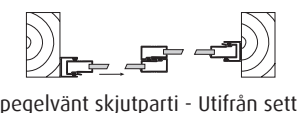
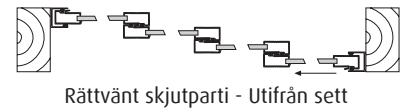
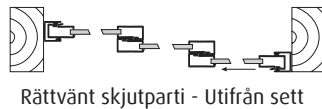
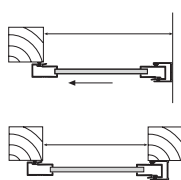

Läs igenom instruktionen innan ni börjar

Read through the instructions before you begin!

HALLE

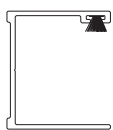

x2 Sidoprofil



Gummipackning skruv

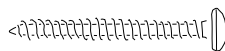

4,2x45mm

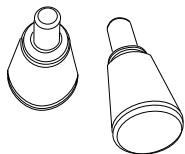

Låsknopp

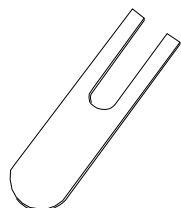

Stödplatta



Täckplugg dörr



Dörrstopp

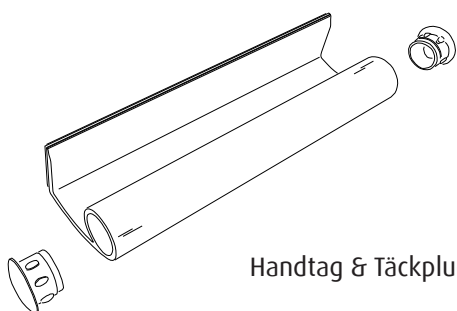

Handtag & Täckplugg

Verktyg som kan behövas / Tools that may be needed

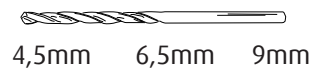
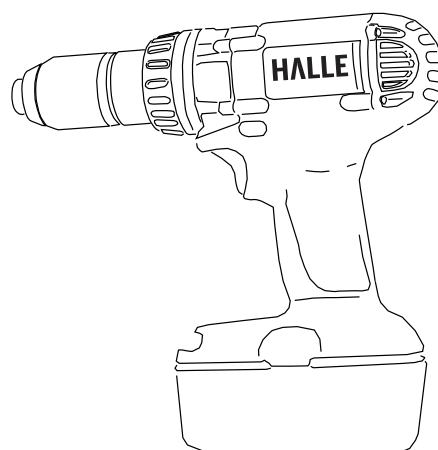
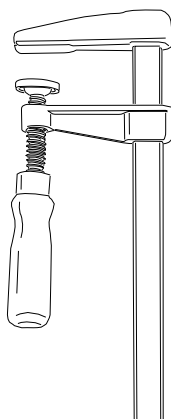
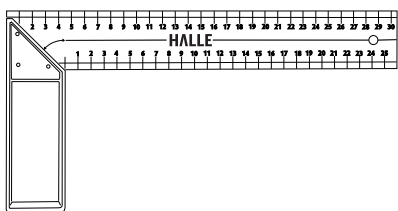

4,5mm 6,5mm 9mm



Torx

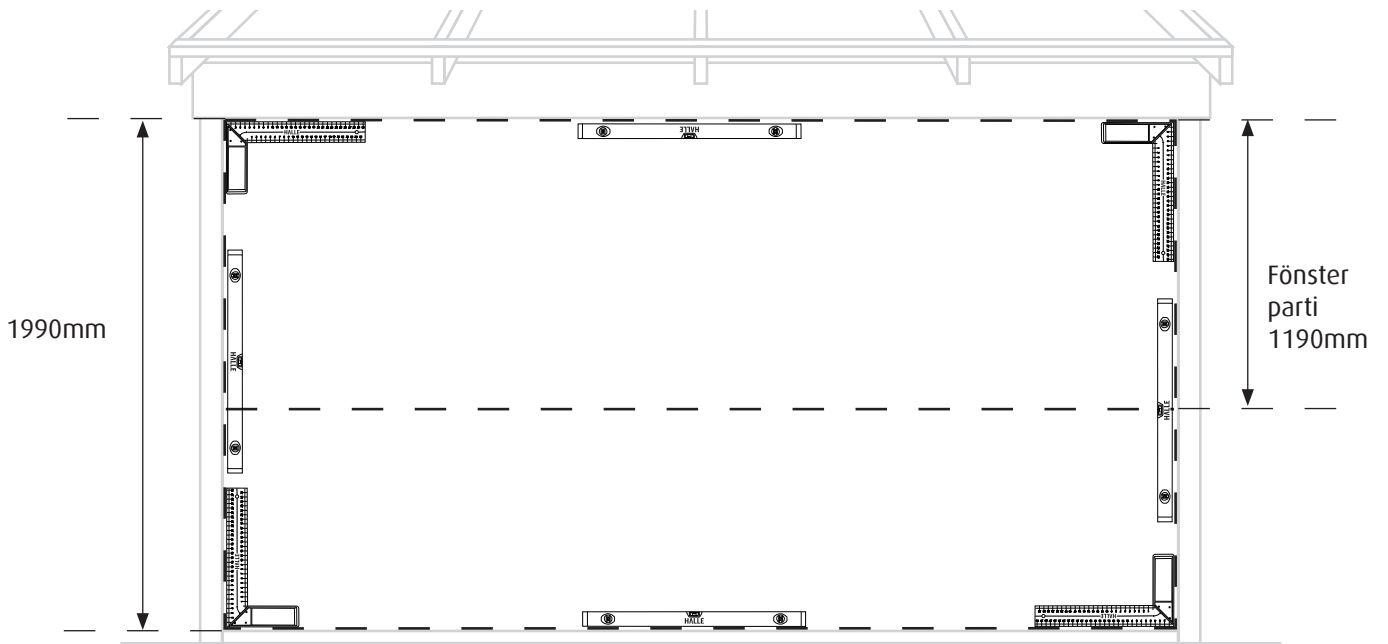
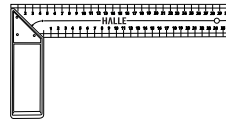
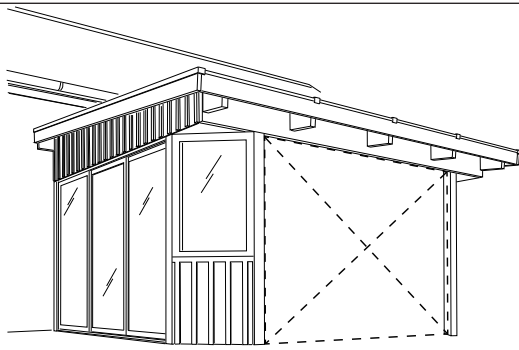

Exempel: Rättvânt - Spegelvânt

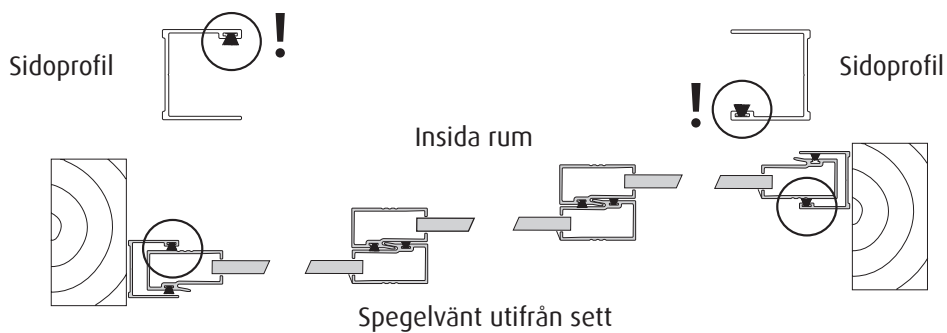
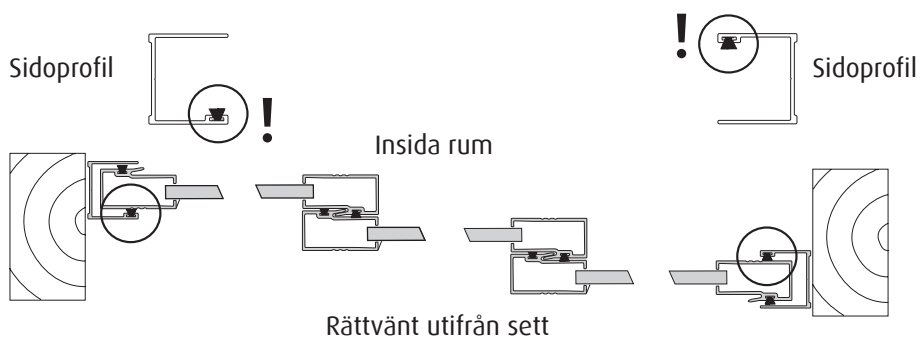

1

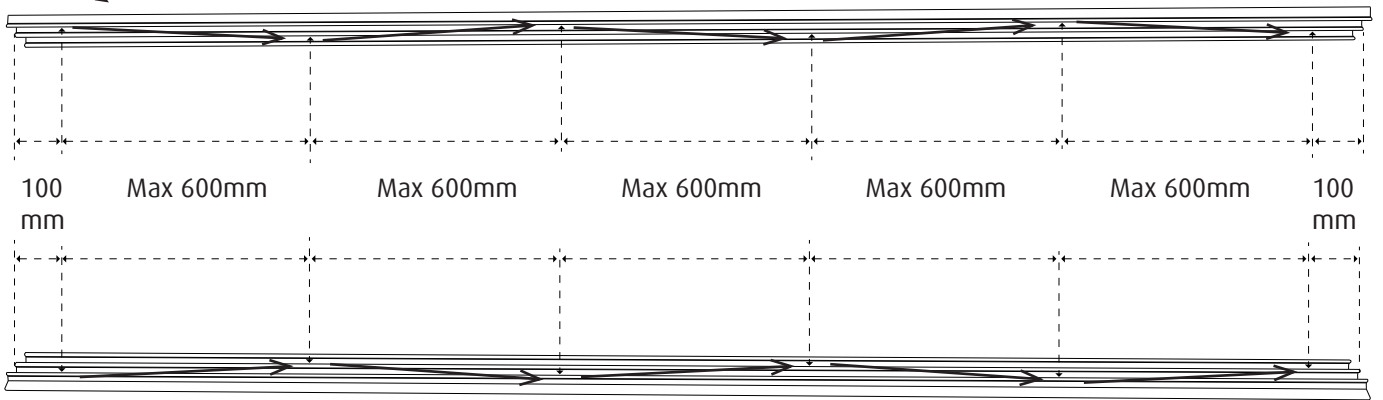
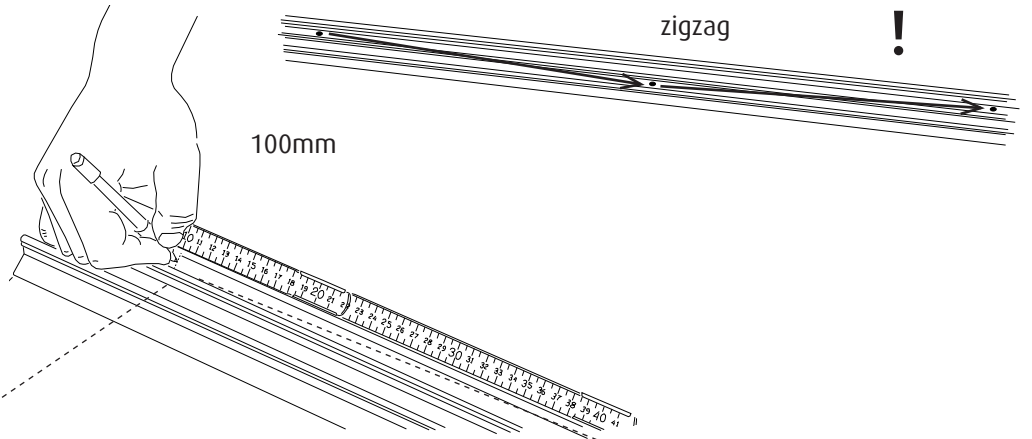

2

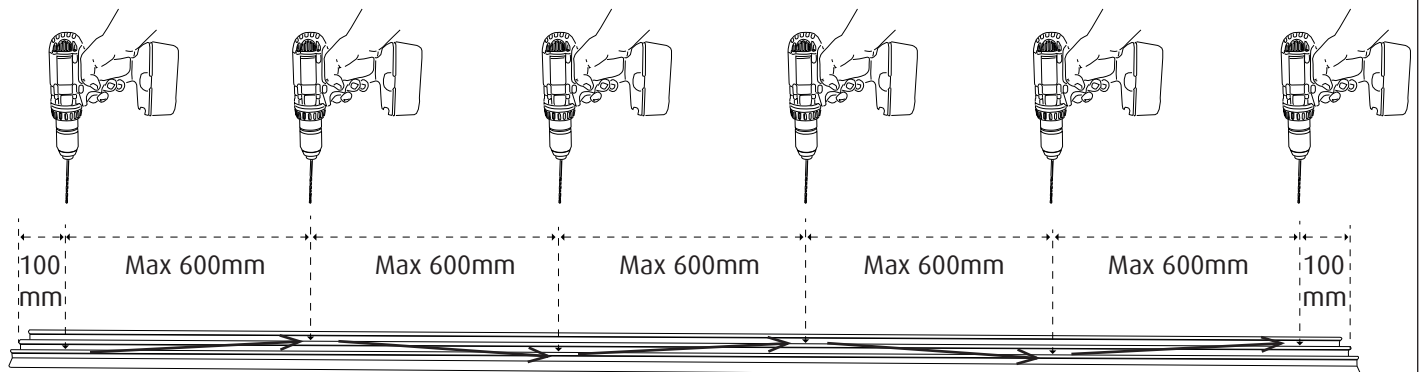
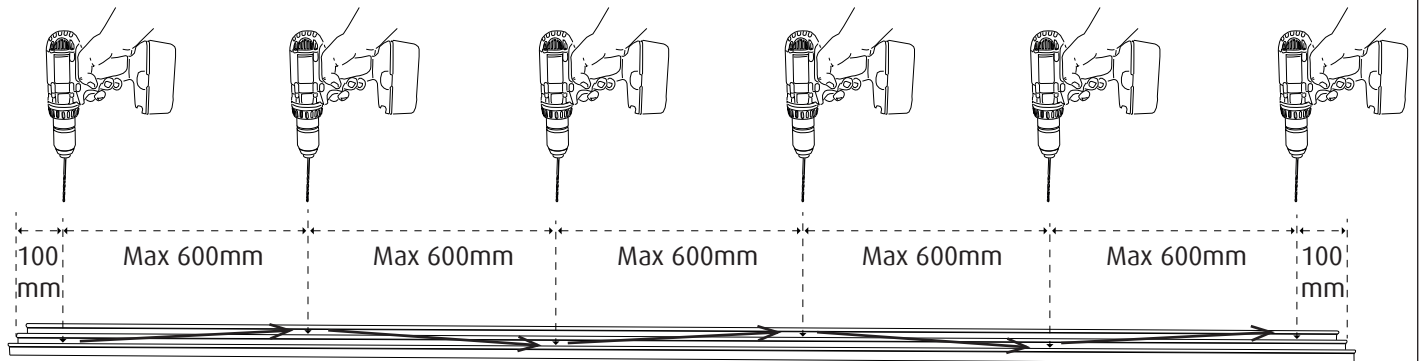

3 Skena undre

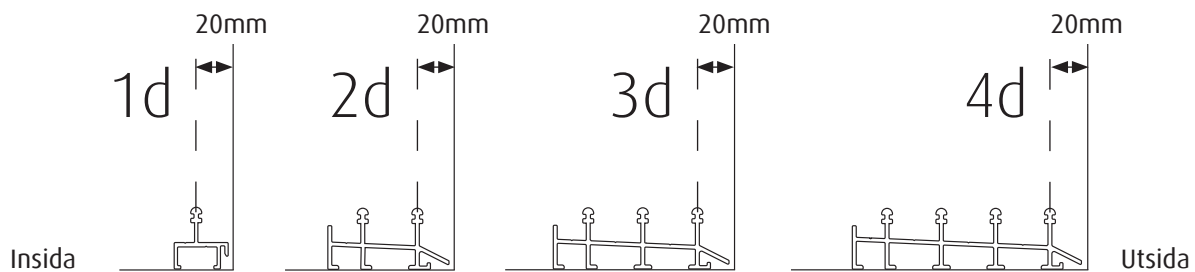
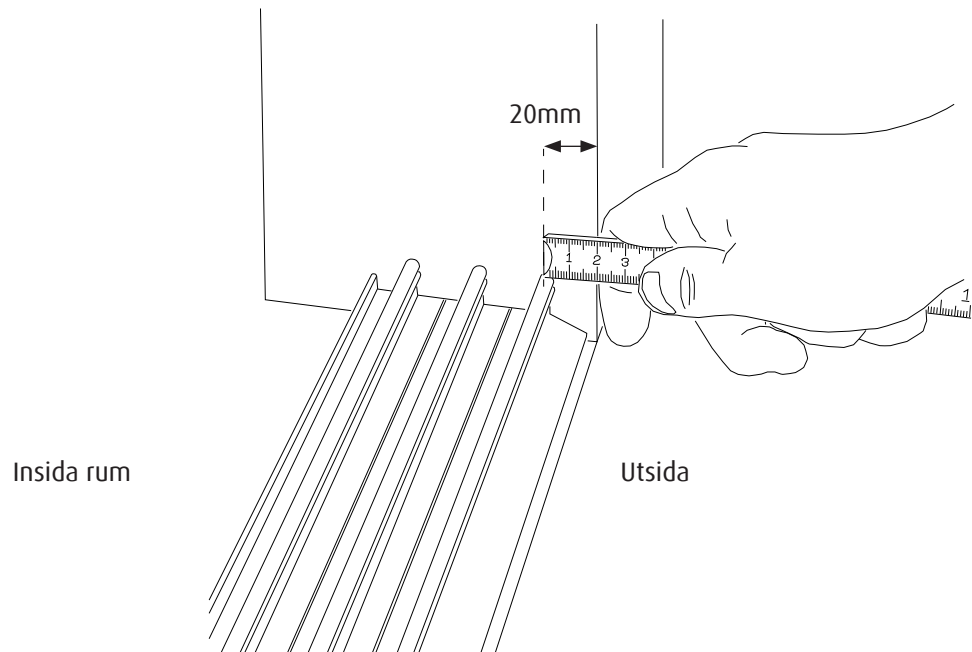

4 Skena övre

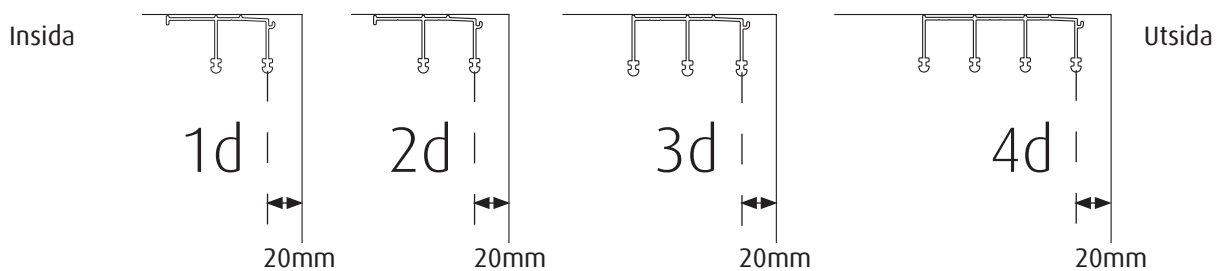
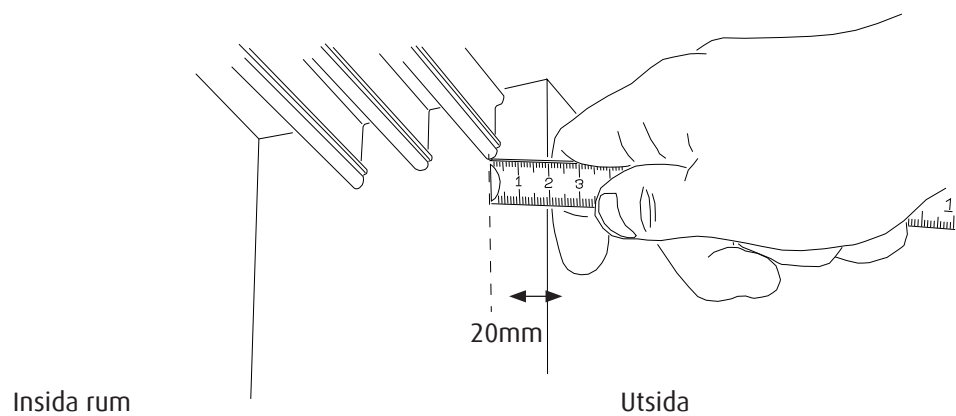

5

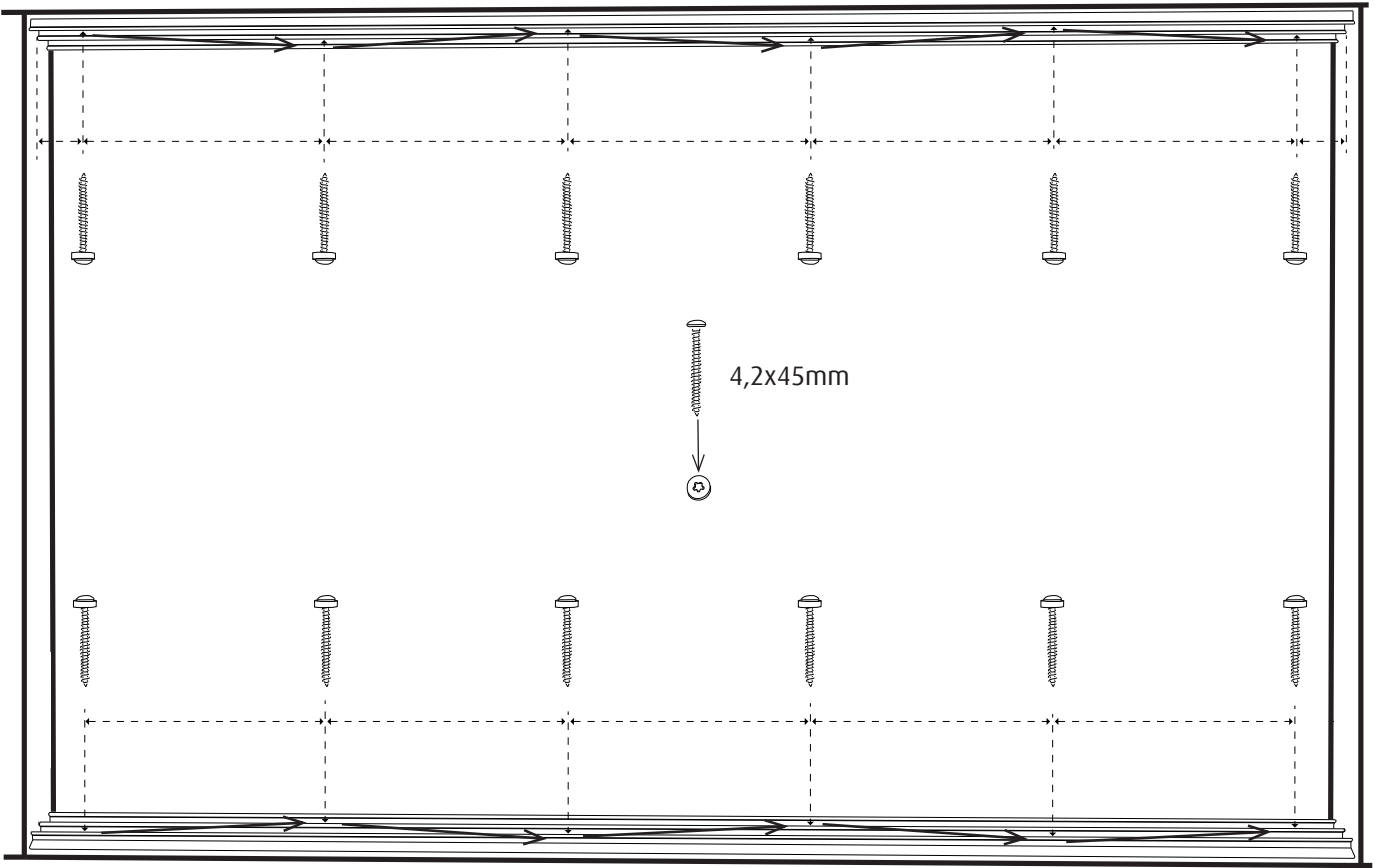

6

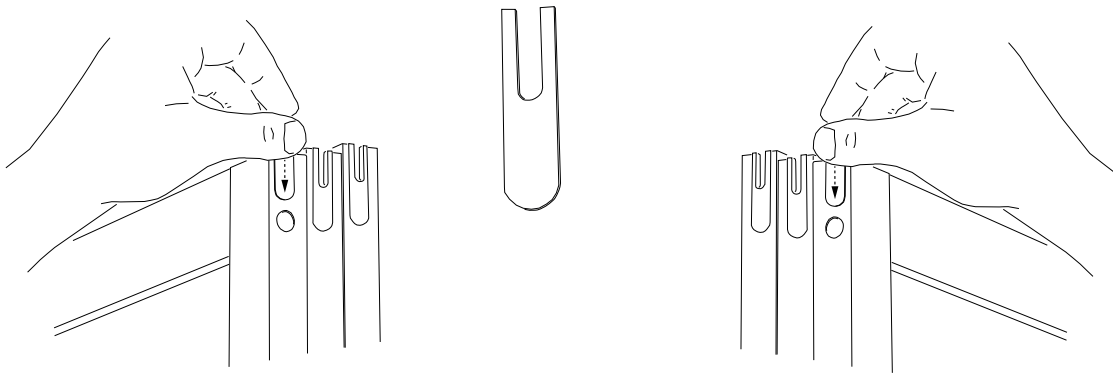

7

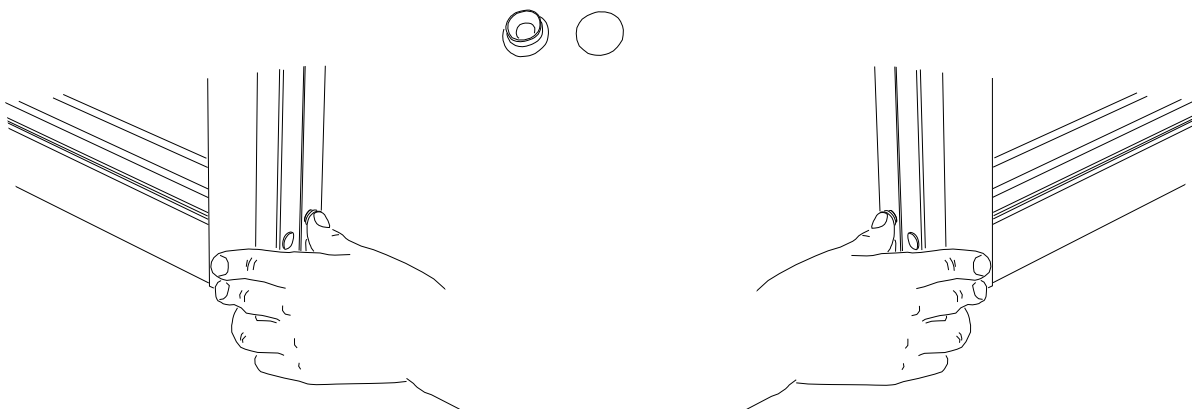

8

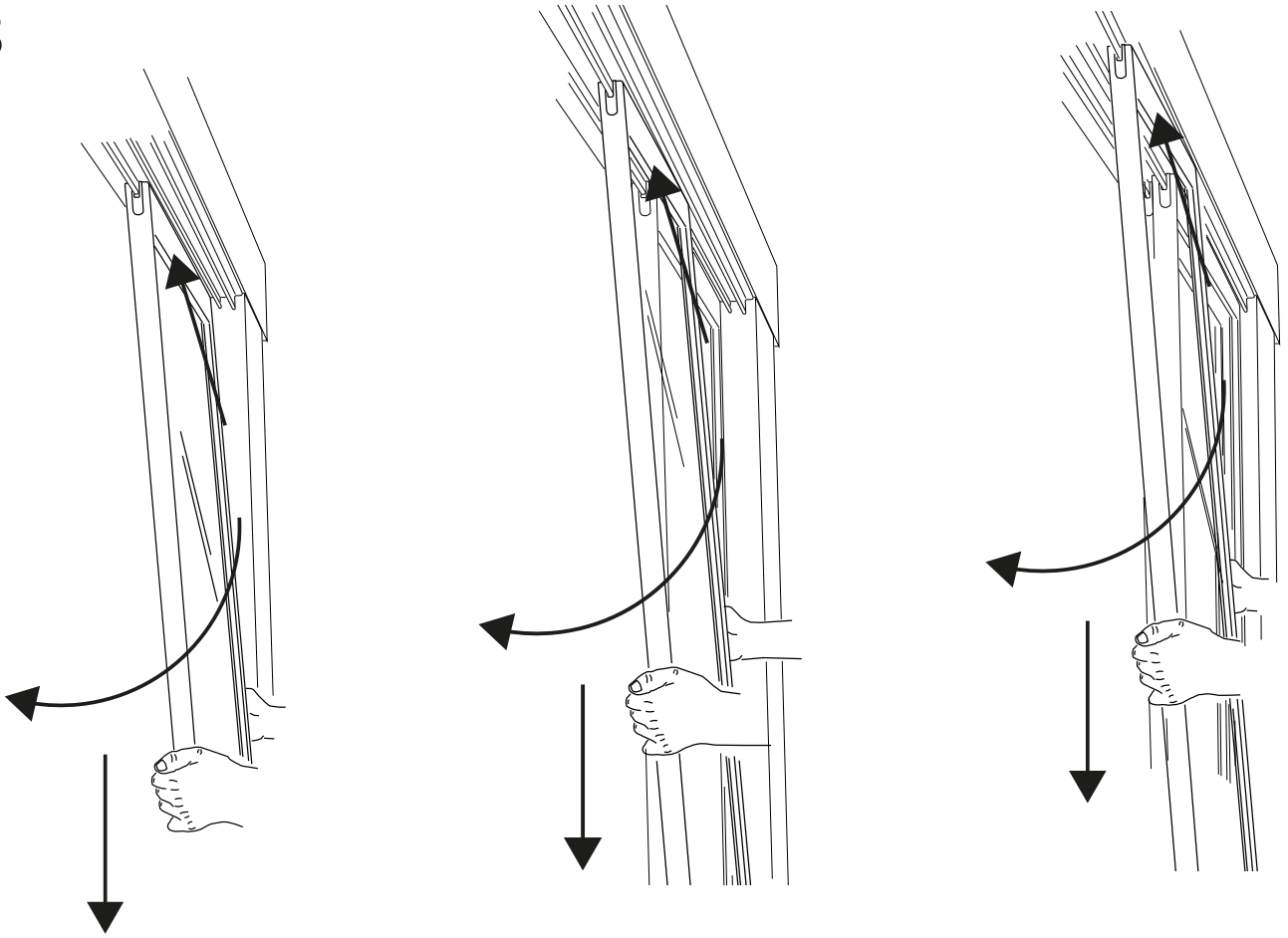

9

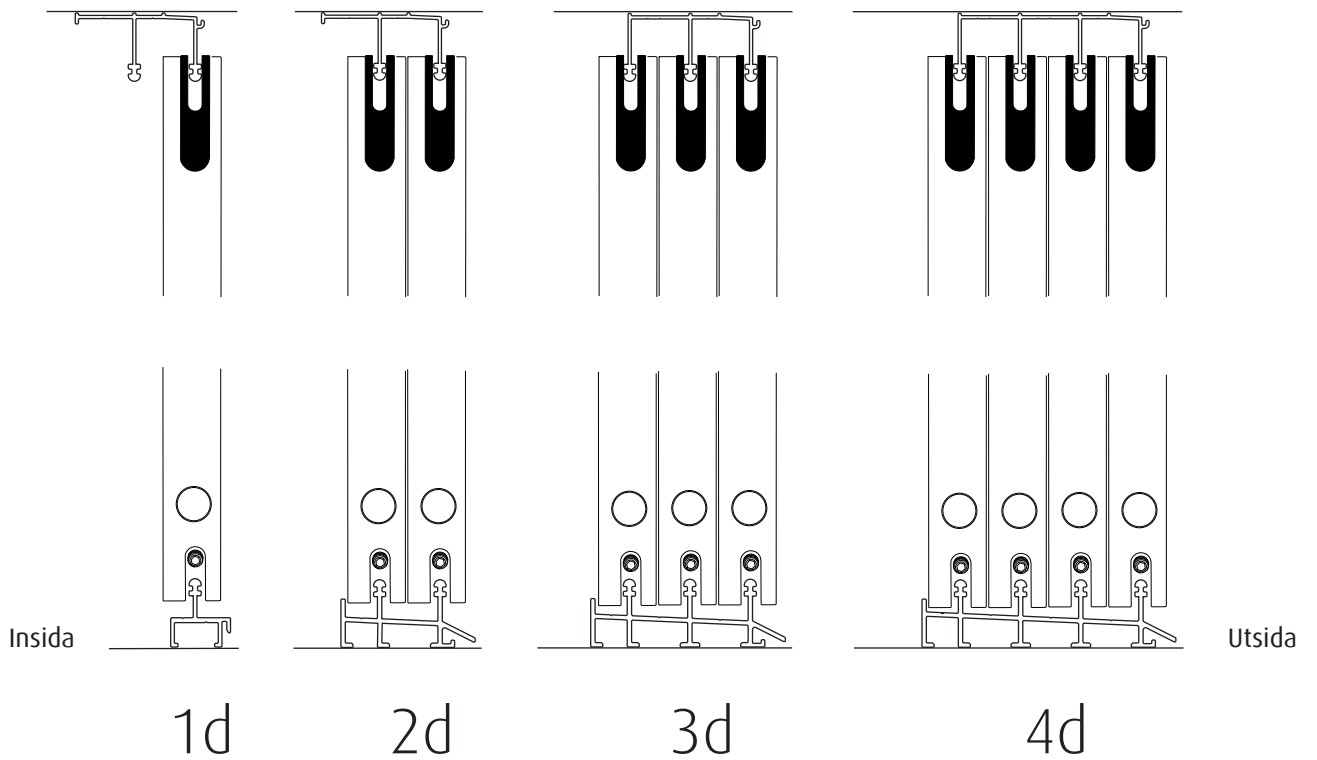

10

Justera hjul.

Partier försedda med hjul är justerade från fabrik, det är därför viktigt att skenorna är vågrätt monterade, ibland kan viss hjuljustering behövas på både höger och vänster sida framifrån sett för att partierna skall bli i lod.

- * Vrid medurs = dörren höjs på den sida man justerar
- * Vrid moturs = dörren sänks på den sida man justerar

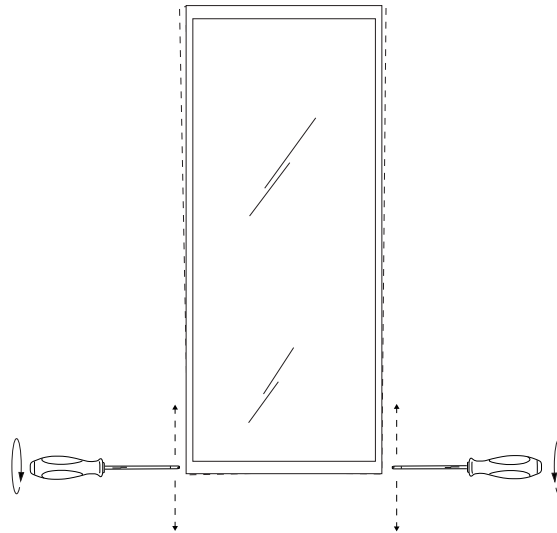
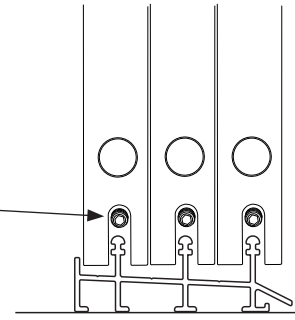
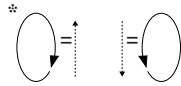

11

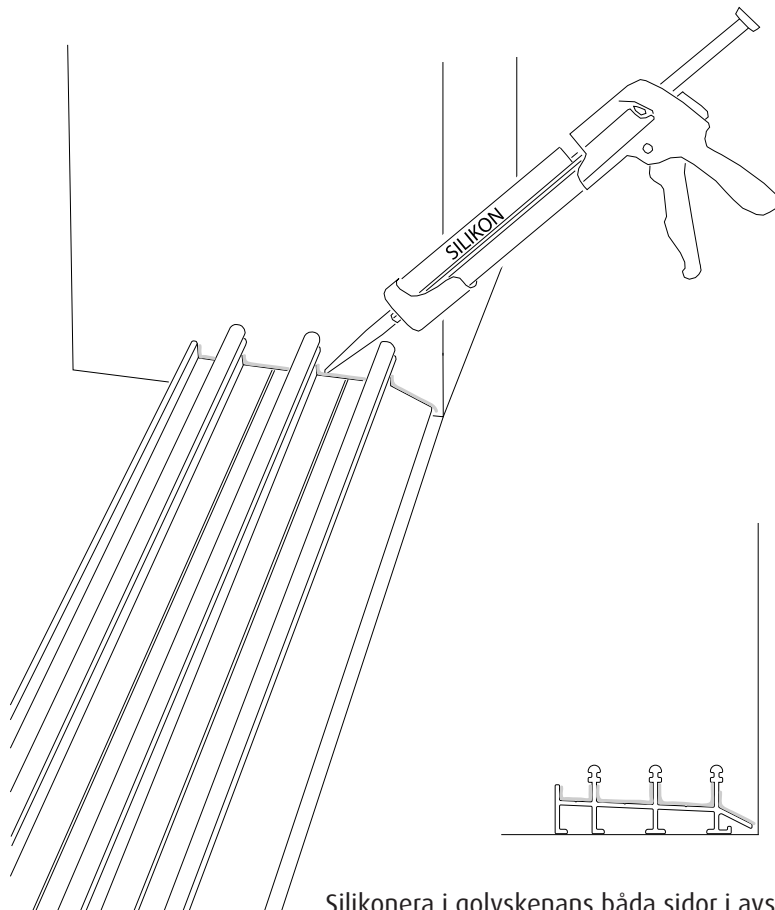

Silikonera i golvskenans båda sidor i avslutningen mot träpelare

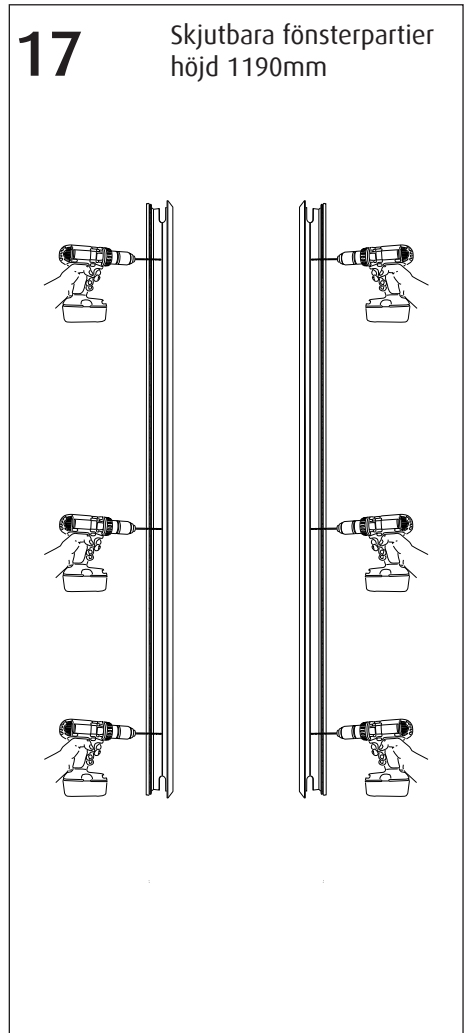
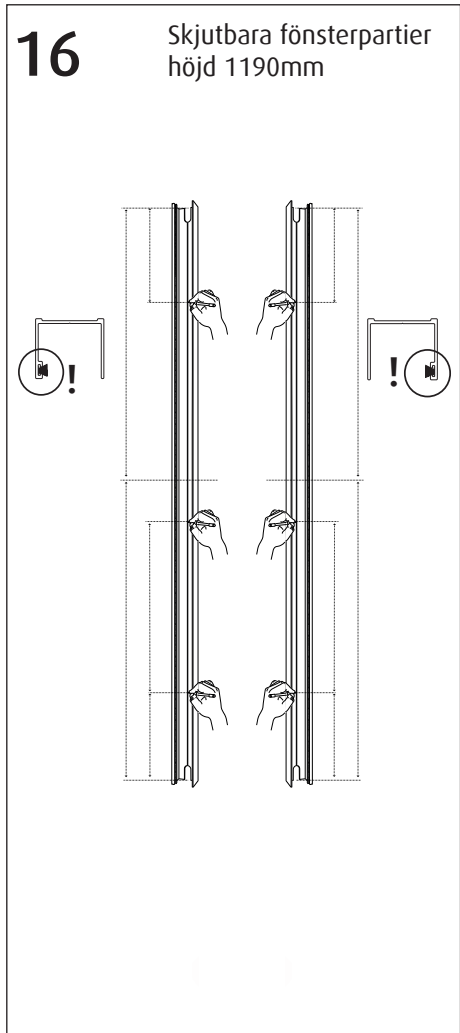
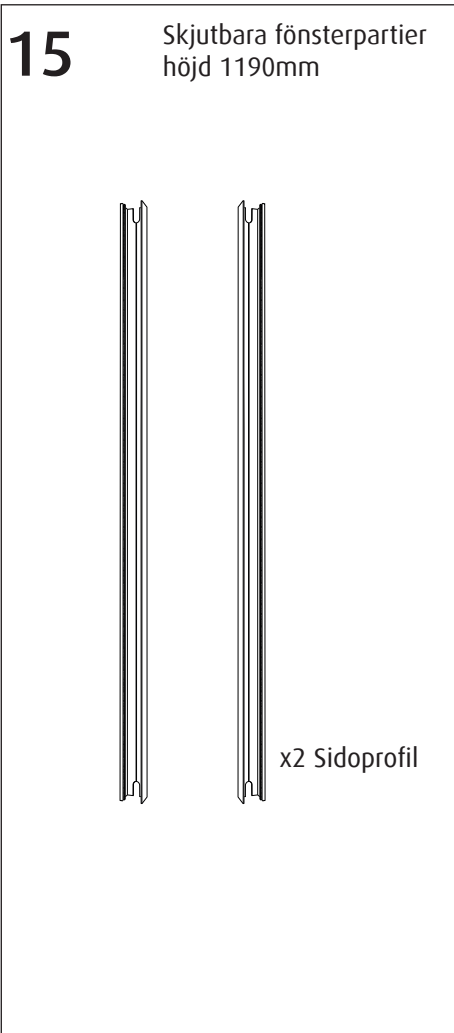
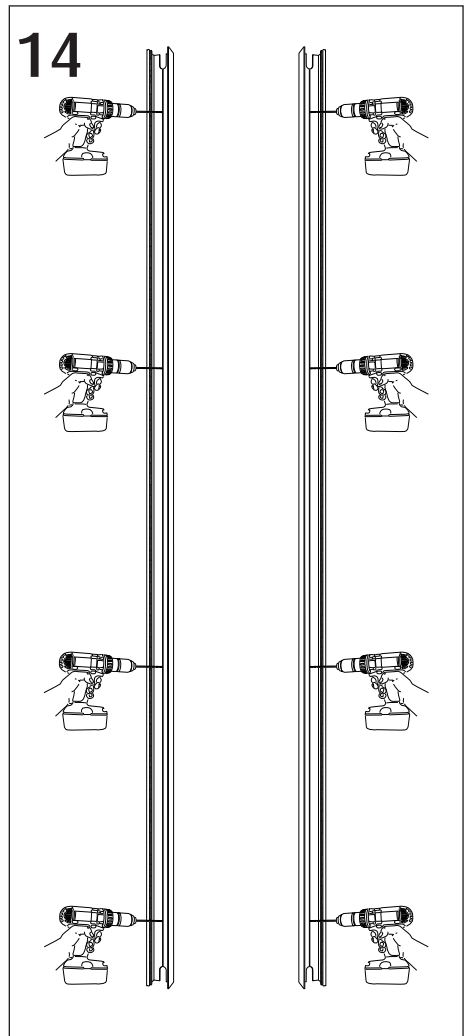
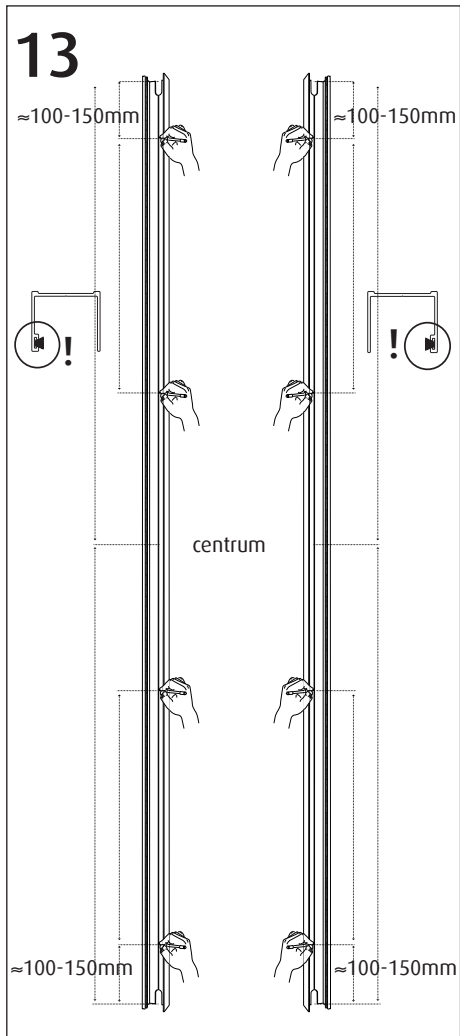
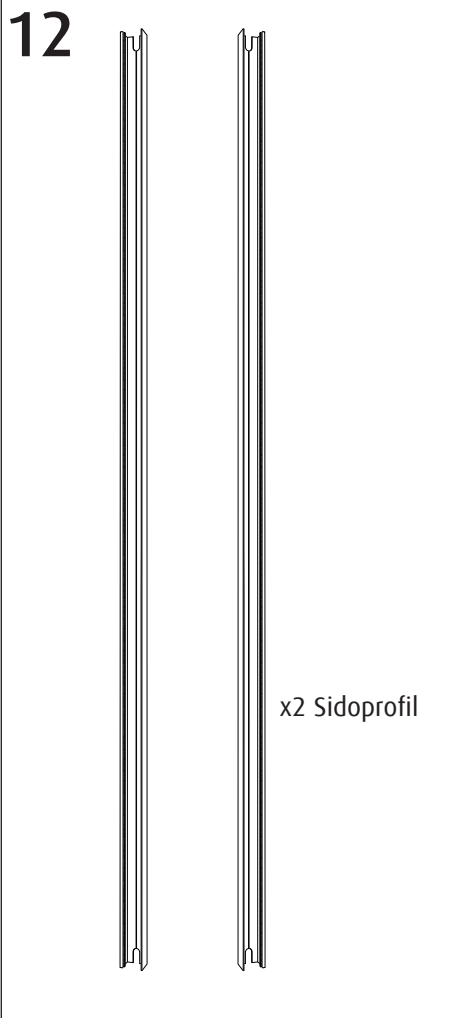

18

*Exempel Rättvänt

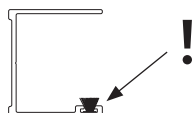
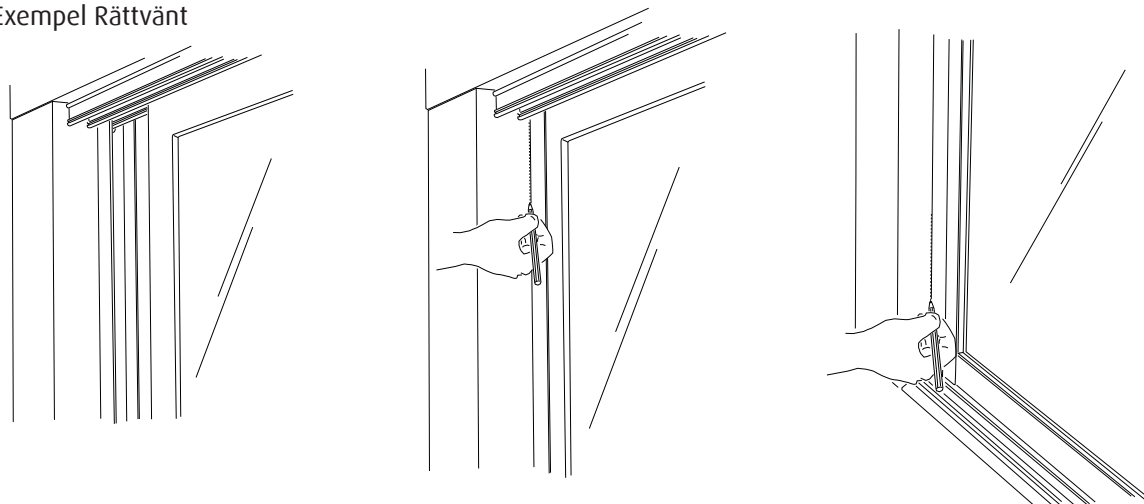

Sidoprofil

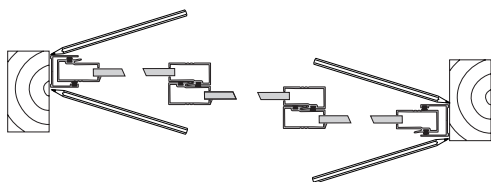

*Rättvänt utifrån sett

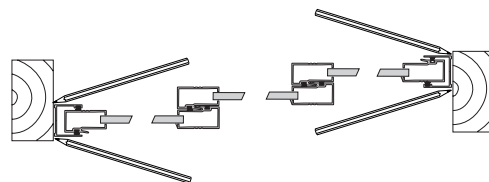

Speglvänt utifrån sett

19

*Exempel Rättvänt

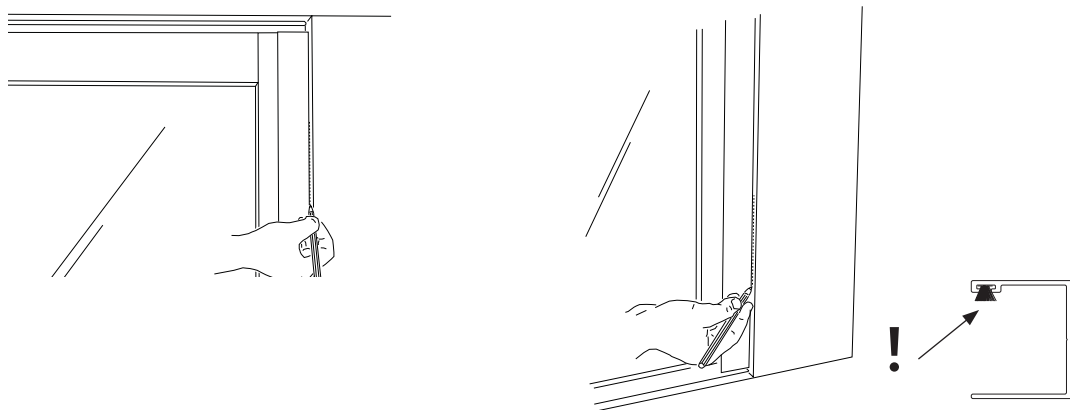

Sidoprofil

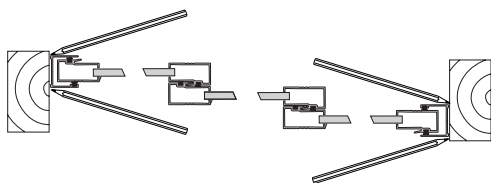

*Rättvänt utifrån sett

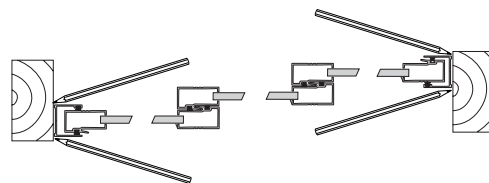

Speglvänt utifrån sett

20

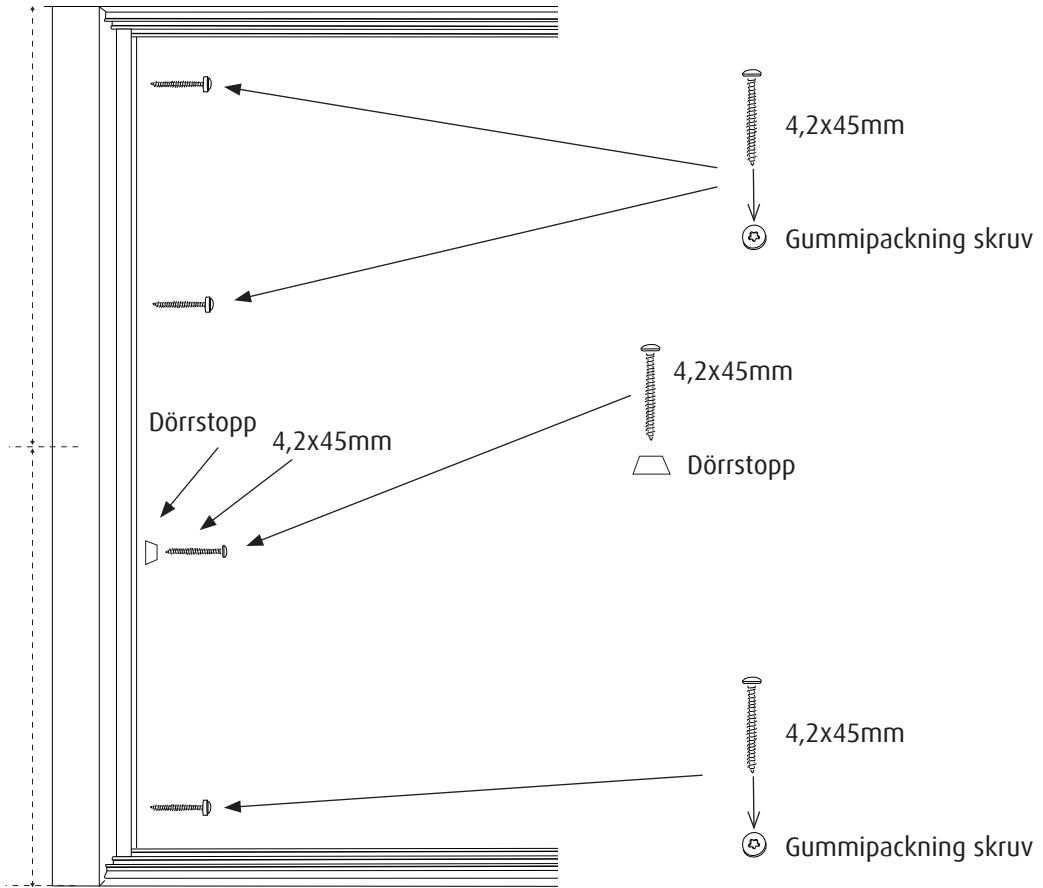

21

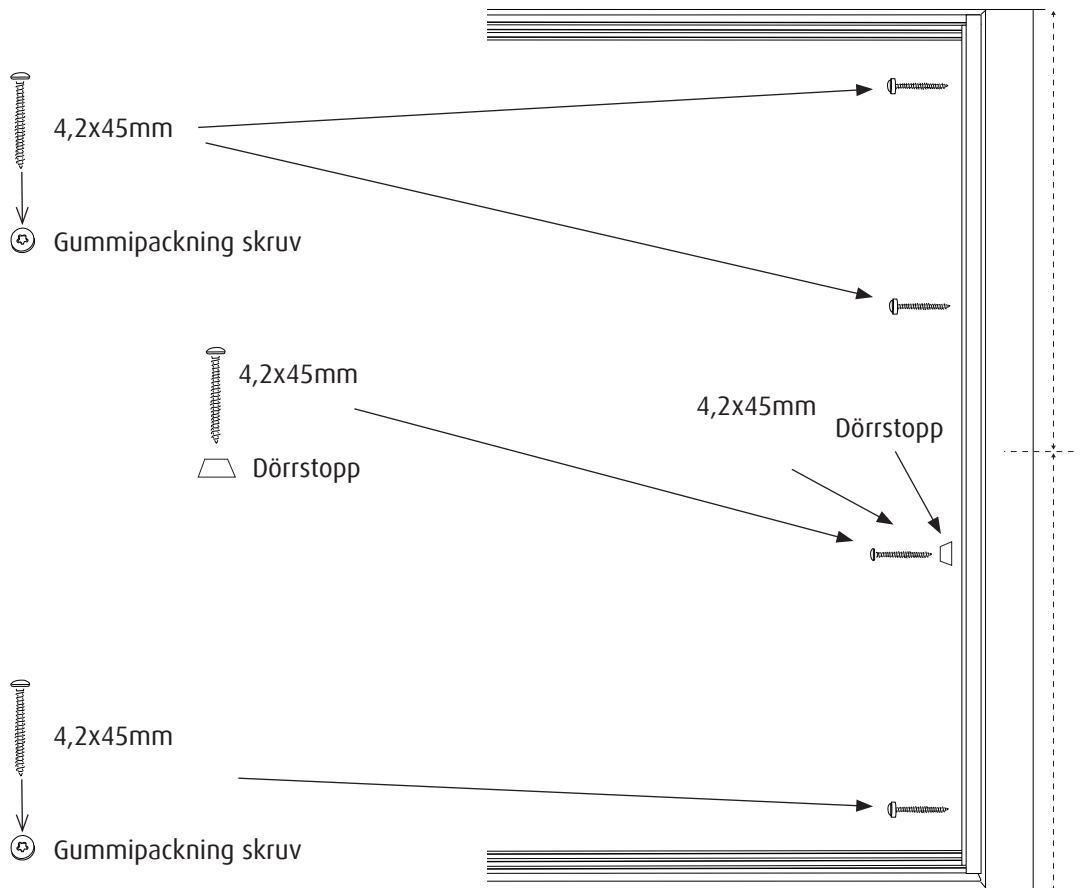

22

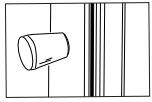

Montering av låsknopp

* Borra EJ igenom hela profilerna med borr 6,5mm, endast sidprofil och luckans första del, se teckning nedan!

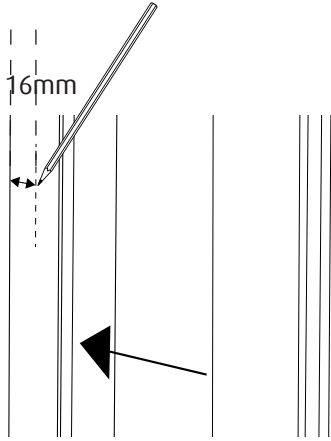

Insida

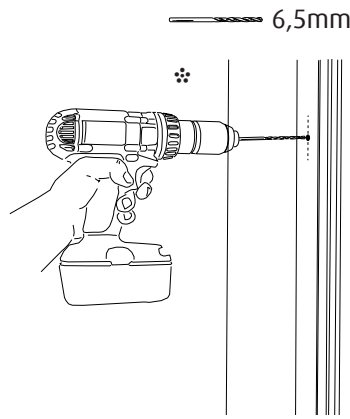

Insida

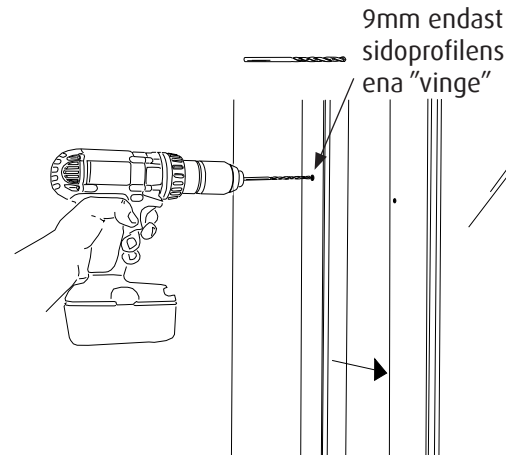

Insida

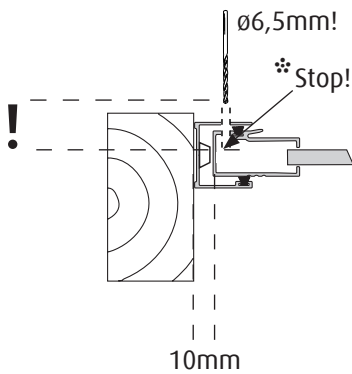

Insida

* Borra EJ igenom hela profilerna med borr 6,5mm, endast sidprofil och luckans första del, se teckning!

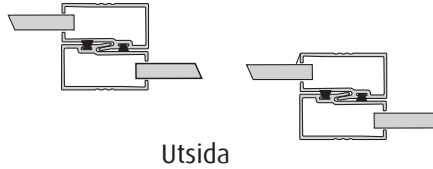

Utsida

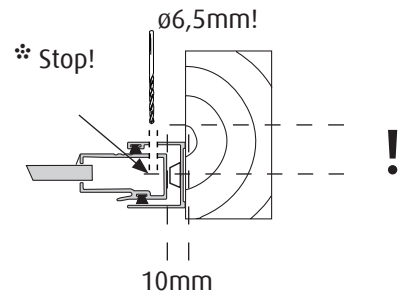

23

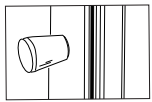

Montering av låsknopp

* Borra EJ igenom hela profilerna med borr 6,5mm, endast sidprofil och luckans första del, se teckning nedan!

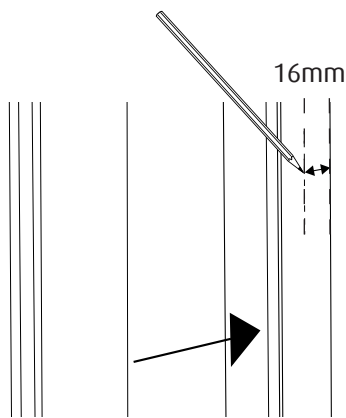

Insida

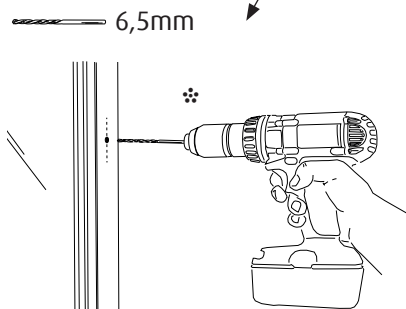

Insida

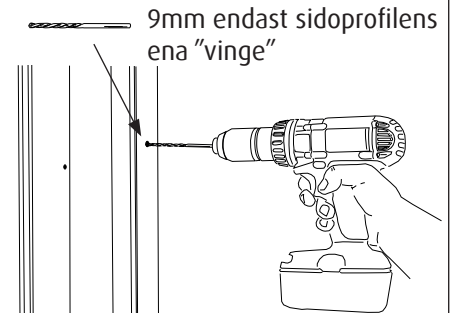

Insida

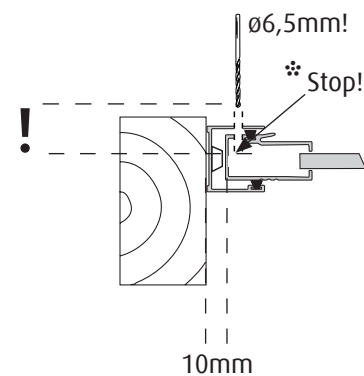

Insida

* Borra EJ igenom hela profilerna med borr 6,5mm, endast sidprofil och luckans första del, se teckning!

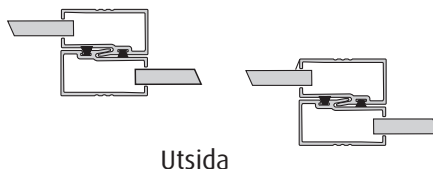

Utsida

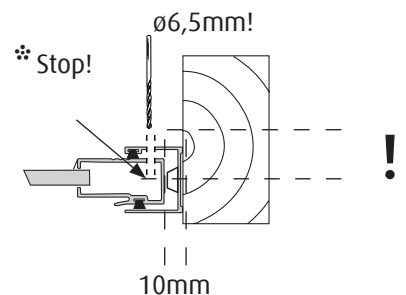

24 Montering av låsknopp

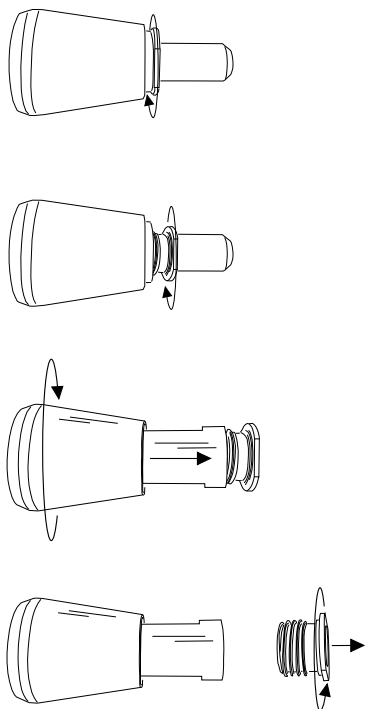

25 Montering av låsknopp

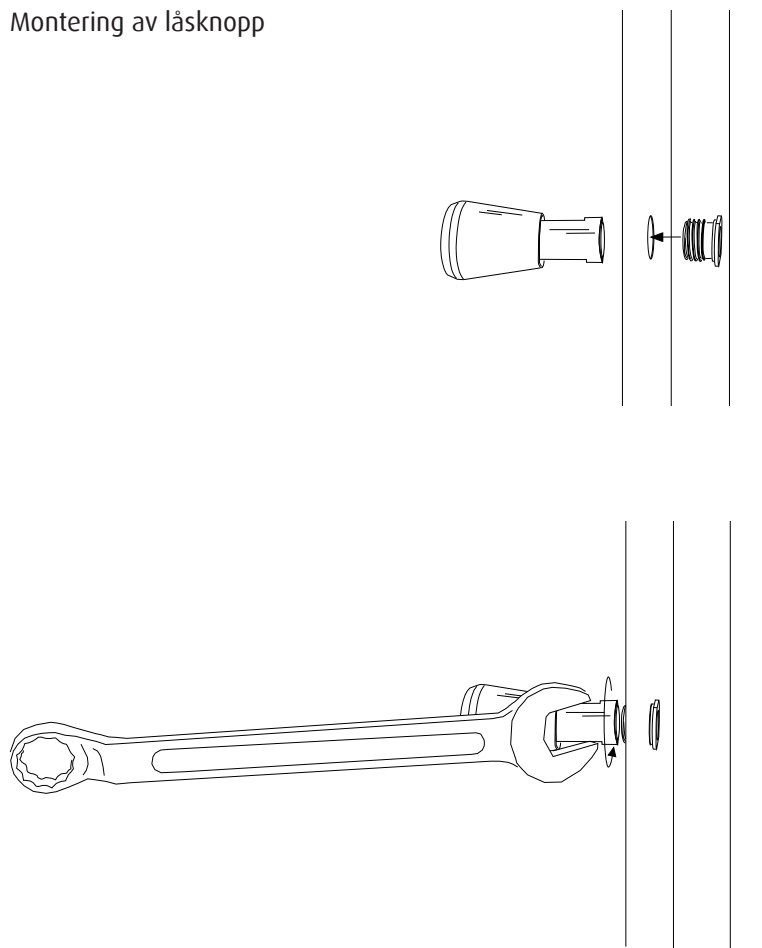

26 Montering av låsknopp

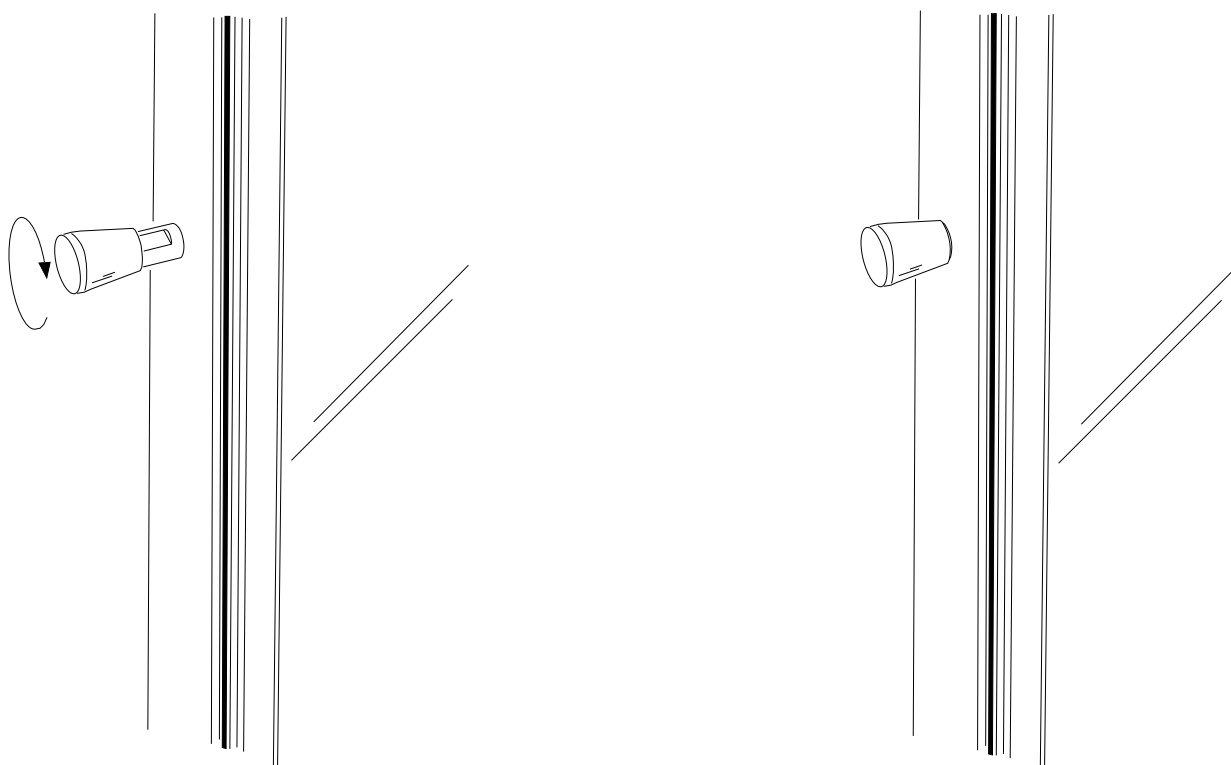

27

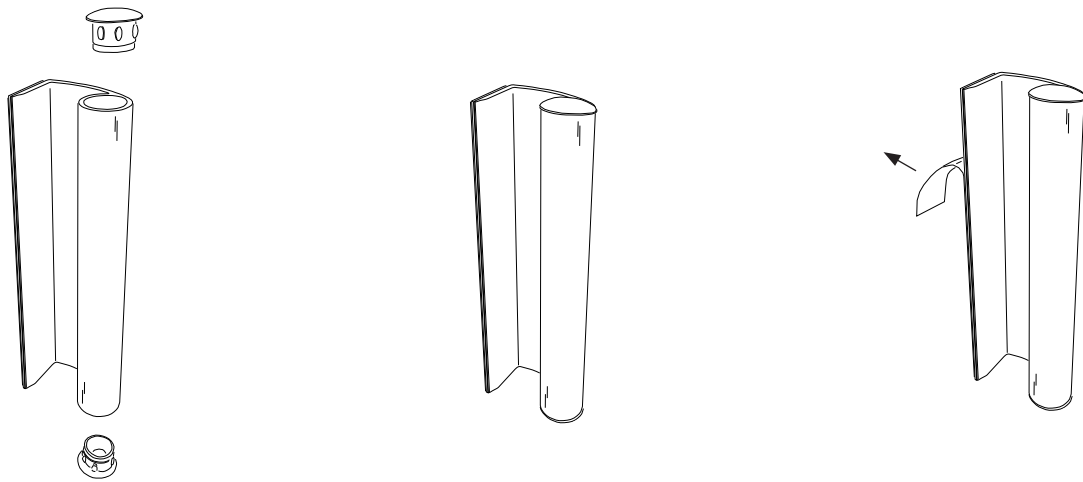

28

Rengör aluminiumprofilens yta med t.ex. T-Röd innan handtaget sätts fast.

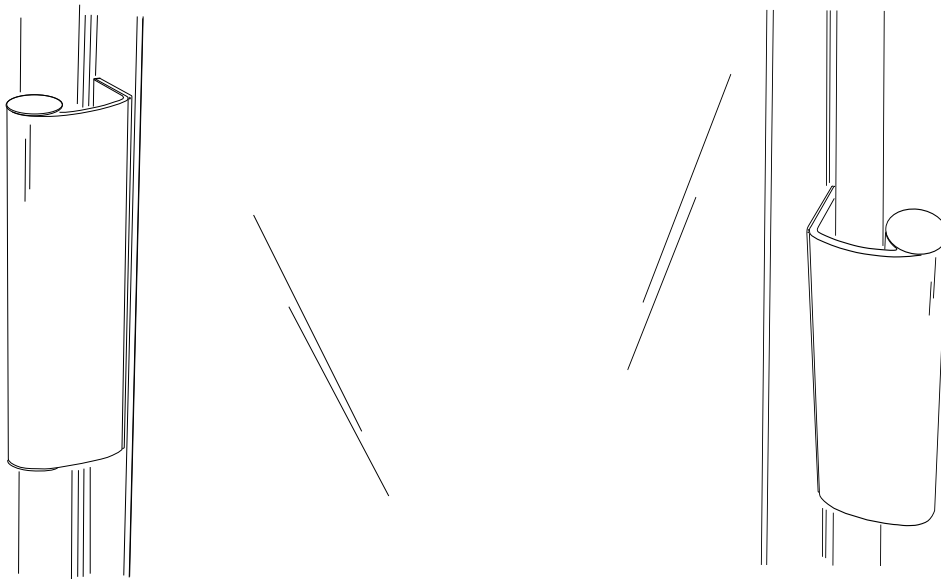

HALLE

Halle
Profilgatan 1
312 34 Laholm
www.halle.se